

#1  
SELLING  
BASEBALL  
FRANCHISE

# The Deepest Baseball Simulation Available Just Got Deeper for 2003!

## LOOK FOR

The most realistic player animations

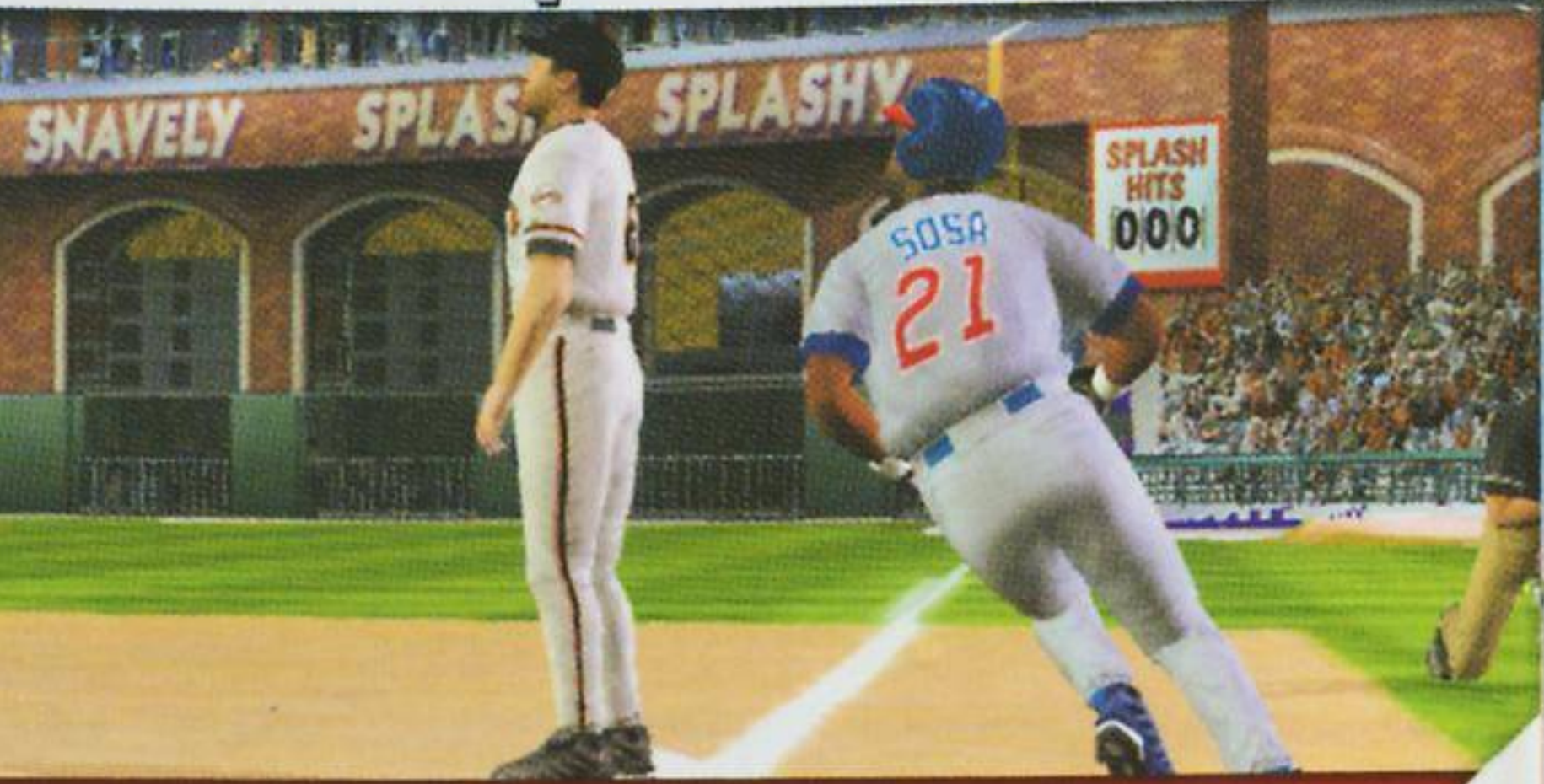

Improved Fielding, Throwing & Baserunning

Over 50 playable teams

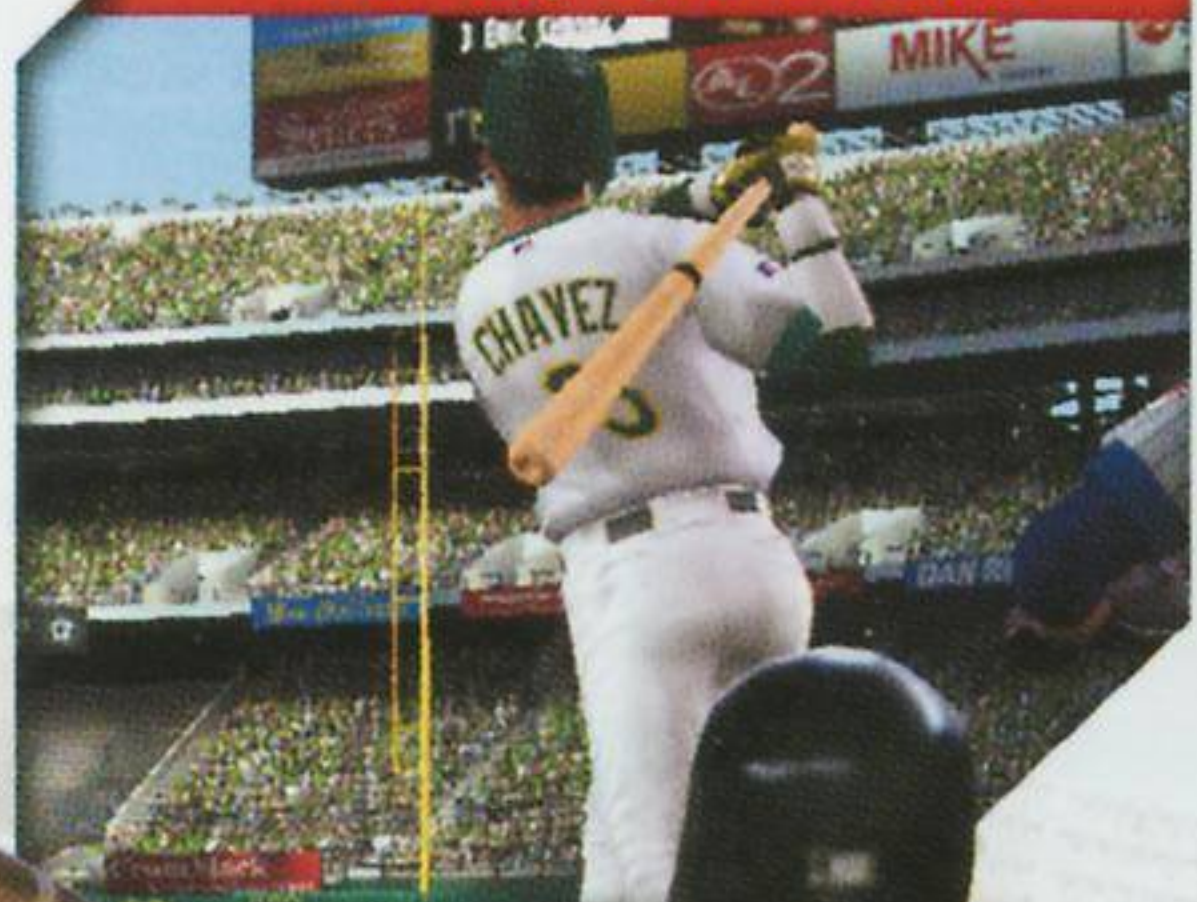

DOWNLOAD  
NEW CONTENT ON  
LIVE™

75 stadiums, 200 uniforms and 20 unlockable teams

- More than 80 new features and improvements, including:
  - Complete front end overhaul
  - In-game save capability
- 9 new gameplay modes, including:
  - Scenario Mode
  - Pick-up Game Mode
  - Deeper, more customizable Franchise Mode
- Over 110 retired Legends of MLB and Negro Leagues – including Babe Ruth, Lou Gehrig, Ty Cobb, Cal Ripken, Satchel Paige, Josh Gibson and Buck O'Neil.

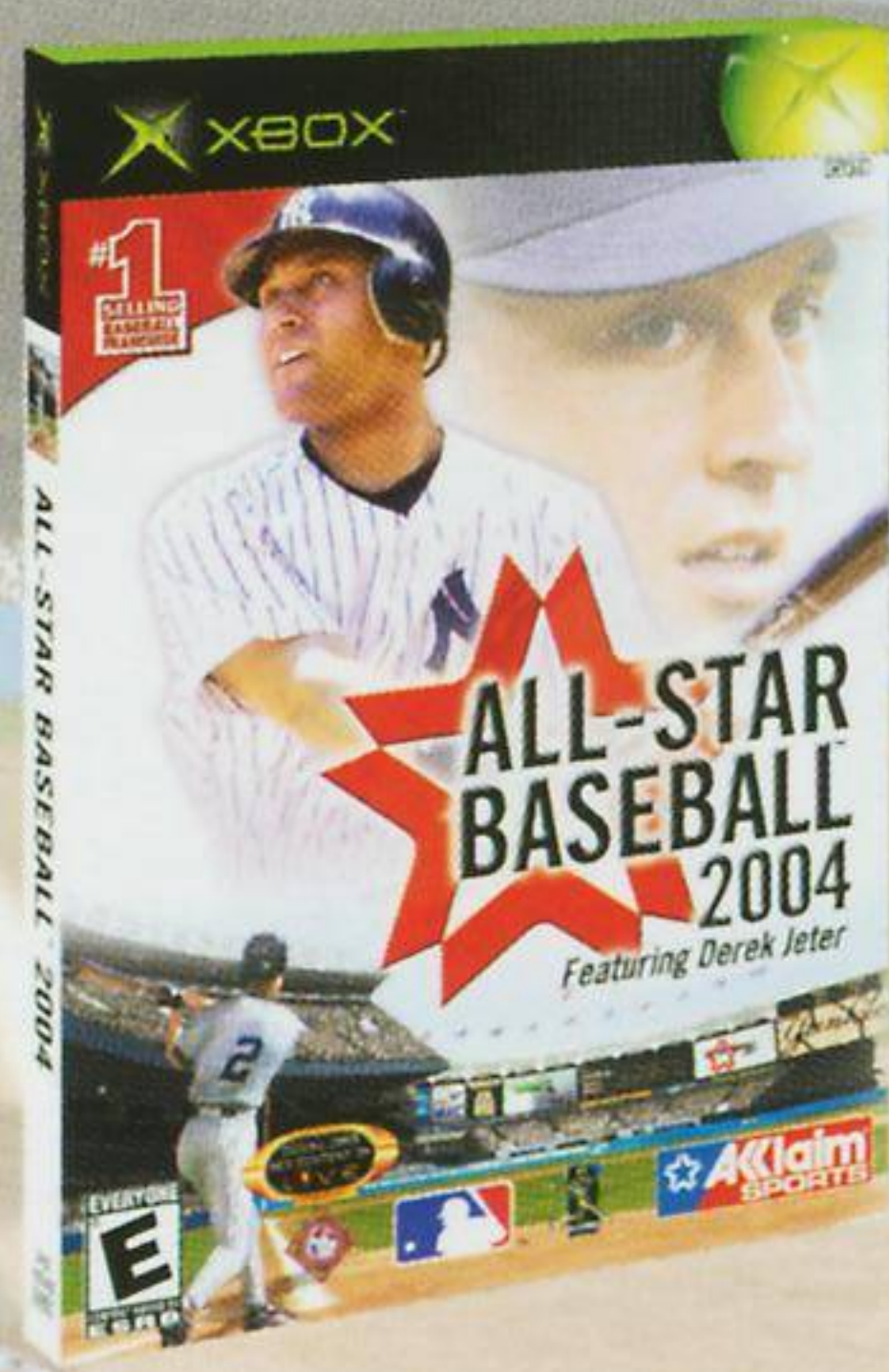

## ALL-STAR BASEBALL™ 2004

Featuring Derek Jeter



Acclaim Entertainment, Inc., One Acclaim Plaza, Glen Cove, NY 11542-2777.

Burnout™ 2 Point of Impact © 1998-2003 Criterion Software Limited. All Rights Reserved. Burnout is a Trademark of Criterion Software Limited. Acclaim © & © 2003 Acclaim Entertainment, Inc. All Rights Reserved. Developed by Criterion Games. All Rights Reserved.



# BURNOUT™ POINT OF IMPACT

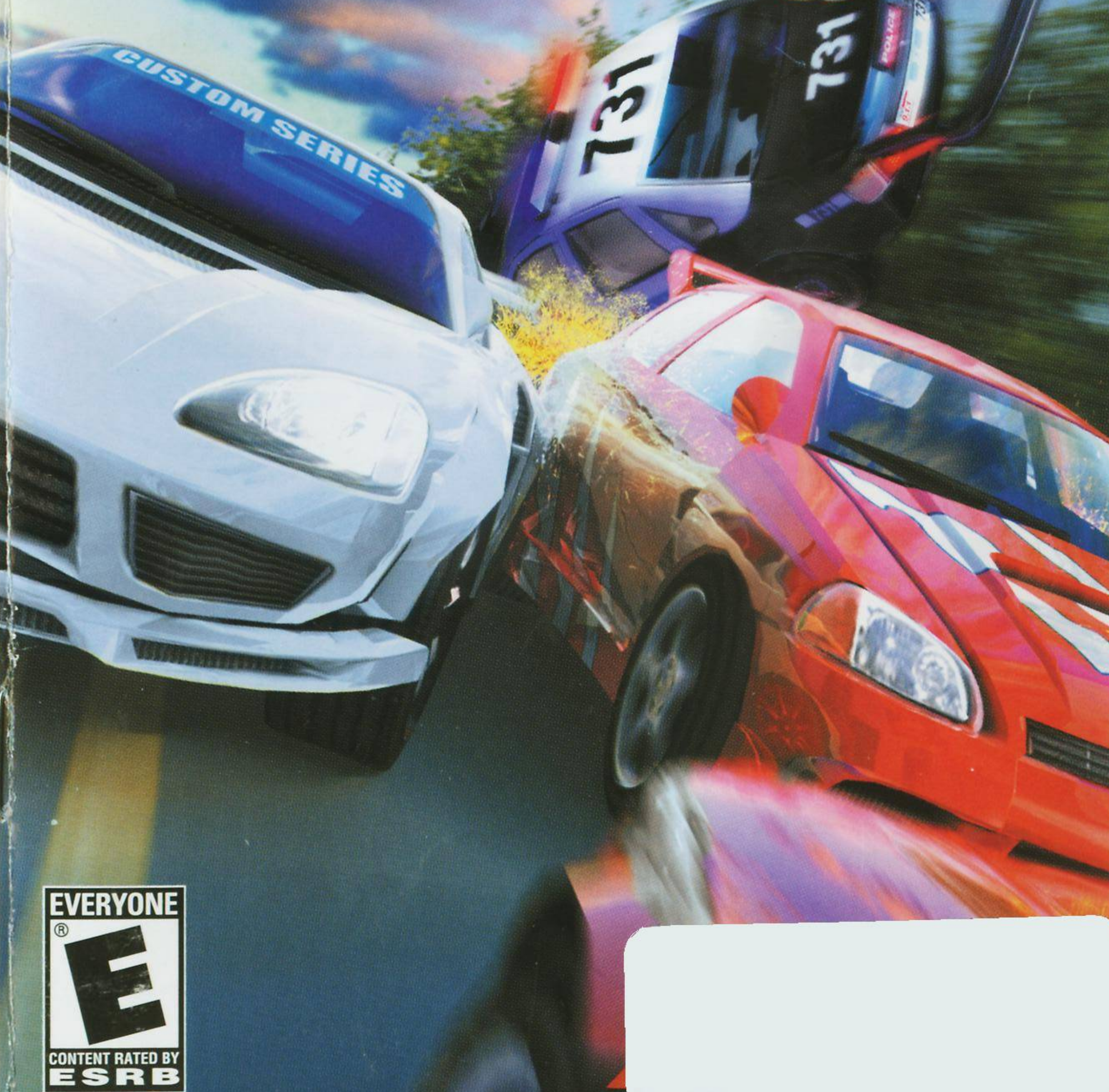



## Safety Information

### About Photosensitive Seizures

A very small percentage of people may experience a seizure when exposed to certain visual images, including flashing lights or patterns that may appear in video games. Even people who have no history of seizures or epilepsy may have an undiagnosed condition that can cause these “photosensitive epileptic seizures” while watching video games.

These seizures may have a variety of symptoms, including lightheadedness, altered vision, eye or face twitching, jerking or shaking of arms or legs, disorientation, confusion, or momentary loss of awareness. Seizures may also cause loss of consciousness or convulsions that can lead to injury from falling down or striking nearby objects.

Immediately stop playing and consult a doctor if you experience any of these symptoms. Parents should watch for or ask their children about the above symptoms—children and teenagers are more likely than adults to experience these seizures.

The risk of photosensitive epileptic seizures may be reduced by sitting farther from the television screen, using a smaller television screen, playing in a well-lit room, and not playing when you are drowsy or fatigued.

If you or any of your relatives have a history of seizures or epilepsy, consult a doctor before playing.

**Other Important Health and Safety Information** The Xbox Instruction Manual contains important health and safety information that you should read and understand before using this software.

### Avoid Damage to Your Television

**Do not use with certain televisions.** Some televisions, especially front- or rear-projection types, can be damaged if any video games, including Xbox games, are played on them. Static images presented during the normal course of game play may “burn in” to the screen, causing a permanent shadow of the static image to appear at all times, even when video games are not being played. Similar damage may occur from static images created when placing a video game on hold or pause. Consult your television owner’s manual to determine if video games can be played safely on your set. If you are unable to find this information in the owner’s manual, contact your television dealer or the manufacturer to determine if video games can be played safely on your set.

Unauthorized copying, reverse engineering, transmission, public performance, rental, pay for play, or circumvention of copy protection is strictly prohibited.

# BURNOUT 2

## POINT OF IMPACT

## CONTENTS

### Using the Xbox Video

**Game System .....2**

**Using the Xbox Controller.....3**

**Connect to Xbox Live .....4**

**Introduction .....6**

**Getting Started .....7**

**Driving Controls .....9**

**The Game Display .....10**

**Game Modes.....12**

**Options .....16**

**Warranty .....21**

**Customer Support.....21**





## Using the Xbox™ Video Game System

1. Set up your Xbox video game system from Microsoft by following the instructions in the Xbox Instruction Manual.
2. Press the power button and the status indicator light will light up.
3. Press the eject button and the disc tray will open.
4. Place the **BURNOUT™ 2** game disc on the disc tray with the label facing up and close the disc tray.
5. Follow the on-screen instructions and refer to this manual for more information about playing **BURNOUT™ 2**.

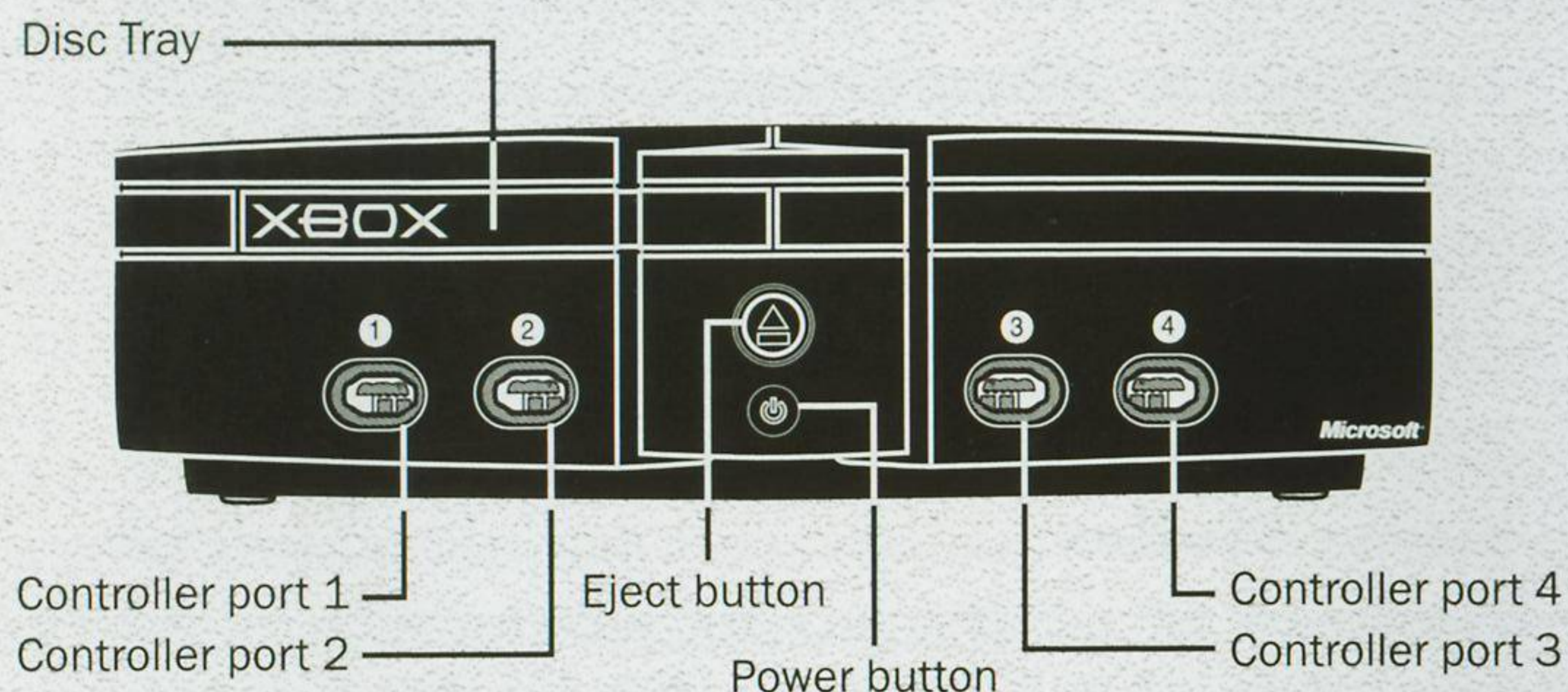

## Avoiding Damage to Discs or the Disc Drive

### To avoid damage to discs or the disc drive:

- Insert only Xbox-compatible discs into the disc drive.
- Never use oddly shaped discs, such as star-shaped or heart-shaped discs.
- Do not leave a disc in the Xbox console for extended periods when not in use.
- Do not move the Xbox console while the power is on and a disc is inserted.
  - Do not apply labels, stickers, or other foreign objects to discs.

## Using the Xbox Controller

1. Connect the Xbox Controller to any controller port of the Xbox console. For multiple players, connect additional controllers to available controller ports
2. Insert any expansion devices (for example, Xbox Memory Units) into controller expansion slots as appropriate.
3. Follow the on-screen instructions and refer to this manual for more information about using the Xbox Controller to play **BURNOUT™ 2**.

**Note: BURNOUT™ 2 is for 1-2 players.**

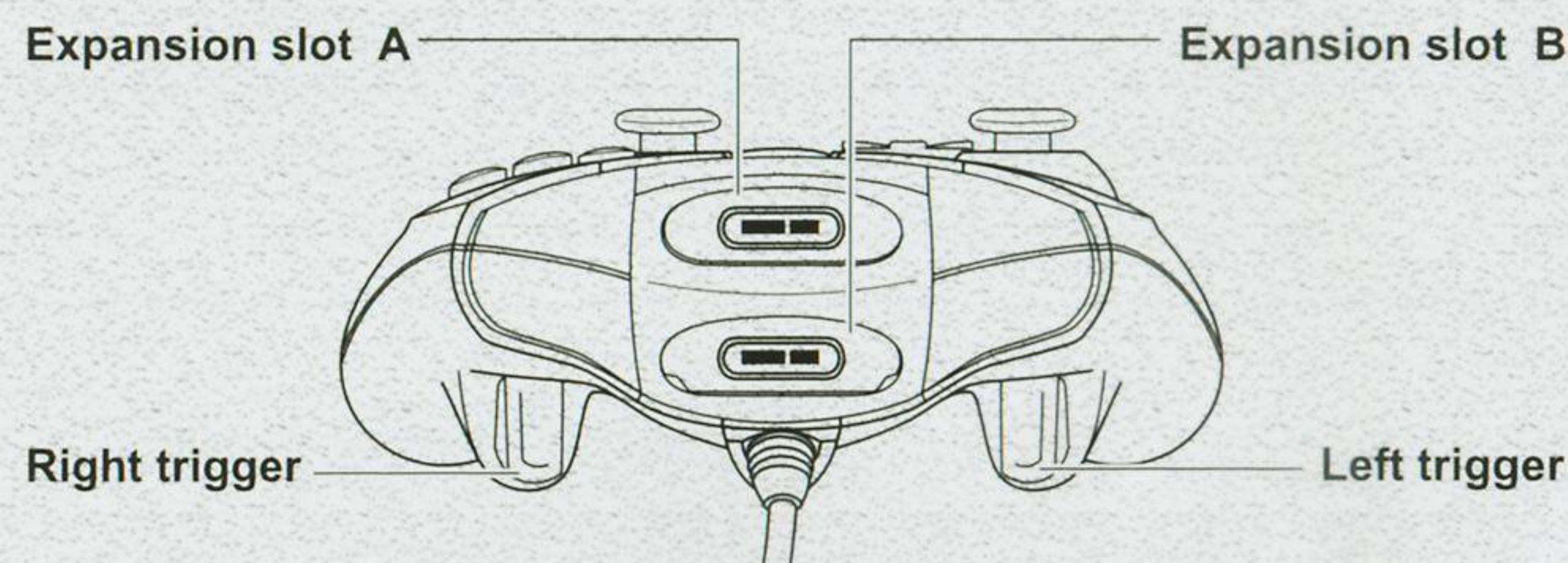



## **Burnout 2:Point of Impact - Xbox Live Online Scoreboards.**

Players can upload their records and compare themselves against the best Burnout players in the world, see page 18 for further information.

### **Connect to Xbox Live**

**Important!** Before using this product, read the Xbox Instruction Manual for important safety information and health warnings.

#### **Step 1: Connect**

To connect your Xbox console directly to broadband, see diagram A. Or, to share your broadband connection with a PC, see diagram B.

For more details and other home networking options, including Internet connection sharing, see [www.xbox.com/live](http://www.xbox.com/live).

##### **A. Direct Connection**

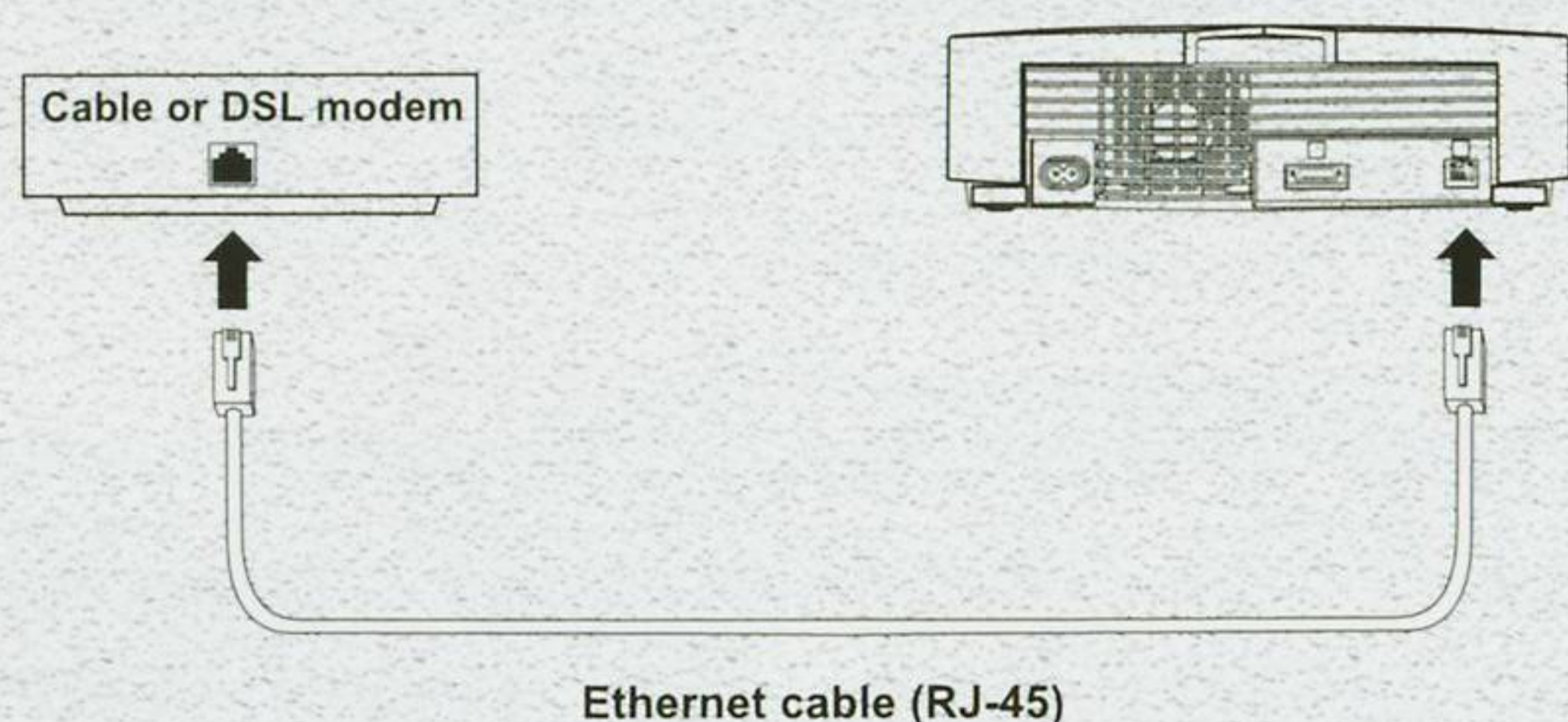

##### **B. Shared Connection**

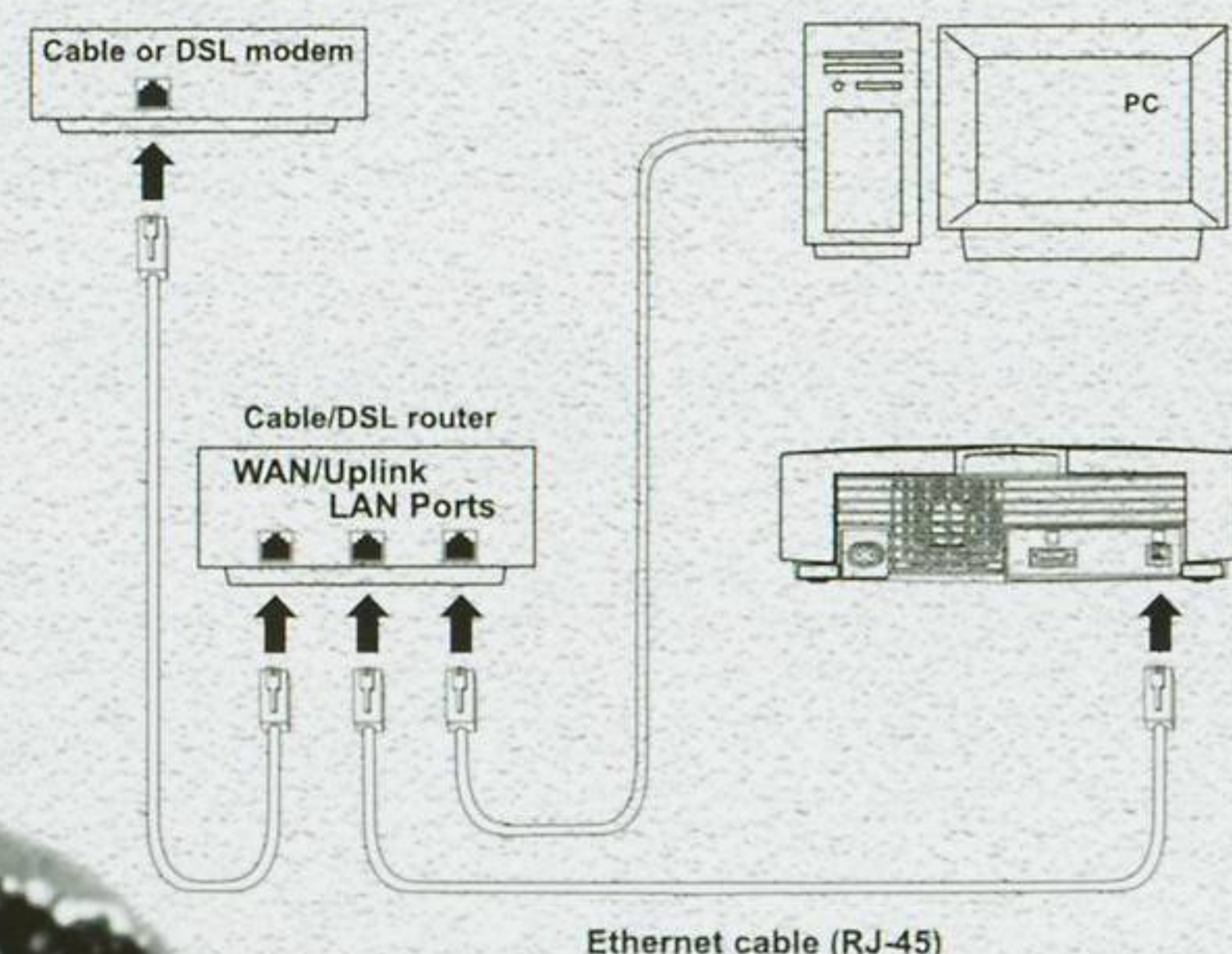

#### **Step 2: Go Live**

Important! Xbox Live™ is a subscription service. You will need a subscription code to set up an Xbox Live account and play online. To find out how to get a subscription code, visit your local retailer or see [www.xbox.com/live](http://www.xbox.com/live).

You'll need to set up an Xbox Live account to play games online. Here's how:

1. Insert an Xbox Live Starter Kit disc or game disc into the disc tray. Check game packaging to see if the game supports Xbox Live play.
2. From within the game, select the option for Xbox Live.

At this point, the Xbox console will try to go online. If it works, create your Xbox Live account by following the instructions on screen and entering your subscription code when prompted.

If the Xbox console can't go online automatically, you'll get an error message. Go on to Step 3.

#### **Step 3: Configure (if necessary)**

If you can't go online automatically, use Network Setup in the Xbox Dashboard to enter some network settings. You may need to enter information such as a host name, a MAC address, or an ISP user name and password. Contact your broadband service provider if you don't have this information. Once you have the information, enter it in the Xbox Dashboard.

#### **Need more help?**

Should you have any problems connecting to the Xbox Live service, do not attempt to take apart, service, or modify the Xbox console or peripherals in any way. Doing so could present the risk of serious injury or death from electric shock or fire and will also void your warranty. For additional assistance see [www.xbox.com/live](http://www.xbox.com/live) or call the Customer Support number:

- United States and Canada: 1-800-4MY-XBOX (1-800-469-9269)
- TTY users (requires special equipment for hard of hearing):  
United States and Canada: 1-866-740-9269 or 1-425-635-7102



## INTRODUCTION

If you longed for more high-speed driving action, your prayers have been answered. Welcome to a world of fast racing, modified street-mean vehicles and incredible carnage.

### WELCOME TO BURNOUT™ 2 - POINT OF IMPACT.

Your aim is to race to the finish line through a series of checkpoints as quickly as possible.

Try a full Championship, unlocking modes and vehicles as you blaze over the asphalt trying to live long enough to be the GP prizewinner.

If you've got a bunch of friends with more courage than sense, you've found the ideal partners for our Multi Player contests. Ram them off the road in Pursuit, compete to cause the most damage in Crash, or simply beat them to the finish line in Single Race Mode.

You're about to show the world the real meaning of road rage but remember: it's only a game... We do not recommend that you try anything you experience while playing Burnout 2 in real life! Keep it on the screen and off the streets!

## GETTING STARTED

### Navigating menus and screens

Pressing up or down on the directional buttons will highlight your selection, pressing the **A** button will confirm your selection. Pressing left or right on the directional pad will show you other menus.

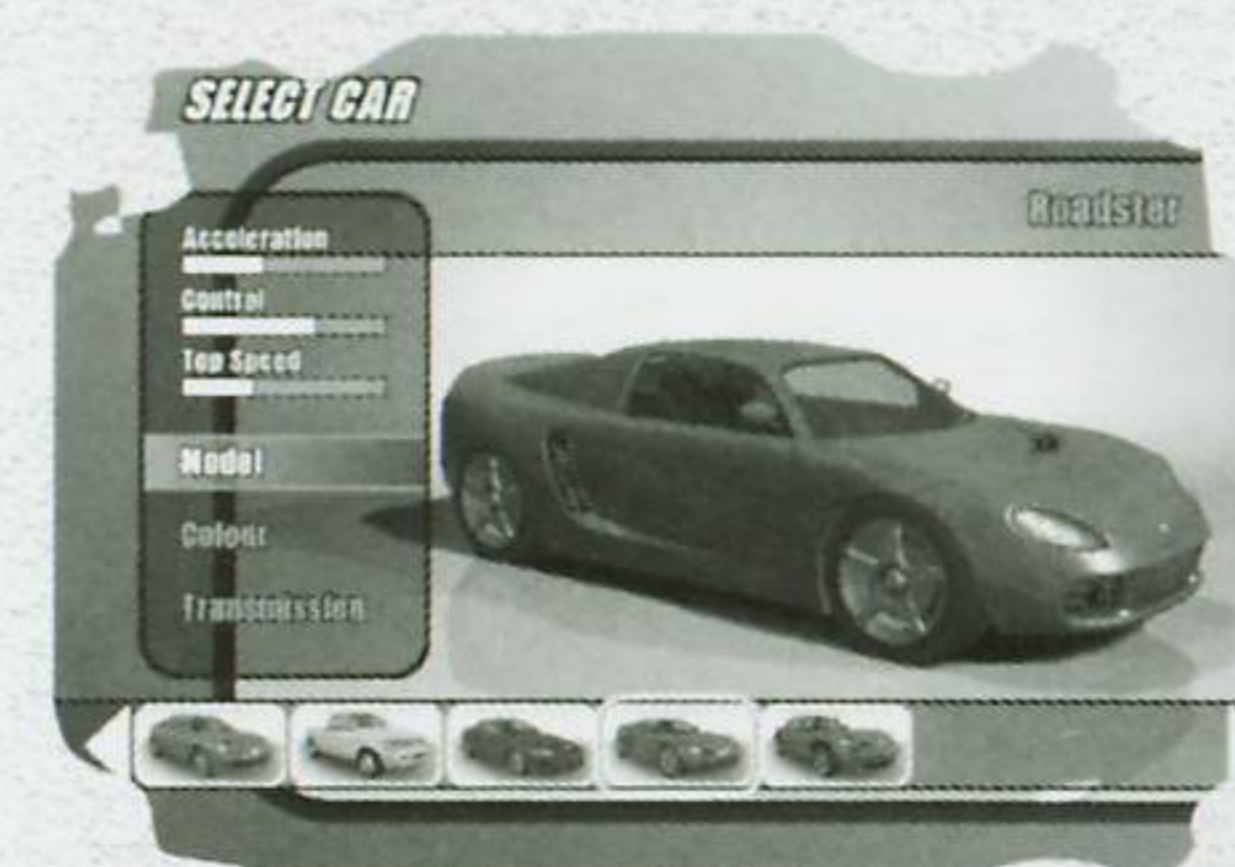

On subsequent screens, such as the "Car Select" menu shown here, pressing up or down will highlight your selection, and pressing left or right will change options relating to that selection. For example, selecting color will allow you to use left or right to choose a color from the carousel at the bottom of the screen.

Use the **right thumbstick** to rotate the car model on screen.



## MAIN MENU: Single Player

At the title screen, press the **START** button to advance to the Main Menu. You will see only one choice.



### Custom Championship

Once you've completed Championship mode, this special Custom Championship mode becomes available. See page 13 for details.

### Championship

Push your driving skills to the limit in Championship Mode. Please see Championship on page 12 for further information.

### Single Race

Race any unlocked car on any unlocked track in this mode. Please see Single Race on page 14 for further information.

### Time Attack

Race against the clock to set the hottest lap time. Please see Time Attack on page 14 for further information.

### Offensive Driving 101

Choose this option to learn how to drive Burnout™ 2 style. Please see Offensive Driving 101 on page 12 for further information.

### Crash

A great part of the original Burnout has now got its own game mode. Please see Crash on page 14 for further information.

### Pursuit

Once you unlock this mode, it's your turn to play copper as you pursue dangerous law breakers.

## Options

This menu is used to specify various game settings. For more details, please see Options on page 16 for further information.

## Records

View your best times and achievements so far. Please see Records on page 17 for further information.

# DEFAULT CONTROLS

An alternate controller configuration is available from the Options menu.

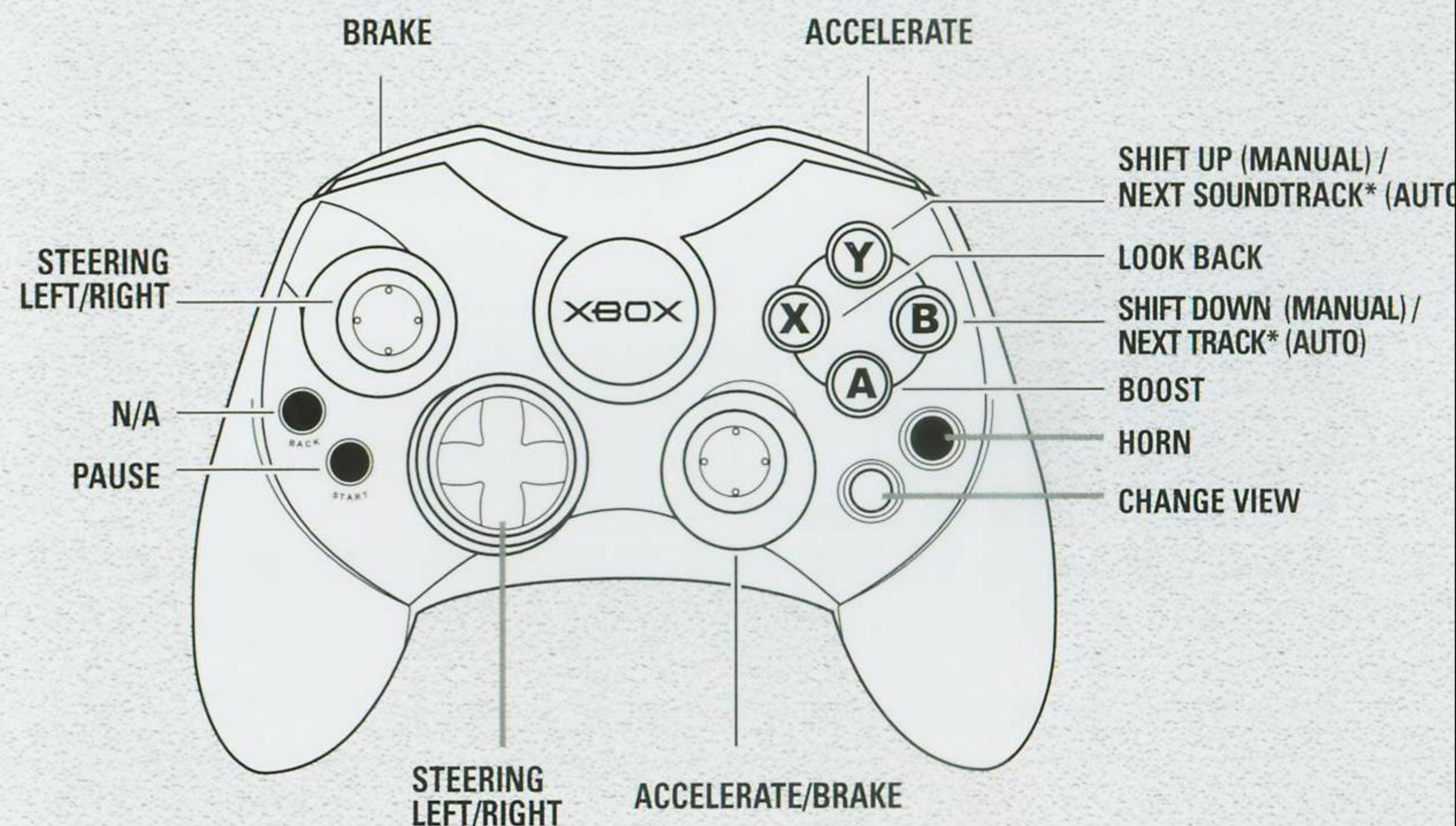

\*only when custom soundtracks are chosen from the options menu



# THE GAME DISPLAY

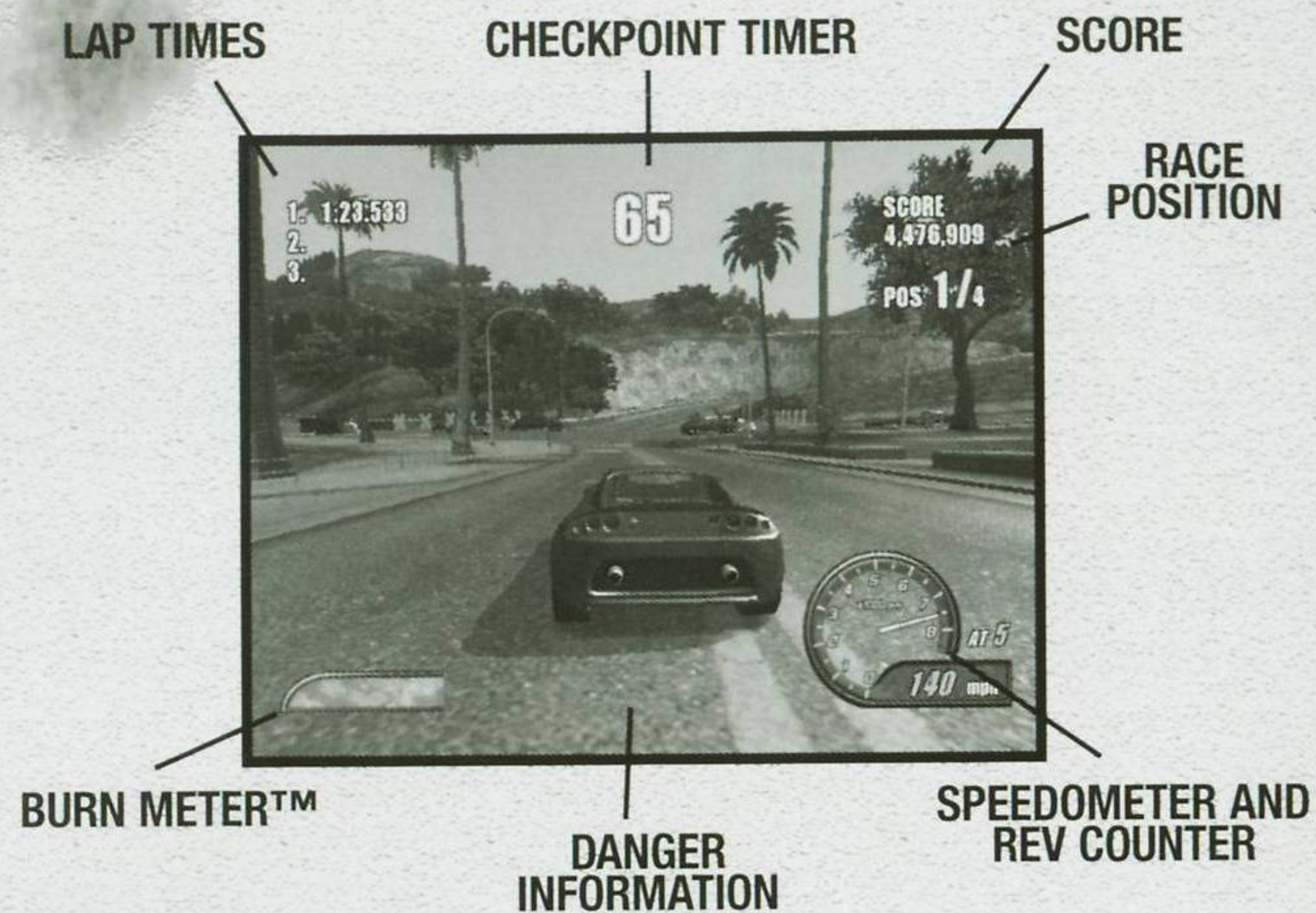

1. Checkpoint Timer
2. Lap Times. The number of slots shows how many laps in the race. Your best lap time in that race is highlighted in yellow.
3. Burn Meter™
4. Danger Information
5. Speedometer and Rev Counter
6. Race position
7. Score

Other game modes have slightly different screen layouts.

## VEHICLE SELECTION

BURNOUT™ 2 lets you push everyday vehicles to their limit, from compacts and sports cars to muscle cars and hot rods!

The type of vehicle you choose is related to the difficulty of the game. The compact car is EASY difficulty, with nimble handling for weaving in and out of the traffic, while the muscle cars are HARD difficulty, fast and powerful to drive!

## TRANSMISSION SELECTION

The player can choose between Automatic (AT) and Manual (MT) transmission. Expert players should choose to drive with Manual transmission!

## COURSE SELECTION

There are 30 courses to drive. New Courses are unlocked in Championship Mode. The courses are located in one exciting peninsula. There are also some Point-to-Point Races. Race from one course into another!



**PACIFIC INTERNATIONAL AIRPORT:** Race around a busy international airport. Watch for lots of traffic!

**PALM BAY:** Slide your car at breakneck speed through busy downtown streets. A fast city course to test your skill!

**INTERSTATE 88:** Experience a high speed driving sensation! This stage connects the beach to the mountains!

**BIG SURF:** Speed along coastal roads! A twisty course with a feeling of California!

**SUNRISE VALLEY:** A grid-based city course awaits you. Feel the heat of the desert!

**CRYSTAL SUMMIT:** Ascend into the heavenly resort of Crystal Summit ski area! Watch out for falling snow!



# GAME MODES

BURNOUT™ 2 is all about dangerous and aggressive driving. You'll be scored in races by how mad your manner behind the wheel is, earning points for these unusual "skills":

- **Drift distance** (distance spent sliding around corners)
- **Oncoming** (distance spent travelling at speed on the wrong-side of the road)
- **Burnout Chain** (the number of Burnouts in a row)
- **Distance spent in the air** (distance spent with all four wheels off the ground)

Your skill in these disciplines contributes both to the rate of increase of your Burn Meter™ and your score.

## OFFENSIVE DRIVING 101

Learn how to drive "Burnout 2 style." It's the only 'bad driving' license in the world! In six short lessons we'll teach you all you need to know about driving dangerously at high speeds. Get at least a bronze medal in all lessons to unlock more game modes!

## CHAMPIONSHIP

In Championship mode, the player races through a series of GP races, unlocking additional Courses and Modes as they progress. New Courses that are unlocked in Championship Mode then become available in other Game Modes.

There are two main Championship seasons – the Standard Championship and the Custom Series Championship.

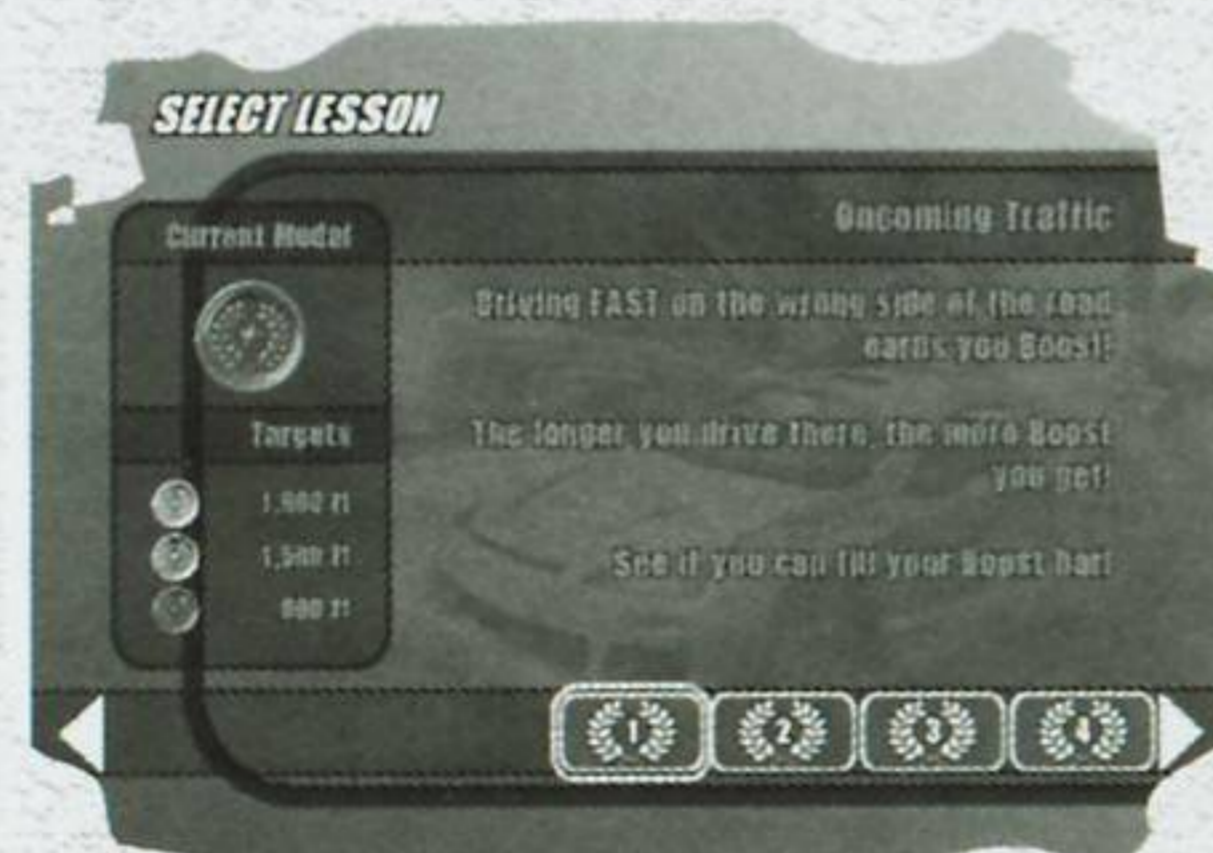

### Championship Progression – Standard Championship.

You race against three computer opponents. You are ranked on a leader board at the end of each race, 3 points for 1st place, 2 points for 2nd place, 1 point for 3rd place and zero for fourth. The player with the most points accumulated at the end of all the races in a GP wins! You must win a GP to unlock the next one in the series.

There are four GP's in the Standard Championship season, including three point to point races.

There are 3 Pursuit Races to unlock in this season.

There are 4 Face/Off Races to unlock in this season.

The final race in the Standard Championship is the Custom Series Qualifier. If you complete this event, you will unlock the Custom Series Championship and earn your first Custom Series vehicle.

## CUSTOM SERIES CHAMPIONSHIP

Custom Series vehicles are the specialist, modified, tuned-up counterparts of the seven initial standard vehicles. They are race-tuned, each complete with bodykits, decal sets, tuned engines and improved handling. These are the fastest and most furious cars in the game.

### Championship Progression – Custom Series Championship

When the Series is unlocked, the player must compete in a new series of GP races. In these races, the player will race against CPU opponents all driving Custom Series vehicles.

There are 4 GP's in the Custom Series Championship.

There are 3 Pursuit Races to unlock in this season.



## **SINGLE RACE**

In Single Race, players can challenge any unlocked courses. Initially only three Courses are available. More Courses become available after they have been unlocked in Championship Mode. Players always race against three other AI drivers in this mode. This is a great way to hone your driving skills before taking on Championship Mode.

## **TIME ATTACK**

In Time Attack Mode, one player can challenge any unlocked Course in a race against the clock. The player will always race alone in this mode. There are no CPU opponents in this mode.

## **PURSUIT**

This mode is unlocked through Standard Championship progression. In this mode, the player must chase a target vehicle and crash it off the road. In 1P Mode, the player will always drive the Police Car.

## **CRASH**

Smash your car into the traffic to see how much insurance damage you can rack up! There are three stages unlocked at the start of the game. Score a Bronze Medal at each stage to unlock more stages.

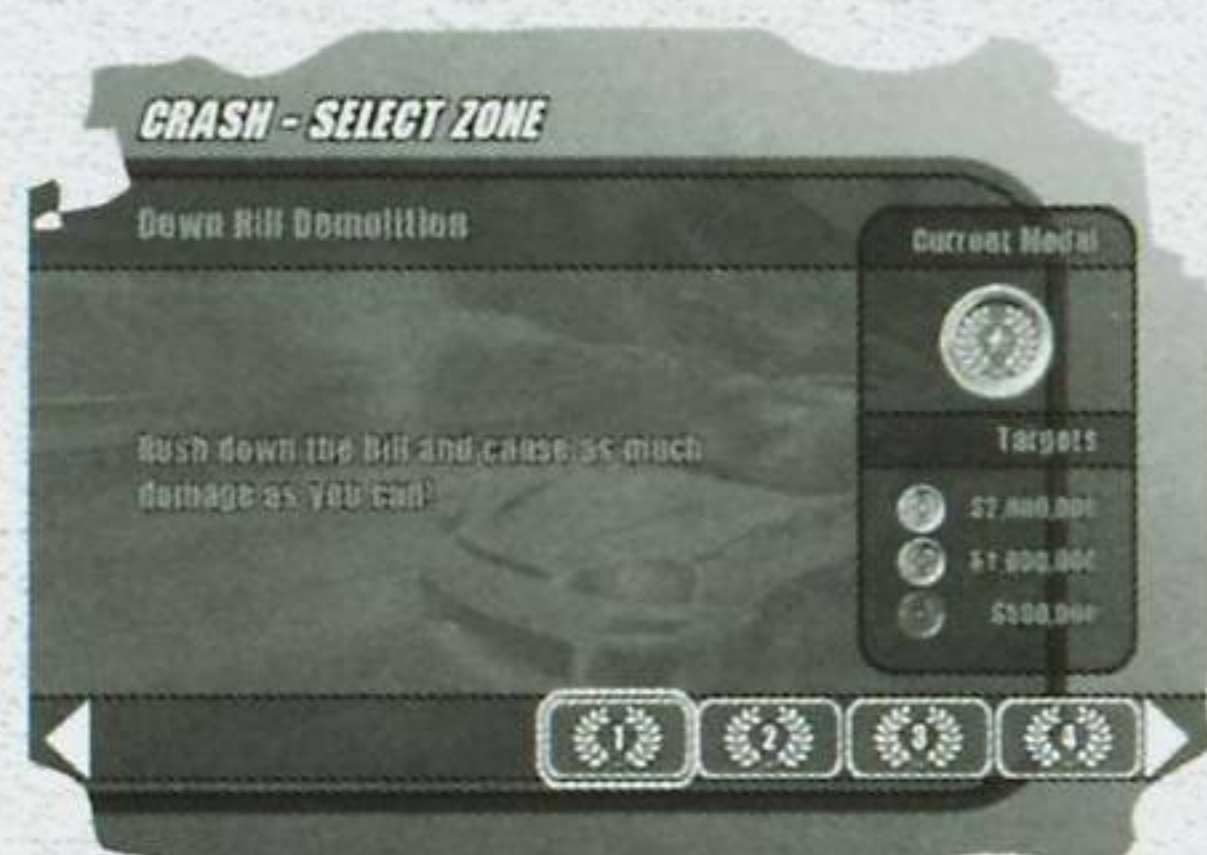

## **MULTIPLAYER**

Some options in this menu are highlighted only if two Xbox controllers are plugged into the controller ports. In Multiplayer Mode, two players compete on a split screen.

Each player chooses the car they want to drive on the Vehicle Selection Screen. Once each player has selected the cars they want to race, the Course Selection screen is displayed. On this screen, Player One will choose which Course is to be raced.

On a standard (4:3) TV, the screen is split showing Player One at the top and Player Two at the bottom. On a widescreen (16:9) TV, the screen is split showing Player One on the left and Player Two on the right.

## **MULTIPLAYER SINGLE RACE**

Two players can race against two CPU opponents. Any course unlocked in single player progression can be raced.

## **MULTIPLAYER PURSUIT MODE**



Once unlocked, two players can race any unlocked vehicle against any unlocked vehicle on any previously unlocked courses. Player One will always drive the pursuit vehicle. Player Two will always drive the target vehicle. If the target gets rammed ten times, the pursuit is over.

## **MULTIPLAYER CRASH MODE**

Challenge up to FOUR players in a Burnout™ 2 Crash Tournament. Each player gets an attempt at causing the most damage in three specially created crash junctions, which can be selected in groups of three from a total of thirty.

The player with the highest total score at the end of the tournament wins! Choice of car, speed and angle of approach can make all the difference! Good luck and make sure your seat belt is securely fastened!



## **OPTIONS**

### **Controls**

This menu is used to change the controller configuration, or set the vibration setting ON or OFF.



### **Audio Options**

This menu is used to turn the music and sound effects UP or DOWN during races, replays, and menu screen navigation.

### **Music Selection**

This menu is used to choose custom soundtracks from music stored on your Xbox console.

### **Load / Save**

This menu is used to load or save your game progress.

### **Cheat Menu**

This menu is used to access any SPECIAL or EXTRA modes that may be unlocked.

### **Credits**

This will display the Burnout 2 development team credits.

## **RECORDS**

### **MENU**



### **View Profile**

This will display the current driver profile.

### **Track Records**

This will display the best lap times, total times, score records and skill records for each course.

### **Time Attack Records**

This will display the best times per course so far from Time Attack mode.

### **Crash Records**

This will display the biggest crash scores so far for each unlocked crash junction.



# Xbox Live

## Burnout 2:Point of Impact - Xbox Live Online Scoreboards.

Players can upload their records and compare themselves against the best Burnout players in the world in the following categories:



- **Track Records** – Total race times for each track
- **Skill Records** – Overall skill records
- **Crash Records** – Biggest crashes for each zone
- **Overall Records** – Are you the world's best Burnout 2 player?

Within each of the above categories, the following options are available:

- **Your Records** – Where do you stand in the worldwide rankings?
- **World Records** – Check out the top players in the world.
- **Friends Records** – You can also check out how you match up to the players on your Friends list.

## Acclaim QA Credits

### Manager

Brian Regan

### Supervisors

Matthew Canonico

Bill Handworth

### Senior Lead Game Analyst

Bonchi Martinez

### Lead Game Analysts

James Ackermann

Martin Glantz

### Project Leads

Keith Bishop

Orland Apiado

### Testers

Chris Zith

Dan Sciarrino

Lloyd Thompson

Brett Golub

Al Gatling

Jason Majewski

Gary Yashian

Seung Park

Irania Colon



