



MINI DELUXE



SERVICE MANUAL



- Before using this product, read this **MANUAL** carefully to understand the contents stated herein.
- After reading this **MANUAL**, be sure to keep it available nearby the product or somewhere convenient in order to be able to refer to it whenever necessary.

Manufactured in the UK by



MANUFACTURING DIVISION (U.K.)



CONTENTS

1.	BEFORE USING THIS PRODUCT	1
1.1.	INSPECTIONS IMMEDIATELY AFTER TRANSPORTING THE PRODUCT TO THE LOCATION	2
2.	INTRODUCTION TO THIS SERVICE MANUAL	4
3.	HANDLING AND INSTALLATION PRECAUTIONS	5
4.	NAME OF PARTS	6
5.	ACCESSORIES	7
6.	ASSEMBLING	8
6.1.	SECURING IN PLACE (LEG ADJUSTER ADJUSTMENT)	9
6.2.	POWER SUPPLY, AND EARTH CONNECTION	10
6.3.	CONNECTION TO THE POWER SUPPLY	10
6.4.	MACHINE CHECK	11
7.	PRECAUTIONS TO BE TAKEN WHEN MOVING THE MACHINE	18
8.	OPERATION	19
8.1.	TROUBLESHOOTING	20
9.	HOW TO PLAY	21
9.1.	GAME OUTLINE	22
9.2.	ITEMS	25
9.3.	PLAY HINTS	26
10.	MAINTENANCE INSTRUCTIONS	27
10.1.	EXPLANATION OF TEST AND DATA DISPLAY	27
10.1.1.	VTS ASSEMBLY	28
10.1.2.	SYSTEM TEST MODE	29
10.1.3.	GAME TEST MODE	42
10.1.4.	ERROR CODES	63
10.2.	COIN MECH INSTALLATION AND CREDIT BOARD SET UP	67
10.2.1.	INTRODUCTION	67
10.2.2.	VTS CREDIT BOARD OPTION SETTINGS	69
10.2.3.	PRICE OF PLAY SETTINGS UK	70
10.2.4.	PRICE OF PLAY SETTINGS EURO	71
11.	CONTROLLER UNIT (GUN)	72
12.	REPLACEMENT OF FLOURESCENT LAMPS	78
13.	PERIODIC INSPECTION TABLE	80
14.	TROUBLESHOOTING	81
15.	GAME BOARD	83
15.1.	REMOVING THE GAME BOARD	84
15.2.	SHIPPING THE GAME BOARD	85
15.3.	COMPOSITION OF GAME BOARD	85
16.	DESIGN RELATED PARTS	86
17.	PART LIST	87
17.1.	ASSY TOP - (HDF-00002KUK)	87
17.2.	ASSY CABINET MDX – (HDF-10001UK)	88
17.3.	ASSY CABINET LOWER – (HDF-1500UK)	89
17.4.	ASSY SUB CABI MONITOR – (HDF-1071UK)	91
17.5.	ASSY MONITOR UK – (HDF-1070UK)	92
17.6.	ASSY SENSOR MTG – (HDF-1085UK)	94
17.7.	ASSY AC UNIT – (HDF-1530UK)	94
17.8.	ASSY FOOT BASE – (HDF-1520UK)	95
17.9.	ASSY FAN UNIT UK – (HDF-1530UK)	95
17.10.	ASSY CONTROL PANEL – (HDF-1540UK)	96
17.11.	ASSY LIGHT BOX – (HDF-1095UK)	96
17.12.	ASSY POWER BASE – (HDF-4700UK)	97
17.13.	ASSY ELEC LEFT – (HDF-4500UK)	98
17.14.	ASSY ELEC RIGHT – (HDF-4600UK)	99
17.15.	ASSY INSTALLATION KIT MDX – (HDF-INST-MDX)	99
18.	WIRE COLOUR CODE TABLE	100
19.	APPENDIX A - ELECTRICAL SCHEMATIC	101

1. **BEFORE USING THIS PRODUCT**

To ensure the safe usage of the product, be sure to read the following before using the product. The following instructions are intended for the use of qualified service personnel only. After carefully reading and sufficiently understanding the instructions should any activity be carried out on the product. Only qualified service personnel should carry out maintenance on the product.

Terms such as WARNING!, CAUTION, and IMPORTANT! Are used where an explanation is given which requires special attention, depending on the potential risk. SEGA is not responsible for injury or damage caused by use in a manner contrary to the instructions stated in this document. In order to prevent accidents warning stickers and printed instructions are applied in the places where a potentially hazardous situation relating to the product could arise. Be sure to comply with these warnings.



WARNING

Indicates that mishandling the product by disregarding this warning will cause a potentially hazardous situation which can result in death or serious injury.



CAUTION

Indicates that mishandling the product by disregarding this caution will cause a potentially hazardous situation which can result in personal injury and or material damage.



IMPORTANT

This is cautionary information which should be complied with when handling the product. Indicates that mishandling the product by disregarding this will cause a potentially hazardous situation which may not result in personal injury but could damage the product.

Be sure to turn off the power and disconnect from the mains supply before working on the machine.

Ensure that the correct fuse(s) is fitted to the machine.

Details of the correct fusing of the machine are enclosed in the Service Manual.

Ensure that only qualified Service Engineers perform any maintenance work on the machine.

Specification changes, removal of equipment, conversion and/or addition, not designated by SEGA are not permitted and will invalidate this product's CE conformity.

The parts of the product also include any warning labels or safety covers for personal protection etc. A potential hazard will be created if the machine is operated while any parts have been removed. Should any doors, lids or protective covers be damaged or lost, do not operate the product. SEGA is not liable in any whatsoever for any injury and/or damage caused by specification changes not designated by SEGA.

Before installing the product, check for the Electrical Specification Sticker, SEGA products have a sticker on which the electrical specifications are detailed. Ensure that the product is compatible with the power supply voltage and frequency requirements of the location in which the machine is to be installed.

Install and operate the machine only in places where appropriate lighting is available, allowing warning stickers to be clearly read.

To ensure maximum safety for both customers and operators, stickers and printed instructions describing potentially hazardous situations are applied to places where accidents could occur. Ensure that where the product is operated has sufficient lighting to allow any warnings to be read. If any sticker or printed warning is removed or defaced, do not operate the machine, until it has been replaced by an identical item.

When handling the monitor, be very careful. (Applies only to product with monitor)

Some of the monitor (TV) parts are subject to high tension voltage. Even after turning off the power some components are still occasionally subject to high tension voltage. Monitor repair and replacement should be performed by qualified service engineers only.

In cases where commercially available monitors and printers are used only the contents relating to this product are stated in this manual. Some commercially available equipment has functions and reactions not stated in this manual. Read this manual in conjunction with the specific manual of such equipment.

Descriptions contained herein may be subject to change without prior notification.

The contents described herein are fully prepared with due care. However, should any question arise or errors be found please contact SEGA.

1.1. INSPECTIONS IMMEDIATELY AFTER TRANSPORTING THE PRODUCT TO THE LOCATION

Normally, at the time of shipment, SEGA products are in a state to allowing usage immediately after transporting to the location. Nevertheless, an irregular situation may arise during transportation preventing this. Before turning on the power, check the following points to ensure that the product has been transported safely.

- Are there any dented parts or defects (cuts, etc.) on the external surfaces of the product.?
- Are castors and leg adjusters present and undamaged?
- Do the power supply voltage and frequency requirements meet with the local supply?
- Are all wiring connectors correctly and securely connected? Unless connected in the correct direction, connector connections cannot be made successfully. Do not insert connectors forcibly.
- Are all IC's of each IC BD firmly inserted?
- Does the power cord have any cuts or dents?
- Do fuses meet the specified rating?
- Are such units such as monitors, control equipment, IC BD, etc. firmly secured?
- Are all earth wires connected?
- Are all accessories available?
- Can all doors and lids be opened with the accessory keys and/or tools?

CONCERNING THE STICKER DISPLAY

SEGA product has stickers describing the product manufacture number (Serial Number) and electrical specification. If you require service assistance you will require the Serial Number. Identical machines may have different parts fitted internally. Only by quoting the Serial Number will the correct parts be identified.

CONCERNING WARNING STICKERS

SEGA product has warning displays on stickers, labels or printed instructions adhered/attached to or incorporated in the places where hazardous situations can arise. The warning displays are intended for the accident prevention of customers and service personnel.

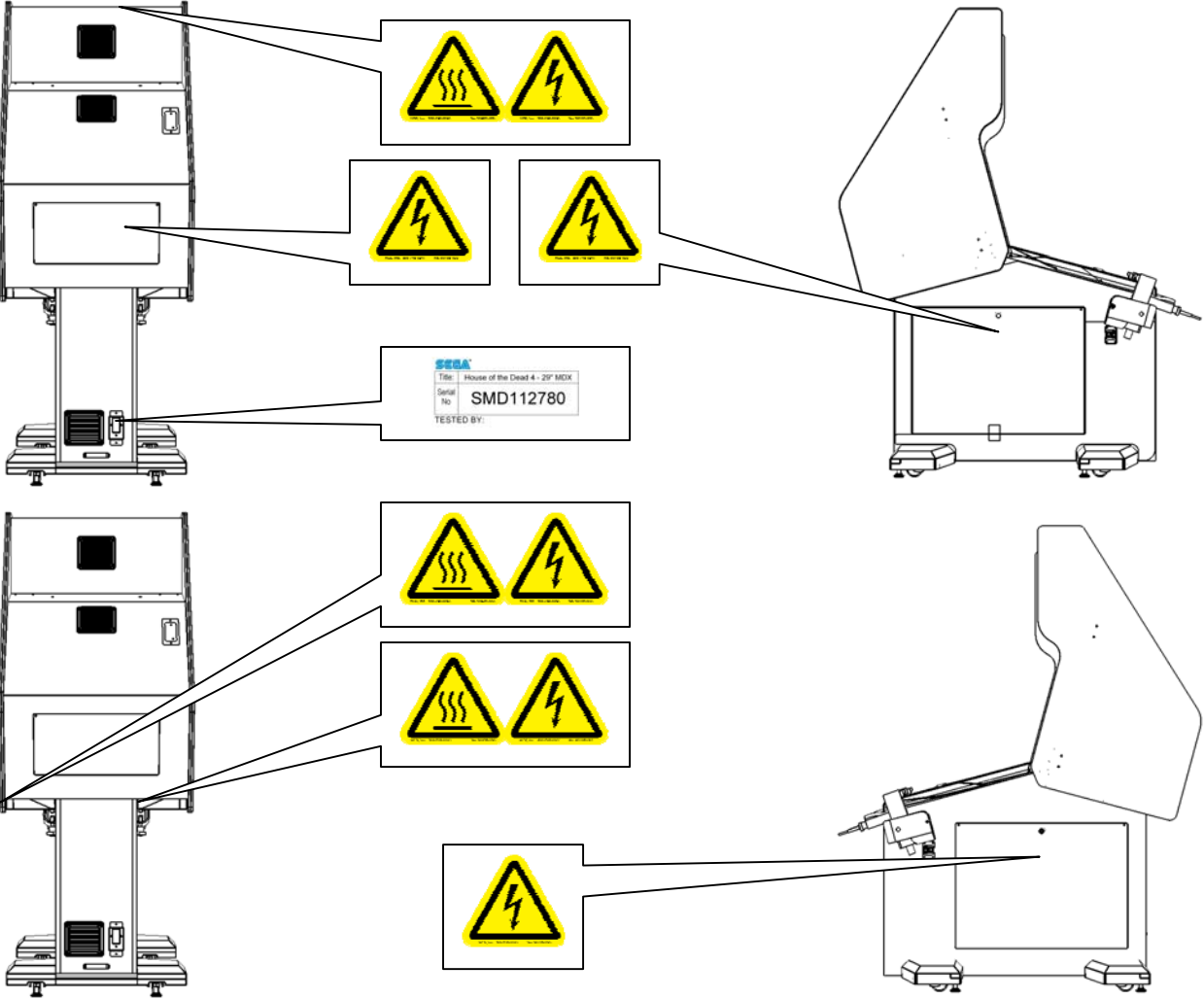

SPECIFICATIONS		
Installation Space (cm):	765mm (30.1in) X 1405mm (55.3in)	
Height (cm):	1975mm(77.8in)	
Weight (cm):	180Kg's	
Power, Max:	Rated Voltage (V.AC):	220~240
	Rated Current (A):	2A

Note: Descriptions in this manual are subject to change without prior notice.

2. INTRODUCTION TO THIS SERVICE MANUAL

SEGA ENTERPRISES LTD., supported by its experience in electronic high technology of VLSI's, microprocessors etc. and with a wealth of experience, have for more than 30 years been supplying various innovative and popular games to the world market. This Service Manual is intended to provide detailed descriptions together with all the necessary information covering the general operation of electronic assemblies, electromechanicals, servicing controls, spare parts, etc. as regards HOUSE OF THE DEAD 4 MINI DELUXE, a new SEGA product. This manual is intended for those who have knowledge of electricity and technical expertise especially in IC's, CRT's, microprocessors etc.. Carefully read this manual to acquire sufficient knowledge before working on the machine. Should there be any malfunction, non technical personnel should under no circumstances touch the interior systems. Should such a situation arise contact the nearest branch listed below or our head office.

SEGA AMUSEMENTS EUROPE LTD./ SEGA SERVICE CENTRE

Suite 3a Oak House,
12-22 West Street
Epsom
Surrey
United Kingdom,
KT18 7RG.

Telephone: +44 (0) 1372 731 820
Fax: +44 (0) 1372 731 849

3. HANDLING AND INSTALLATION PRECAUTIONS



- Installation and commissioning should only be carried out by a QUALIFIED SERVICE PERONNEL.

When installing or inspecting the machine, be very careful of the following points and pay attention to ensure that the player can enjoy the game safely.

The game must NOT be installed under the following conditions:

- Outside, the game is designed for indoor use only.
- In areas directly exposed to sunlight, high humidity, dust, excessive heat or extreme cold.
- In locations that would present an obstacle in the case of an emergency i.e. near fire equipment or emergency exits.
- On unstable surfaces or surfaces subject to vibration.
- Where liquids, other than routine cleaning, may come into contact with the game.

Important:

- This machine should only be installed by Qualified Service Personnel.
- Ensure that the line supply voltage matches that of the transformer input tapping. For more information see the section in this manual dealing with changing the transformer voltage.
- Please note that the input voltage of the machine has been set during manufacture to 230V AC
- Be sure to switch the supply power OFF and remove the mains supply plug from the machine before any work is carried out on the machine.
- Do not attempt to repair the PCB's (Printed Circuit Boards) yourself. This will void the warranty. The PCB's contain static sensitive devices that could be damaged.
- Always return a faulty part to your distributor with adequate packaging and protection.
- When removing the plug from the mains always grasp the plug not the cable.
- Do not use a fuse that does not meet the specified rating.
- Make sure all connections are secure before applying power.



- Ensure that the mains lead is not damaged. If the main lead is damaged in any way there could be a danger of electrical shock or fire hazard.
- Ensure that the power supply is fitted with a circuit protection device. Using power supply without circuit protection is a fire hazard.

4. NAME OF PARTS

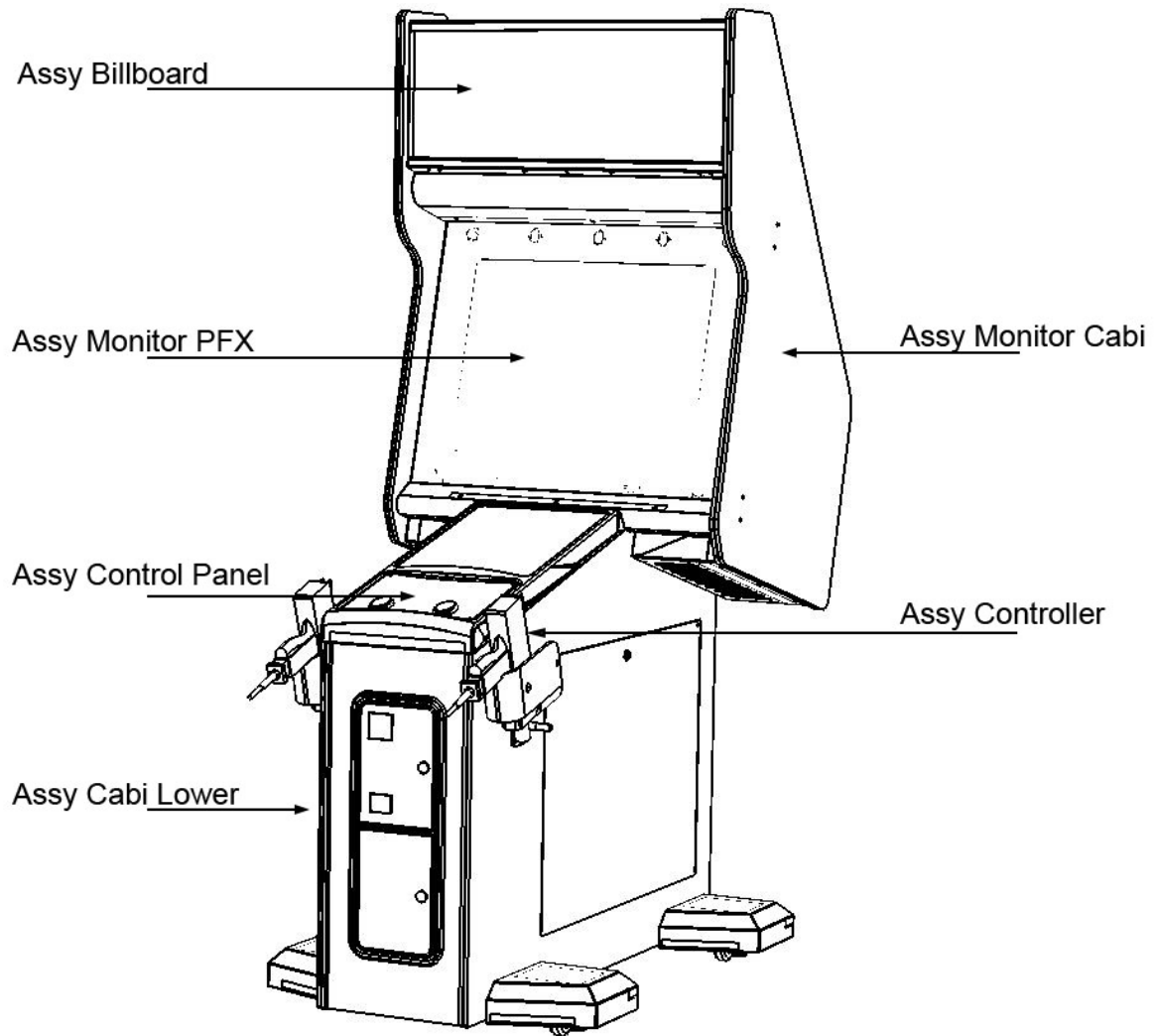

	Width (cm)	Depth (cm)	Height (cm)	Weight (kg)
When Assembled	76.5	140.5	197.5	Approx. 180

5. ACCESSORIES

The machine is supplied with an installation kit. Please ensure the following parts are supplied:

No.	PART NUMBER	QTY	DESCRIPTION
*1	440-CS0186UK	1	STICKER C EPILEPSYB MULTI
*2	SAECE-XXX	1	DECLARATION OF CONFORMITY
*3	HDF-1056UK	1	DECAL BUTTON PLATE HDF MDX MULTI
*4	540-0043-91	1	L-WRENCH FOR HEX SOC 3MM
*20	601-11691	1	CARTON BOX LBG
*401	0S1019	2	SELF SEAL BAG
*402	420-6908-03UK	1	SERVICE MANUAL HDF MDX
*404	350-5801	2	MOTOR DC5V TG-01H
*405	590-5080	2	SW MICRO TYPE (SS-5GL2)
*406	514-5078-3000	1	FUSE 3000MA T 20MM CERAMIC
*407	514-5078-5000	1	FUSE 5000MA T 20MM CERAMIC

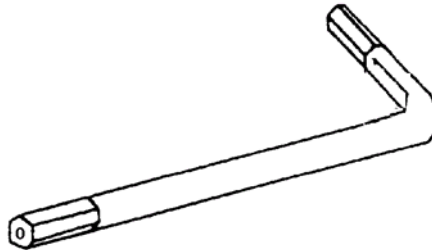

540-0043-91 L-WRENCH FOR HEX SOC 3MM

6. ASSEMBLING



- Perform the assembly work by following the procedure herein stated. Failing to comply with the instructions can cause an electric shock.
- Assembling should be performed as per this manual. Since this is a complex machine, erroneous assembling can cause an electric shock or damage to the machine resulting in not functioning as per performance.

When carrying out the assembly work, follow the procedure in the following 3 item sequence:

- STEP 1 SECURING IN PLACE (LEG ADJUSTER ADJUSTMENT)
- STEP 2 POWER SUPPLY, AND EARTH CONNECTION
- STEP 3 CONNECTION TO THE POWER SUPPLY
- STEP 4 MACHINE CHECK

6.1. SECURING IN PLACE (LEG ADJUSTER ADJUSTMENT)



- Make sure that all of the leg adjusters are in contact with the floor. If they are not, the cabinet may move causing an accident.

This machine has 4 castors and 4 leg adjusters. When the installation position is determined, bring the leg adjusters to come into contact with the floor directly, make adjustments in a manner so that the castors will be raised approximately 5mm. from the floor and make sure that the machine position is level.

1. Install the machine in a suitable location.
2. Bring the leg adjusters to come into contact with the floor directly, make adjustments in a manner so that the castors will be raised approximately 5mm. from the floor and make sure that the machine position is level.
3. After making adjustments, fasten the leg adjuster nut upward and secure the height of the leg adjuster.

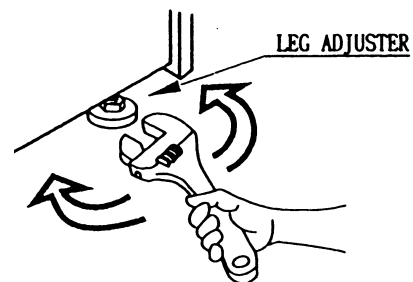
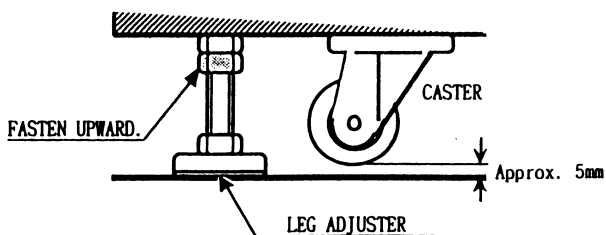
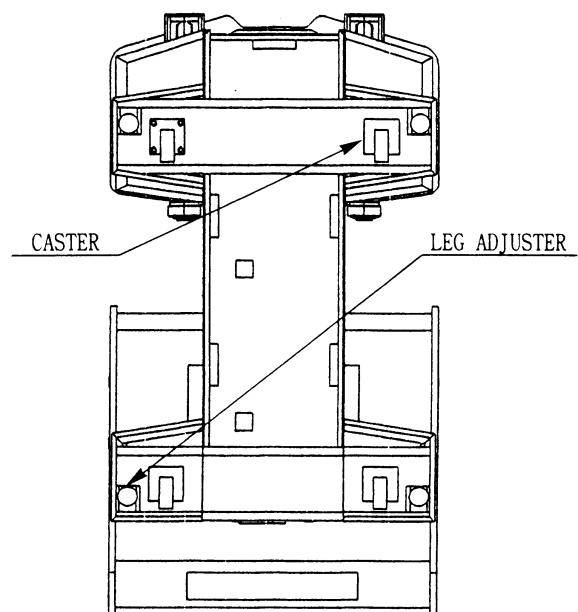

6.2. POWER SUPPLY, AND EARTH CONNECTION



- Maintenance must only be carried out by **Qualified Service Personnel**. Ensure that the mains power is switch OFF and disconnected before attempting any work.

The Transformer fitted to this machine is capable of accepting a wide range of voltages from 210V to 240V. This is factory set to 230V and, in normal operating conditions, should not need to be changed.

However circumstances may arise that require the primary voltage to be changed, to do this follow the procedure detailed below. **DO NOT REMOVE ANY WIRES ATTACHED TO THE TRANSFORMER.**

1. Switch off the machine and remove the IEC plug from the IEC inlet.
2. Unlock the L/H/S door, remove the two tamper-proof screws and remove the back door.
3. Disconnect Wire Harness Transformer In (HDF-66016UK) from the 6-way Mate 'n' Lok connector on the transformer primary.
4. Using Amp extraction tool No. 458994-1 or 876047-1 (not supplied), extract the pin located in position 4 on HDF-66016UK and insert into:

Position 2 for 210V input;

Position 3 for 220V input;

Position 4 for 230V input;

Position 5 for 240V input;

DO NOT REMOVE ANY WIRES ATTACHED TO THE TRANSFORMER

5. Plug HDF-66016UK back into the primary of the transformer.

6.3. CONNECTION TO THE POWER SUPPLY



- This operation may only be carried out once the machine has been completely assembled.

1. The AC Unit is located on the rear of the machine.
2. The AC Unit incorporates the mains input, fuse and mains switch.

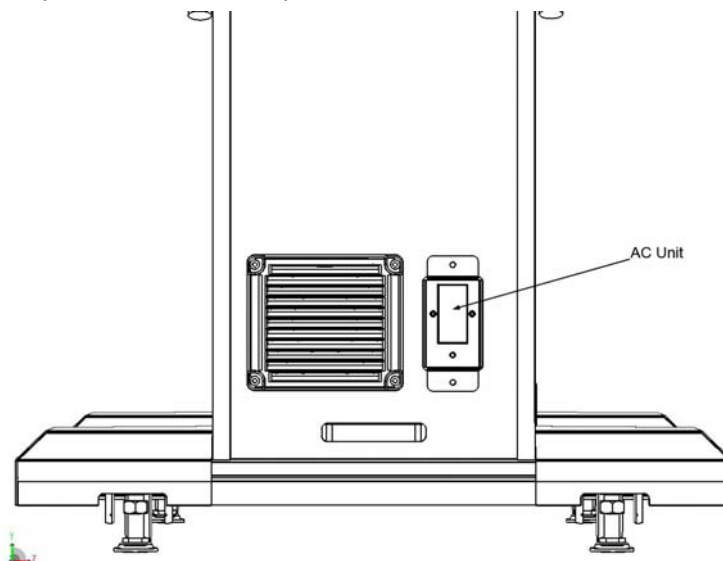

3. Ensure the mains switch is in the OFF position.
4. Insert the plug end of the eurolead into the mains input socket and switch to the ON position.
5. Connect the 13A moulded plug into the wall socket and switch on.

6.4. MACHINE CHECK



- This operation should only be carried out by QUALIFIED SERVICE PERSONNEL.

In the TEST MODE, ensure that the ASSEMBLY has been assembled correctly and that the CPU is in working order. In the TEST MODE perform the following tests.

The JVS TEST screen displays information on the connected JVS I/O boards. Select INPUT TEST to display input data for the currently displayed JVS I/O board. (See “c-1 JVS INPUT TEST”)

Select NEXT NODE to display information on the next NODE. If no JVS I/O boards are connected, the message “NO JVS NODE” will be displayed.

```
JVS TEST

INPUT TEST
NEXT NODE
->EXIT
NODE          1/3
NAME          SEGA ENTERPRISES, LTD.
              I/O BD JVS
              837-13551
              Ver1.00

CMD VER       1.1
JVS VER       2.0
COM VER       1.0
SWITCH        2 PLAYER(S) 13 BITS
COIN          2 SLOT(S)
ANALOG        8 CH
ROTARY        0 CH
KEYCODE       0
SCREEN        X: 0 Y: 0 CH: 0
CARD          0 SLOT(S)
HOPPER OUT    0 CH
DRIVER OUT    6 CH
ANALOG OUT    0 CH
CHARACTER     CHARA: 0 LINE: 0
BACKUP        0

SELECT WITH SERVICE AND PRESS TEST
```

The following information is displayed on this screen.

- NODE: The currently displayed NODE number and the total number of nodes.
- NAME: ID Code
- CMD VER: Command format version
- JVS VER: JVS standard version
- COM VER: Communication version
- SWITCH: Number of players and number of 1P switches
- COIN: Number of coin slots
- ANALOG: Number of analog channels
- ROTARY: Number of encoders
- KEYCODE: Keycode input active/inactive
- SCREEN: Screen position input (X axis, Y axis, number of channels)
- CARD: Number of card slots
- HOPPER OUT: Number of hoppers
- DRIVER OUT: Number of standard output drivers
- ANALOG OUT: Number of analog output channels
- CHARACTER: Number of characters/lines displayed
- BACKUP: Backup present/absent

Move the cursor to EXIT and press the TEST Button to return to the System Test Menu screen.

MONITOR TEST

Use MONITOR TEST to check the output of the monitor.

Enter MONITOR TEST and the following color bars will be displayed.

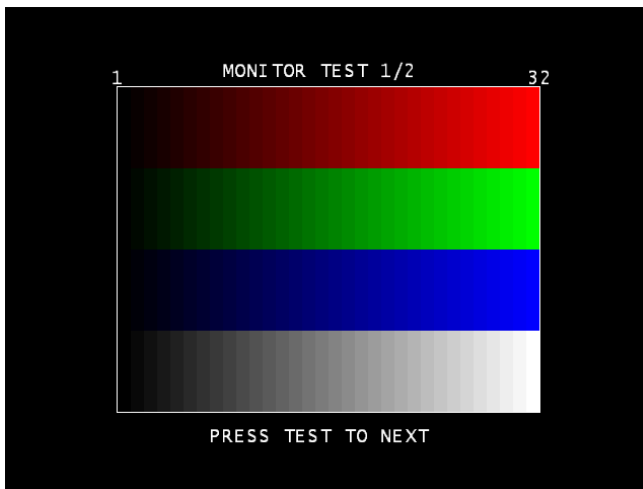

Press the TEST Button and the screen will change to the following crosshatch screen.

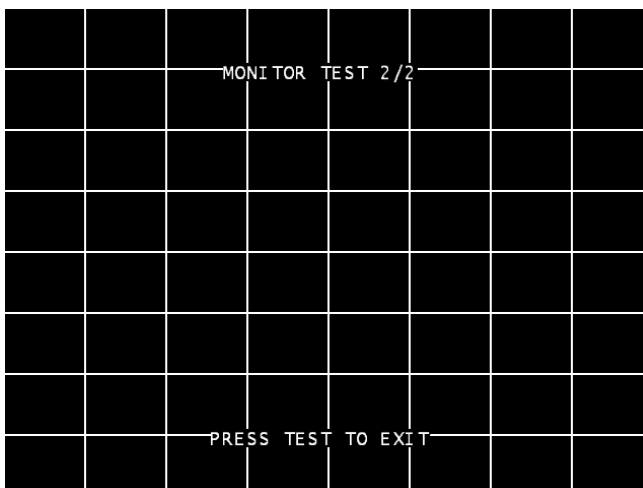

Press the TEST Button to return to the System Test Menu screen.

a. INPUT TEST

Select INPUT TEST to display the following screen and check the status of input devices. This test should be used periodically to check that each input device is functioning correctly.

INPUT TEST		
	PLAYER1	PLAYER2
START	OFF	OFF
GUN TRIGGER	OFF	OFF
GUN BUTTON	OFF	OFF
GUN SPEED X	7f	7f
GUN SPEED Y	7f	7f
GUN X	00	00
GUN Y	00	00
SCREEN IN	OUT	OUT
SERVICE		OFF
TEST		OFF
PRESS TEST AND SERVICE TO EXIT		

The items refer to the following input devices. Input is normal if the display to the right of each item changes from OFF to ON when each input device is operated.

Everything is functioning correctly if the GUN SPEED X and GUN SPEED Y values change according to the speed at which the Control Unit (Gun) is moved vertically/horizontally.

Everything is functioning correctly if the word "OUT" to the right of SCREEN IN changes to "IN" when the gun is pointed at the screen, and the values to the right of GUN X and GUN Y move between 00 to FF.

- START: The player START Buttons.
- GUN TRIGGER: The trigger on the gun.
- GUN BUTTON: The Button on the gun.
- GUN SPEED X: This value changes if gun is shaken on the X axis.
- GUN SPEED Y: This value changes if gun is shaken on the Y axis.
- GUN X: The X axis position on the screen targeted by the gun.
- GUN Y: The Y axis position on the screen targeted by the gun.
- SCREEN IN: Displays if the gun is pointing IN or OUT of the screen.
- SERVICE: The SERVICE Button.
- TEST: The TEST Button.

Press the SERVICE and TEST Buttons simultaneously to return to the Game Test Mode screen.

b. OUTPUT TEST

Select OUTPUT TEST to display the following screen and check the status of output devices. This test should be used periodically to check that the lamps are functioning correctly.

Use the SERVICE Button to move the cursor to the desired test item. Press the TEST Button to enter the selected item's test.



- Display of GUN MOTOR1 and GUN MOTOR2 options can be turned on or off using the DIP-SW. For cabinets with vibration motors attached to the Control Units (Guns), turn on display of the GUN MOTOR1 and GUN MOTOR2 under DIP-SW settings to alter these settings.

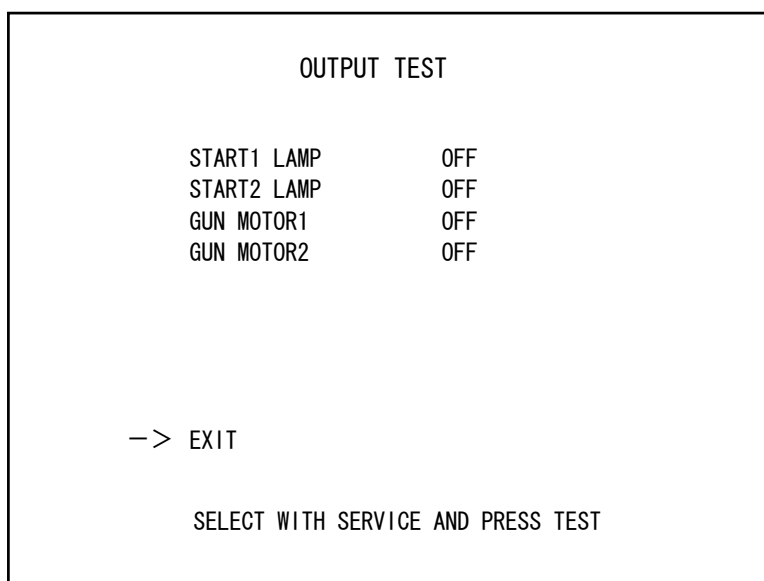

Perform the tests as follows.

- **START1 LAMP:** Select START1 LAMP and press the TEST Button to turn the option ON. The player 1 START Button will light up. The lamp will remain on for as long as the TEST Button is held down.
- **START2 LAMP:** Select START2LAMP and press the TEST Button to turn the option ON. The player 2 START Button will light up. The lamp will remain on for as long as the TEST Button is held down.
- **GUN MOTOR1:** Select GUN MOTOR1 and press the TEST Button to turn the option ON. The player 1 gun will begin to vibrate. The vibration will continue for as long as the TEST Button is held down.
- **GUN MOTOR2:** Select GUN MOTOR2 and press the TEST Button to turn the option ON. The player 2 gun will begin to vibrate. The vibration will continue for as long as the TEST Button is held down.

Move the cursor to EXIT and press the TEST Button to return to the Game Test Mode screen.

c. PLAYER1 GUN ADJUSTMENT/PLAYER2 GUN ADJUSTMENT

This item adjusts the Player 1 gun sight. (This is the same for “PLAYER2 GUN ADJUSTMENT”.)

Select PLAYER1 GUN ADJUSTMENT on the Gun Calibration Setting screen and press the TEST Button.

NOTE: “PLEASE SHOOT GRID WITH PLAYER1 GUN” on the screen will flash.

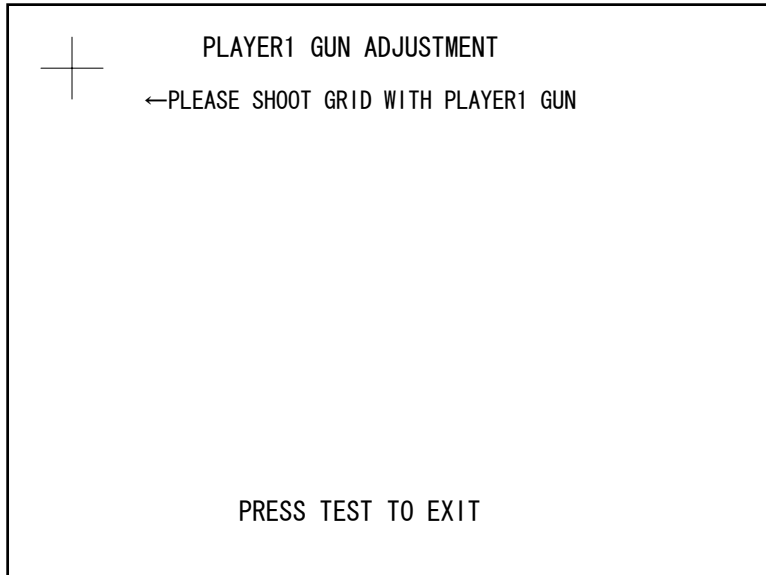

Follow the on-screen instructions to adjust the gun sight settings. Aim at the mark in the upper left corner and fire. The mark in the upper left will disappear, and the same mark will be displayed in the lower right corner.

(Press the TEST Button to return to the Gun Calibration Setting screen.)

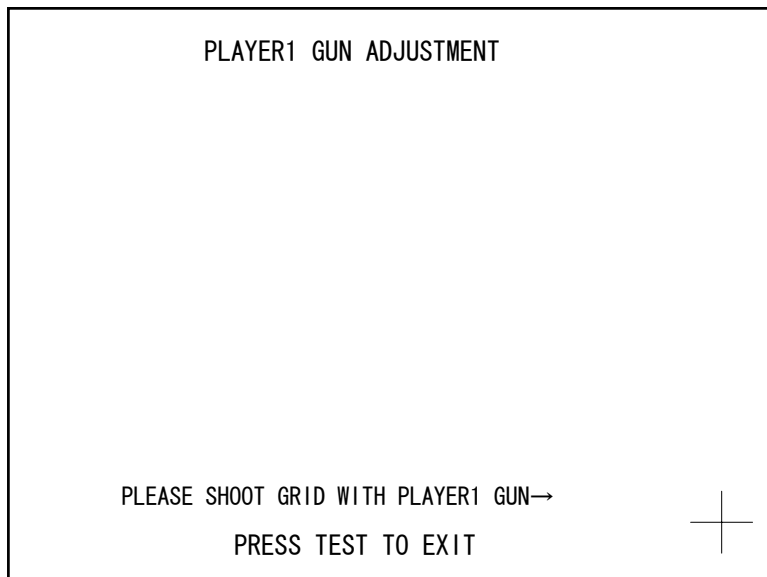

Aim and fire at the mark to the lower right. The mark to the lower right will disappear, and the same mark will be displayed in the center.
(Press the TEST Button to return to the Gun Calibration Setting screen.)

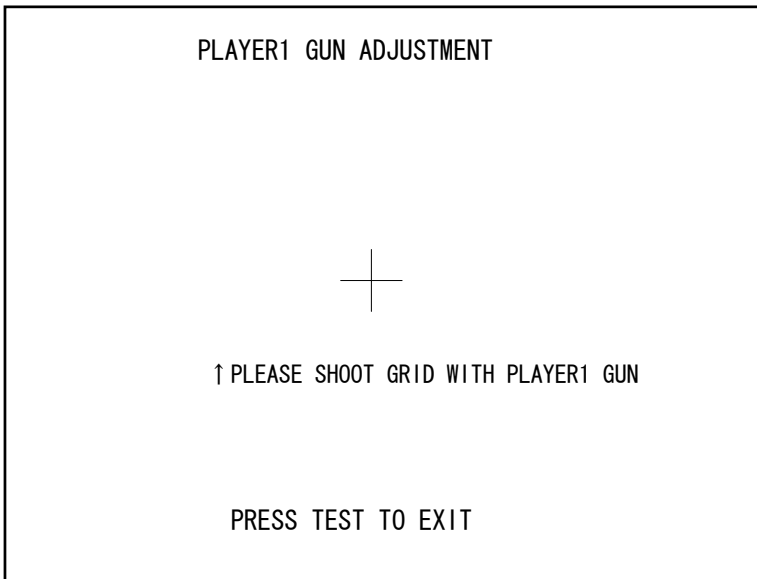

Aim and fire at the mark in the center.

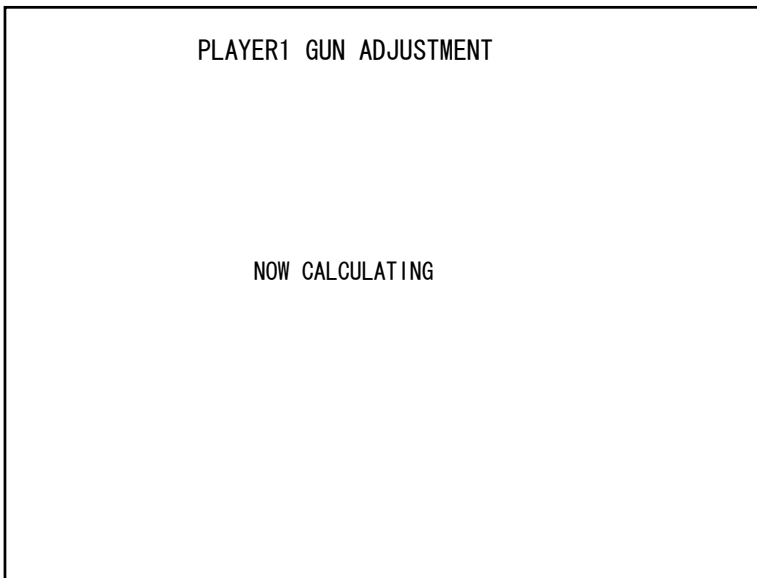

“NOW CALCULATING” will be displayed in the center. The screen will automatically switch to the following.

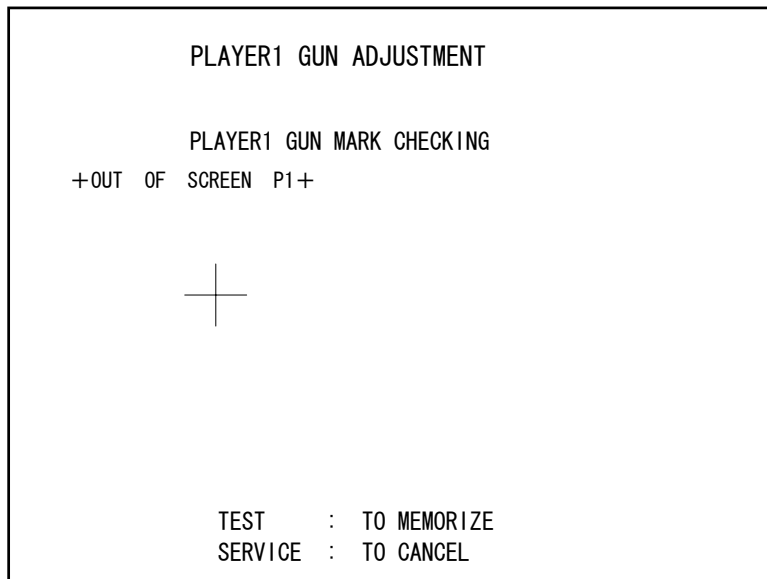

Point the Control Unit (Gun) at the screen and a gun mark will be displayed. Check to make sure that the gun can aim right up to the edges of the frame.

If the calibration is correct press the TEST Button to save it.

If re-calibration is required press the SERVICE Button. The calibration results will not be saved and you will return to the Gun Calibration Setting screen.

“OUT OF SCREEN” is displayed when the gun cross is perceived to be out of screen.

Refer to the following procedure when adjusting the sights.

Line up the concave sight nearest you on the gun so that it is at the height of the horizontal line of the “+” mark.

Line up the convex sight at the tip of the gun so that it also lines up with the horizontal line.

Line up the centers of the tops of the concave and convex sights with the center of the “+” and fire.

Perform the above inspections also at the time of monthly inspection.

7. PRECAUTIONS TO BE TAKEN WHEN MOVING THE MACHINE



- When moving the machine, be sure to pull out the plug from the power supply. Moving the machine with the plug as is inserted can cause the power cord to be damaged, resulting in a fire and or electric shock.
- When moving the machine on the floor, retract the leg adjusters and ensure that casters make contact with the floor. During transportation, pay careful attention so that casters do not tread power cords and earth wires. Damaging the power cords can cause an electric shock and or short circuit.
- When moving the machine, do not push the cabinet from the left/right direction. Pushing the cabinet from the left/right direction can cause the cabinet to fall down, resulting in injury and or parts damage.
- Do not attempt to complete this work alone, a minimum of 2 people are required.

When lifting or inclining the machine do not hold the controller (Gun) portion. Holding the controller portion can cause the controller and installation portion to be damaged due to the heavy weight.



8. OPERATION

For the safe operation of the product, be sure to comply with the following precautions.

PRECAUTIONS TO BE HEEDED FOR OPERATION



- Check if all of the leg adjusters are in contact with the surface. If they are not, the cabinet can move, causing an accident.
- Do not put any heavy item on this product. Placing any heavy item on the product may cause an accident or parts damage.
- Do not climb on the product. To check the top portion of the product, use a step ladder.



- To avoid accidents, be sure to provide sufficient space for operation by considering the most crowded situation. Insufficient operation space can cause customers to come into contact with and hit each other resulting in injury and trouble.

PAYING ATTENTION TO CUSTOMERS

To avoid injury and trouble, be sure to constantly give careful attention to the behaviour and manner of the visitors and players.



- To avoid electric shock and short circuit, do not allow customers to put hands and fingers or extraneous matter in the openings of the product or small openings in or around the doors.
- To avoid falling down and injury resulting from falling down, immediately stop the customer's leaning against or climbing on the product, etc.
- To avoid electric shock and short circuit, do not allow the customers to unplug the power plug.
- To avoid injury resulting from falling down, and electric shock due to spilled drinks, instruct the player not to place heavy items or drinks on the product.



- Immediately stop such violent acts as hitting and kicking the product. Such violent acts can cause parts damage or parts falling down, resulting in injury due to fragments and parts falling down.

8.1. TROUBLESHOOTING



- These procedures should only be carried out by QUALIFIED SERVICE PERSONNEL.

If a problem occurs, first check the wiring connections.

PROBLEMS	CAUSE	COUNTERMEASURES
When the main switch is turned ON, the machine is not activated	The power is not ON.	Firmly insert the plug into the outlet.
	Incorrect power source/voltage.	Make sure that the power supply/voltage are correct.
	AC Unit CIRCUIT PROTECTION DEVICE (i.e.; fuse) was activated due to an instantaneous over current.	First, remove the cause of over current and reinstate the circuit protection device to its original status. Then identify the cause of the fault on the item which caused the over current & fix.
The colour image on The screen is incorrect	Incorrect monitor adjustment.	Make appropriate adjustments. Refer to the display service manual.
The on-screen image of the monitor sways and/or shrinks	The power source and voltage are not correct.	Make sure that the power supply and voltage are correct.
Sound is not emitted	Sound volume adjustment is not correct.	Adjust the volume setting on the display. Refer to the display service manual
The fluorescent lamp does not light up	Fluorescent lamp needs replacement	Replace the fluorescent lamp
	The connector is disconnected	Check connector connections in the billboard case.
The LEADER lamp does not light up	The lamp needs replacement.	Replace the lamp.

9. HOW TO PLAY

The following explanations apply to the product when functioning properly. If the product operates differently from the following contents, a fault may have occurred. Immediately look into and eliminate the cause of the fault to ensure proper operation.

The fluorescent light in the billboard and the cold-cathode tube in the lighting unit are always on whenever the power is turned on. Demo movies and game rankings are displayed on the screen. Audio may also be played from speakers on the left and right sides of the main cabinet. However, it is possible to select whether sound is output or not during Attract Mode through Test Mode settings.

Both the right and left START buttons are integrated with a light. The light flashes when sufficient coins are inserted for play. The light goes out when the START button is pressed to start the game.

- 1) Fluorescent lamps are lit.
- 2) On-screen images are displayed.
- 3) Sound is emitted.
- 4) START BUTTON flashes when coins inserted.



9.1. GAME OUTLINE

- Insert a coin and a credit will be added to the credit indicator below the screen. When enough coins have been entered for one play, the “INSERT COIN(S)” message below the screen will change to “PRESS START BUTTON,” and both START buttons will flash.
- *NOTE: The maximum number of credits that can be counted at once is “24.” Any coins inserted after 24 credits have been counted will not be counted as credits, nor will they be refunded. However, they will be counted as inserted coins on the data display and by the coin meter.*
- A player plays on the left (Player 1) or the right (Player 2) by pressing the START button on that side. Pressing the START button begins the game.
- When the game starts, a demo plays and the stage title is displayed before switching over to game play.
 - Life, loaded bullets remaining and grenades are shown at the bottom left of the screen for the player on the left (Player 1). Life, loaded bullets remaining and grenades are shown at the bottom right of the screen for the player on the right (Player 2).



- 1) Each bullet represents one remaining shot.
- 2) The number of grenades that can currently be used.
- 3) Life is displayed as a flame mark. The game ends when life runs out.
- 4) Credit indicator.

The gun holds 30 shots. When empty, the message “RELOAD” will appear on the screen. The player can reload the gun by gently shaking it or by pointing it outside of the screen. The gun can be reloaded by gently shaking it or pointing it outside of the screen even if bullets remain in the gun.

Only the displayed number of grenades may be used. This number may be increase by collecting grenades during each stage. A maximum of 5 grenades may be held at once. Also, if only 2 or less grenades remain upon clearing a stage, the player will automatically start the next stage with 3 grenades.

(1) RELOAD!

Shake the gun controller to reload!
Release the trigger when reloading!

(2) GRENADE!

Press this button to throw a grenade!

(3) RAPID FIRE!

Hold down the trigger to spray bullets!
Players can defend themselves against oil drums, and axes thrown by enemies by shooting them.

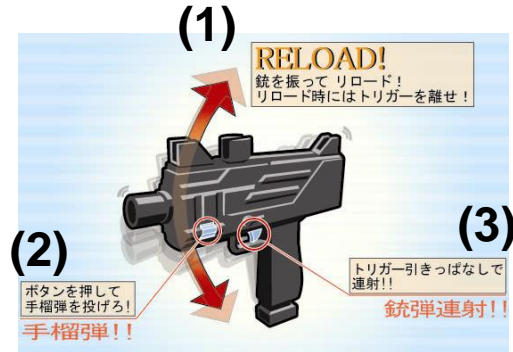

rocks

Shooting the background will sometimes cause items to appear. Players grab them by shooting them. Grabbing items will increase a player’s score or restore life.

When life reaches zero the game ends.

A unique boss awaits the players at each stage. The bosses appear different on each stage. Players defeat a boss by reducing its Life Meter to zero.

In addition, when a boss begins to attack the Cancel Meter appears. Players can stop the boss’s attack by reducing this meter to zero.

This is the boss’s cancel meter.
Stop the boss’s attack by reducing it to zero.



This is the boss’s life meter.
Defeat the boss by reducing it to zero.

Boss

As the game progresses, players will be faced with enemies grabbing them and attempting to push them over. To survive this danger, the player must shake the gun controller to fill up the on-screen meter within the time limit. If the player fails to do so they will take damage, reducing their number of lives, and risk being pushed over and taking further damage.



- 1) Shaking the gun controller fills up the on-screen meter.
- 2) Filling the meter up within the time limit will shake the enemy off.
- 3) Being grabbed by an enemy.
- 4) The gun cannot be fired and grenades cannot be used when grabbing an enemy.

- A player can join a game in progress at any time by inserting coins and pressing the START button. In addition, the START button on the side where no one is playing will continue to flash if enough credits remain. A second player can join the game by pressing the flashing START button.
- "CONTINUE" is displayed when life drops to zero. A player may continue by inserting sufficient coins and pressing the START button.
- If upon clearing every stage in the game the player's score is better than the current top 10, they may enter their name.

9.2. ITEMS

Other items can also be found during the game.



“Medical Kit”
Increases life by one.

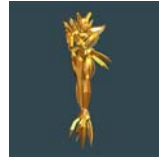

“Mini Magician”
Increases a player’s score.



“Gold Coin”
Increases a player’s score.



“Golden Frog”
Increases a player’s score.



“Silk Hat”
Increases a player’s score.



“Toy’s Bus”
Increases a player’s score.

9.3. *PLAY HINTS*

- **Aim for the head!**

Enemies in every stage, aside from boss characters, will lose the most life when shot in the head. Therefore, shooting enemies accurately in the head is the fastest way to defeat them.

- **Choose your favorite route!**

Each stage has a number of branching paths. Some branching paths can be simply chosen and some depend upon certain actions. The key to improving play is to find the route that suits you best!

- **Use recovery items to regain lost lives!**

Although being attacked by enemies will reduce your remaining lives, each stage also contains items that will increase remaining lives. Also, upon clearing a stage your performance may award extra lives. Repeated play and knowledge of the levels will aid in gathering extra lives.

- **Use grenades effectively!**

As well as the gun, you have grenades in your arsenal. These can cause massive damage to enemies, and are best used when there are a large number of enemies on screen or at sections you find difficult. Your number of remaining grenades can be increased by collecting items, and if a stage is cleared with less than 2 grenades remaining you will start the next stage with 3.

- **Aim for the boss' weak spot!**

Every stage boss has a weak spot. Shooting this weak spot accurately will help you to avoid boss' attacks. However, practice will be required to hit the weak spot accurately whilst the boss is moving.

10. MAINTENANCE INSTRUCTIONS

10.1. EXPLANATION OF TEST AND DATA DISPLAY

Use the switches on the VTS to enter the TEST MODE. This will allow you to carry out post installation and periodic checks and adjustments. The following section details the function of each of the tests:



- Be very careful about entering TEST MODE. If the machine you wish to test is linked to other machines, exiting test on your machine will cause a network check to be carried out. This will disable all other machines linked to it.

ITEM	DESCRIPTION	INTERVAL
INSTALLATION OF THE MACHINE	<p>When the machine is installed perform the following checks:</p> <ul style="list-style-type: none"> • Check to see that each setting is as per the standard settings input at the time of shipment. • In the INPUT TEST mode, check each switch and V.R. • In the OUTPUT TEST mode, check each of the lamps. • In the MEMORY TEST mode check all of the IC's on the IC BD. 	Monthly
MEMORY	<ul style="list-style-type: none"> • On the TEST MENU screen choosing the MEMORY TEST allows self-test to be performed. In this test RAM & ROM are tested. 	Monthly
PERIODIC CHECKS	<p>Periodically perform the following</p> <ul style="list-style-type: none"> • MEMORY TEST. • Ascertain each setting. • In the INPUT TEST mode, test the control devices. • In the OUTPUT TEST mode, check each of the lamps. 	Monthly
CONTROL SYSTEM	<ul style="list-style-type: none"> • In the INPUT TEST mode, check each switch and V.R. • Adjust or replace each switch and V.R. 	Monthly
MONITOR	<ul style="list-style-type: none"> • In the C.R.T. TEST mode, check to ensure the monitor is adjusted correctly • Clean screen (switch off machine and remove the plug) 	Monthly Weekly
IC BOARD	<p>MEMORY TEST</p> <ul style="list-style-type: none"> • In the SOUND TEST mode, check the sound related ROMs 	Monthly
DATA CHECK	<ul style="list-style-type: none"> • Check such data as held in the bookkeeping screens, relating to number and length of plays 	Monthly
EXTERIOR MAINTENANCE	<ul style="list-style-type: none"> • Clean surfaces • Lubricate seat sliders <p>Note: This appliance shall not be cleaned by a water jet.</p>	Monthly
COIN MECHANISM	<ul style="list-style-type: none"> • Check switch operation (if fitted) 	Monthly

10.1.1.VTS ASSEMBLY



- Do not touch places other than those specified. Touching places not specified could cause an electric shock or short circuit.

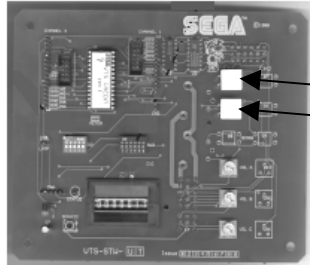

TEST BUTTON
SERVICE BUTTON

Opening the Coin Chute door will reveal the VTS Assembly shown above. The function of each switch is as follows. The controls on the left affect the 1P cockpit, those on the right the 2P.

TEST BUTTON
(TEST SW)

Used to enter TEST mode. Also has function during TEST mode. Refer to the later section detailing TEST mode.

SERVICE BUTTON
(SERVICE SW)

Gives credits without registering on the coin counter. Also used during TEST mode.

DEMAG <OPTIONAL>

Used to DEMAG the CRT

VOLUME CONTROL FRONT

Adjusts the sound output from the front speakers.

VOLUME CONTROL REAR <OPTIONAL>

NOT USED

The control panel switches can also be used in the place of the VTS switches:



PLAYER 1 BUTTON can represent the TEST BUTTON within the TEST MODE only.

PLAYER 2 BUTTON can represent the SERVICE BUTTON within the TEST MODE only.

10.1.2.SYSTEM TEST MODE

System Test Mode can be used to check the information or the operation of the LINDBERGH board, adjust Monitor colour, and perform coin/credit settings.



- When setting changes are made within TEST MODE, be sure to exit from TEST MODE using the exit options. If you turn the power off and then on without having exited correctly the changes you made will not take effect.



- Make sure that the control panel support is fixed firmly in place before performing any operations. Closing the control panel with the support loose may lead to accidents.
- Be careful not to trap your fingers when closing the control panel.



- The details of changes to Test Mode settings are saved when you exit from Test Mode by selecting EXIT from the SYSTEM TEST MENU. Be careful because if the power is turned off before that point, changes to the settings will be lost.
- Use with the specified settings. If settings other than those specified are used, inappropriate operations or malfunction may occur.

Press the TEST Button after powering on the unit to display the following SYSTEM TEST MENU.

SYSTEM TEST MENU	
SYSTEM INFORMATION a
STORAGE INFORMATION b
JVS TEST c
MONITOR TEST d
SPEAKER TEST e
COIN ASSIGNMENTS f
CLOCK SETTING g
NETWORK SETTING h
GAME TEST MODE i
-> EXIT	
SELECT WITH SERVICE AND PRESS TEST	

Use the SERVICE Button to move the cursor to the desired test item. Press the TEST Button to enter the selected item.

Press the TEST Button when GAME TEST MODE is selected to change to the Test Menu specific to this game.

Refer to the section “9-3 GAME TEST MODE.”

After the test is complete, move the cursor to EXIT and press the TEST Button to return to the Game Advertisement screen.

a. SYSTEM INFORMATION

The SYSTEM INFORMATION screen displays system information.

```
SYSTEM INFORMATION

MOTHER BOARD
SERIAL NO.      AAGE-01A00394715
KERNEL VERSION  2.4.20_mv131
BOOT VERSION    1.00(BUILD 0001)
REGION          JP
MEMORY SIZE     1008 MB
STORAGE DEVICE
STORAGE MODEL   HDS728040PLAT20
STORAGE SIZE    39266 MB
BASE BOARD
SERIAL NO.      A80E-01A00514715
FIRM VERSION    0.17
GRAPHIC BOARD
DEVICE ID       10de:0045

PRESS TEST TO EXIT
```

The following information is displayed on this screen.

- MOTHER BOARD
 - SERIAL NO.: The serial number of the game board.
 - KERNEL VERSION: The system's OS version.
 - BOOT VERSION: The boot program version.
 - REGION: The region setting.
 - MEMORY SIZE: The onboard memory size.

- STORAGE DEVICE:
 - STORAGE MODEL: (Displayed in the above photo but not actually displayed by the product)
 - STORAGE SIZE: The total capacity of the program installer device.

- BASE BOARD
 - SERIAL NO.: The serial number.
 - FIRM VERSION: The firmware version.

- GRAPHIC BOARD
 - DEVICE ID: The graphic board's ID.

Press the TEST Button to return to the System Test Menu screen.

b. STORAGE INFORMATION

The STORAGE INFORMATION screen displays information on the game contained within the program installer device. This screen is also used when uninstalling the game contained within the program installer device.

Until preparations to launch the game are complete, a “now checking” screen will be displayed and uninstall cannot be performed. If the program installer device does not contain any game data, the game information will be displayed in grey and uninstall cannot be performed.

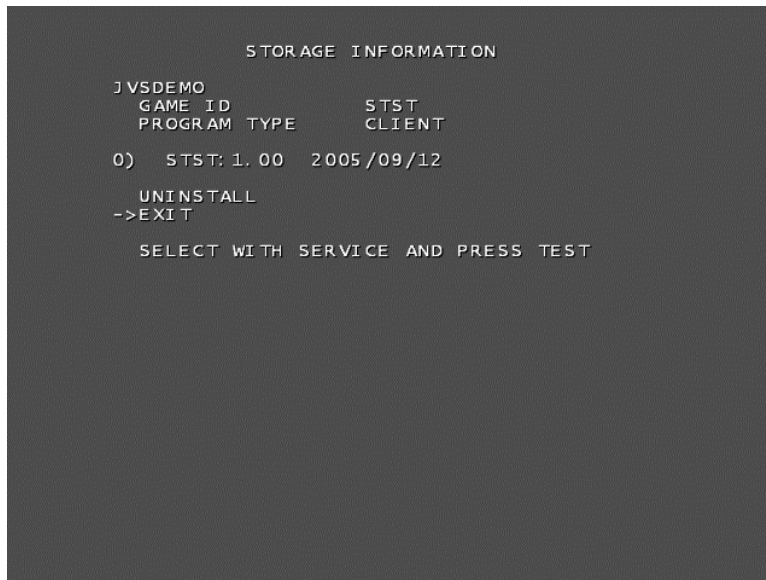

The following information is displayed on this screen.

- GAME TITLE
- GAME ID
- PROGRAM TYPE
- INSTALLED IMAGE LIST
 - IMAGE NUMBER
 - GAME ID
 - VERSION
 - DATE OF RELEASE

Move the cursor to EXIT and press the TEST Button to return to the System Test Menu screen.

c. JVS TEST

The JVS TEST screen displays information on the connected JVS I/O boards.

Select INPUT TEST to display input data for the currently displayed JVS I/O board. (See “d - JVS INPUT TEST”)

Select NEXT NODE to display information on the next NODE.

If no JVS I/O boards are connected, the message “NO JVS NODE” will be displayed.

```

                                JVS TEST

INPUT TEST
NEXT NODE
->EXIT
NODE                               1/3
NAME                               SEGA ENTERPRISES, LTD.
                                I/O BD JVS
                                837-13551
                                Ver1.00

CMD VER                             1.1
JVS VER                             2.0
COM VER                             1.0
SWI TCH                             2 PLAYER(S) 13 BITS
COIN                                 2 SLOT(S)
ANALOG                              8 CH
ROTARY                              0 CH
KEYCODE                              0
SCREEN                              X: 0 Y: 0 CH: 0
CARD                                 0 SLOT(S)
HOPPER OUT                          0 CH
DRIVER OUT                          6 CH
ANALOG OUT                          0 CH
CHARACTER                          CHARA: 0 LINE: 0
BACKUP                              0

SELECT WITH SERVICE AND PRESS TEST
```

The following information is displayed on this screen.

- NODE: The currently displayed NODE number and the total number of connected NODEs
- NAME: ID Code
- CMD VER: Command format version
- JVS VER: JVS standard version
- COM VER: Communication version
- SWITCH: Number of players and number of 1P switches
- COIN: Number of coin slots
- ANALOG: Number of analog channels
- ROTARY: Number of encoders
- KEYCODE: Keycode input active/inactive
- SCREEN: Screen position input (X axis, Y axis, number of channels)
- CARD: Number of card slots
- HOPPER OUT: Number of hoppers
- DRIVER OUT: Number of standard output drivers
- ANALOG OUT: Number of analog output channels
- CHARACTER: Number of characters/lines displayed
- BACKUP: Backup present/absent

Move the cursor to EXIT and press the TEST Button to return to the System Test Menu screen.

d. JVS INPUT TEST

Use the JVS INPUT TEST to test the JVS input.

The hexadecimal input information from the JVS I/O board will be displayed in real time.

```
                JVS TEST
                INPUT TEST

NODE           1/3

SYSTEM        00
PLAYER 1      0000
PLAYER 2      0000
COIN 1        0000
COIN 2        0000
ANALOG 0      8900
ANALOG 1      6800
ANALOG 2      8800
ANALOG 3      8400
ANALOG 4      BF00
ANALOG 5      A000
ANALOG 6      8600
ANALOG 7      7800

                PRESS TEST AND SERVICE TO EXIT
```

The following information is displayed on this screen.

- SYSTEM: System switch input data
- PLAYER: Player number and player switch input data
- COIN: Slot number and coin input data
- ANALOG: Channel number and analog input data
- ROTARY: Rotary number and rotary input data

Press the SERVICE and TEST Buttons simultaneously to return to the JVS Test screen.

e. MONITOR TEST

Use MONITOR TEST to check the output of the monitor.

Enter MONITOR TEST and the following color bars will be displayed.

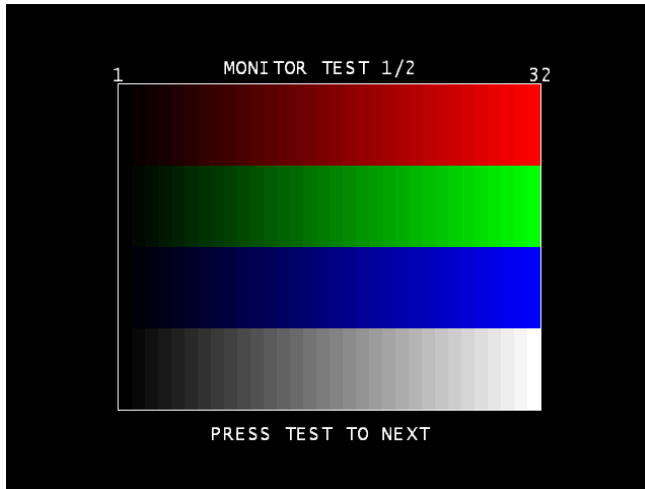

Press the TEST Button and the screen will change to the following crosshatch screen.

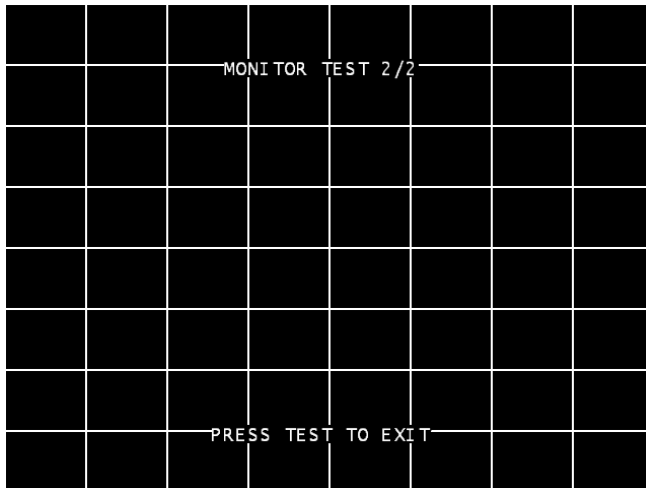

Press the TEST Button to return to the System Test Menu screen.

f. SPEAKER TEST

Use SPEAKER TEST to check the output of each speaker by having them each emit a test sound.

Select each speaker with the cursor and press the TEST Button to turn that speaker ON or OFF. When set to ON a test sound will be emitted from that speaker.

It is possible to set multiple speakers to emit the test sound at the same time.

If the stipulated sound card is not present this test screen will not display this menu.

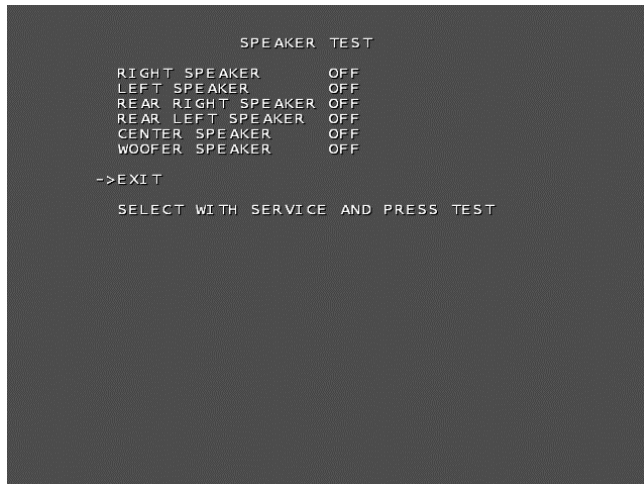

The speakers available to test are as follows.

- RIGHT SPEAKER
- LEFT SPEAKER
- REAR RIGHT SPEAKER
- REAR LEFT SPEAKER
- CENTER SPEAKER
- WOOFER SPEAKER

Move the cursor to EXIT and press the TEST Button to return to the System Test Menu screen.

g. COIN ASSIGNMENTS

Use COIN ASSIGNMENTS to alter the credit settings.

The game will award players the number of credits determined here. Settings will only be saved if they have been changed.

Changing the credit settings will also clear the current inserted coins value.

If no baseboard is present, this option will not appear on the main menu.

The following settings must be set as shown below for this product.

- COIN CHUTE TYPE: COMMON
- SERVICE TYPE: COMMON

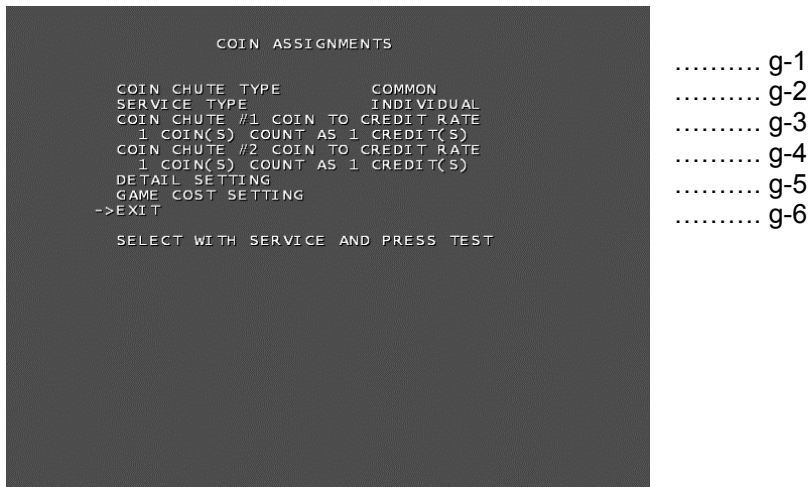

The following information is displayed on this screen.

g-1 COIN CHUTE TYPE

COMMON	Allow all credits to be used by all players.
INDIVIDUAL	Treat each player's credits individually.

g-2 SERVICE TYPE (Service Button Type)

COMMON	When the COIN CHUTE TYPE is set to COMMON, the number of credits available to all players will increase by 1.
	When the COIN CHUTE TYPE is set to INDIVIDUAL, each player's credits will increase by 1.
INDIVIDUAL	When the COIN CHUTE TYPE is set to COMMON, the number of credits available to all players will increase by 1.
	When the COIN CHUTE TYPE is set to INDIVIDUAL, the player corresponding to the SERVICE Button's credits will increase by 1.

g-3 COIN CHUTE #1 COIN TO CREDIT RATE (Coin and credit conversion rate 1)

1 COIN(S) COUNT AS 1 CREDIT(S)	1 coin counts as 1 credit
2 COIN(S) COUNT AS 1 CREDIT(S)	2 coins count as 1 credit
3 COIN(S) COUNT AS 1 CREDIT(S)	3 coins count as 1 credit
4 COIN(S) COUNT AS 1 CREDIT(S)	4 coins count as 1 credit
5 COIN(S) COUNT AS 1 CREDIT(S)	5 coins count as 1 credit
1 COIN(S) COUNT AS 2 CREDIT(S)	1 coin counts as 2 credits
1 COIN(S) COUNT AS 3 CREDIT(S)	1 coin counts as 3 credits
1 COIN(S) COUNT AS 4 CREDIT(S)	1 coin counts as 4 credits
1 COIN(S) COUNT AS 5 CREDIT(S)	1 coin counts as 5 credits
FREE PLAY	Free play (no coins required)
DETAIL SETTING	More detailed settings

g-4 COIN CHUTE #2 COIN TO CREDIT RATE (Coin and credit conversion rate 2)

(Can only be set when the COIN CHUTE TYPE is set to COMMON and the COIN setting for the COIN CHUTE #1 COIN TO CREDIT RATE is set to "1")

g-5 DETAIL SETTING

The COIN ASSIGNMENTS DETAIL SETTING screen allows more detailed settings that cannot be performed on the Coin Setting screen to be performed.

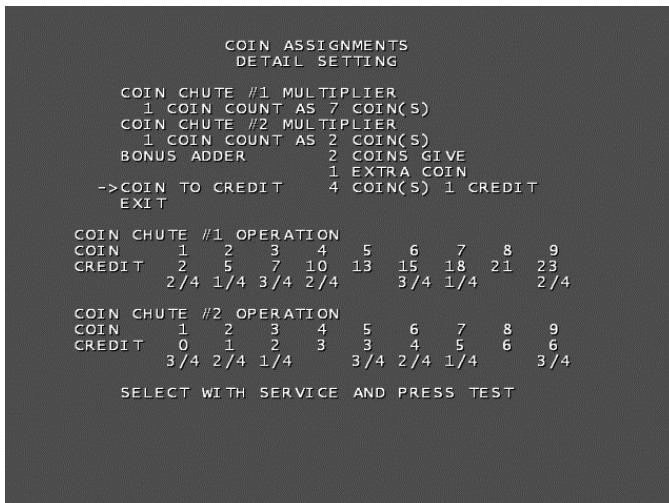

The following information is displayed on this screen.

- COIN CHUTE #1 MULTIPLIER: Coin conversion rate for #1 (How many coins 1 inserted coin counts for)
- COIN CHUTE #2 MULTIPLIER: Coin conversion rate for #2 (How many coins 1 inserted coin counts for)
- BONUS ADDER: Use of a bonus coin

NO BONUS ADDER	No bonus coin given
2 COINS GIVE 1 EXTRA COIN	2 coins inserted successively award 1 bonus coin
3 COINS GIVE 1 EXTRA COIN	3 coins inserted successively award 1 bonus coin
4 COINS GIVE 1 EXTRA COIN	4 coins inserted successively award 1 bonus coin
5 COINS GIVE 1 EXTRA COIN	5 coins inserted successively award 1 bonus coin
6 COINS GIVE 1 EXTRA COIN	6 coins inserted successively award 1 bonus coin
7 COINS GIVE 1 EXTRA COIN	7 coins inserted successively award 1 bonus coin
8 COINS GIVE 1 EXTRA COIN	8 coins inserted successively award 1 bonus coin
9 COINS GIVE 1 EXTRA COIN	9 coins inserted successively award 1 bonus coin

- COIN TO CREDIT: The number of coins to number of credits conversion rate.

Move the cursor to EXIT and press the TEST Button to return to the Coin Assignments screen.

g-6 GAME COST SETTING

Use the COIN ASSIGNMENTS GAME COST SETTING screen to set the cost (number of required credits) that the game program will use to determine if there are enough credits to play the game.

A total of 8 game costs can be defined. The game cost is defined by the BOOT ID, and when the second boot recognizes the game, the game cost defined by the BOOT ID will be displayed.

If the game is not recognized, the default game cost will be displayed.

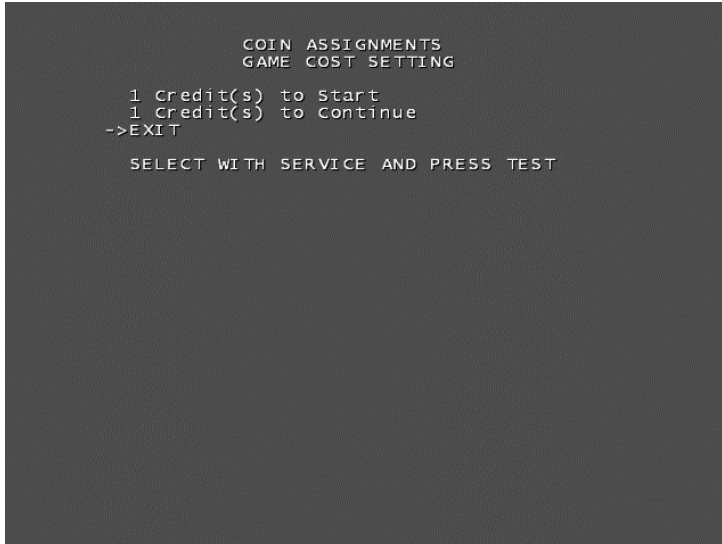

Move the cursor to EXIT and press the TEST Button to return to the Coin Assignments screen.

h. CLOCK SETTING

Use CLOCK SETTING to set the date and time.

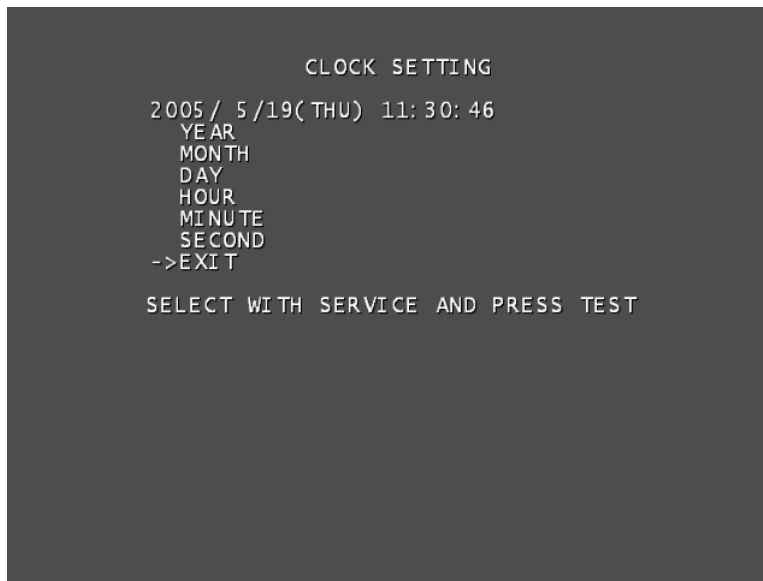

Use the SERVICE Button to move the cursor to the category that you wish to change and press the TEST Button to increase that value. Holding the TEST Button down will make the value continuously increase. Changes will come into effect when you exit.

Move the cursor to EXIT and press the TEST Button to return to the System Test Menu screen.

i. NETWORK SETTING

Use NETWORK SETTING to determine network settings or to test the network.

This product does not use the network function. You must use the following factory settings.

- NETWORK TYPE: MAIN
- MAIN NETWORK: No need to set.

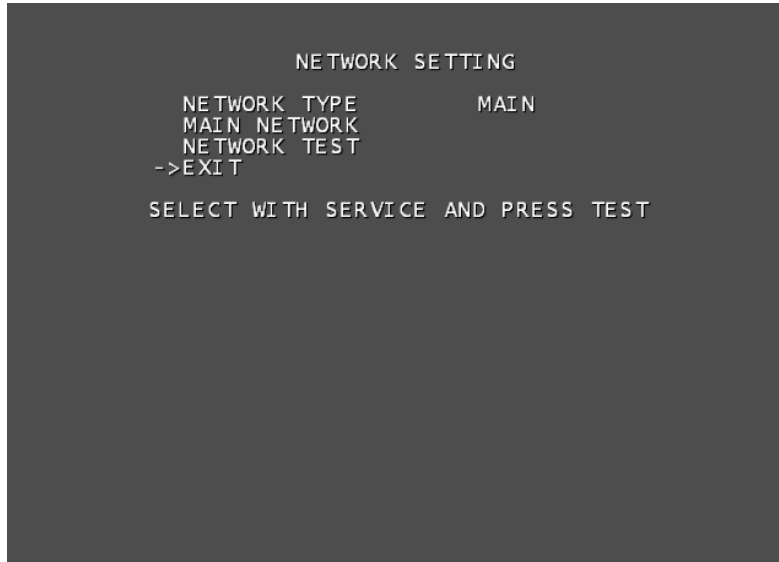

The following information is displayed on this screen.

- NETWORK TYPE: Sets the type of network to use.
- MAIN NETWORK: Sets the onboard LAN.
- NETWORK TEST: Performs a network test.

Move the cursor to EXIT and press the TEST Button to return to the System Test Menu screen.

Select a category on the NETWORK SETTING (Setting Menu) and the following screen will be displayed. However, since this product does not use network function, this manual does not contain instructions for performing network settings or tests.

```
NETWORK SETTING
DHCP          DISABLE
IP ADDRESS   192.168.0.30
SUBNET MASK   255.255.255.0
GATEWAY       0.0.0.0
PRIMARY DNS   0.0.0.0
SECONDARY DNS 0.0.0.0
->EXIT
SELECT WITH SERVICE AND PRESS TEST
```

NETWORK SETTING Screen

```
NETWORK TEST
STATUS       BAD
CHECKING     100%
DHCP ----- BAD
LOOPBACK --- GOOD
GATEWAY --- GOOD
SERVER ---- BAD
PRESS TEST TO EXIT
```

NETWORK TEST Screen

j. GAME TEST MODE

Opens the Game Test Mode, allowing game specific settings and tests to be performed.

After starting the game, this option will be displayed in grey until preparations are complete. Select the Game Test Mode option then select EXIT to begin the game test.

10.1.3.GAME TEST MODE



• When setting changes are made within TEST MODE, be sure to exit from TEST MODE using the exit options. If you turn the power off and then on without having exited correctly the changes you made will not take effect.

Game Test Mode allows game settings to be altered, Control Units (Guns) to be calibrated and game data to be checked.

Select GAME TEST MODE from the System Test Menu screen to display the Game Test Mode screen as follows.

Use the SERVICE Button to move the cursor to the desired test item. Press the TEST Button to enter the selected item's test.

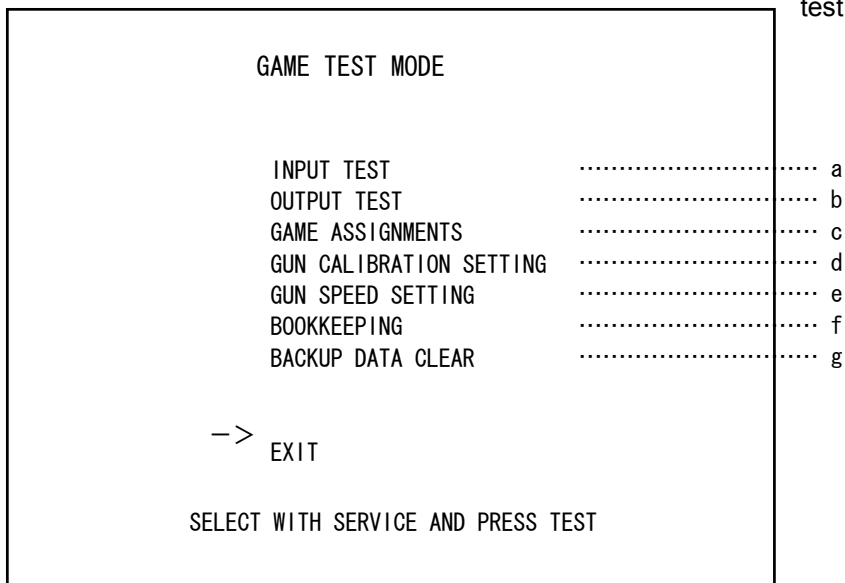

Performs test, adjustments and settings for each of the Game Test Mode screen items below.

- | | |
|-----------------------------|---|
| a. INPUT TEST: | Tests each input device used in the game. |
| b. OUTPUT TEST: | Tests each output device used in the game. |
| c. GAME ASSIGNMENTS: | Adjusts game settings. |
| d. GUN CALIBRATION SETTING: | Performs sight settings for the game's gun. |
| e. GUN SPEED SETTING: | Sets the speed volume for the game's gun. |
| f. BOOKKEEPING: | View all recorded game data. |
| g. BACKUP DATA CLEAR: | Erase all game records. |

After selecting an item, read the explanations below regarding operation.

After performing tests and adjustments, return to the Game Test Mode screen, select EXIT and press the TEST Button. You will return to the System Test Menu screen.

Move the cursor to EXIT on System Test Menu screen and press the TEST Button to return to the Game Play screen.

a. INPUT TEST

Select INPUT TEST to display the following screen and check the status of input devices. This test should be used periodically to check that each input device is functioning correctly.

INPUT TEST		
	PLAYER1	PLAYER2
START	OFF	OFF
GUN TRIGGER	OFF	OFF
GUN BUTTON	OFF	OFF
GUN SPEED X	7f	7f
GUN SPEED Y	7f	7f
GUN X	00	00
GUN Y	00	00
SCREEN IN	OUT	OUT
SERVICE		OFF
TEST		OFF

PRESS TEST AND SERVICE TO EXIT

The items refer to the following input devices. Input is normal if the display to the right of each item changes from OFF to ON when each input device is operated.

Everything is functioning correctly if the GUN SPEED X and GUN SPEED Y values change according to the speed at which the Control Unit (Gun) is moved vertically/horizontally.

Everything is functioning correctly if the word "OUT" to the right of SCREEN IN changes to "IN" when the gun is pointed at the screen, and the values to the right of GUN X and GUN Y move between 00 to FF.

- START: The player START Buttons.
- GUN TRIGGER: The trigger on the gun.
- GUN BUTTON: The Button on the gun.
- GUN SPEED X: This value changes if gun is shaken on the X axis.
- GUN SPEED Y: This value changes if gun is shaken on the Y axis.
- GUN X: The X axis position on the screen targeted by the gun.
- GUN Y: The Y axis position on the screen targeted by the gun.
- SCREEN IN: Displays if the gun is pointing IN or OUT of the screen.
- SERVICE: The SERVICE Button.
- TEST: The TEST Button.

Press the SERVICE and TEST Buttons simultaneously to return to the Game Test Mode screen.

b. OUTPUT TEST

Select OUTPUT TEST to display the following screen and check the status of output devices. This test should be used periodically to check that the lamps are functioning correctly.

Use the SERVICE Button to move the cursor to the desired test item. Press the TEST Button to enter the selected item's test.

[For Overseas Other than Europe]

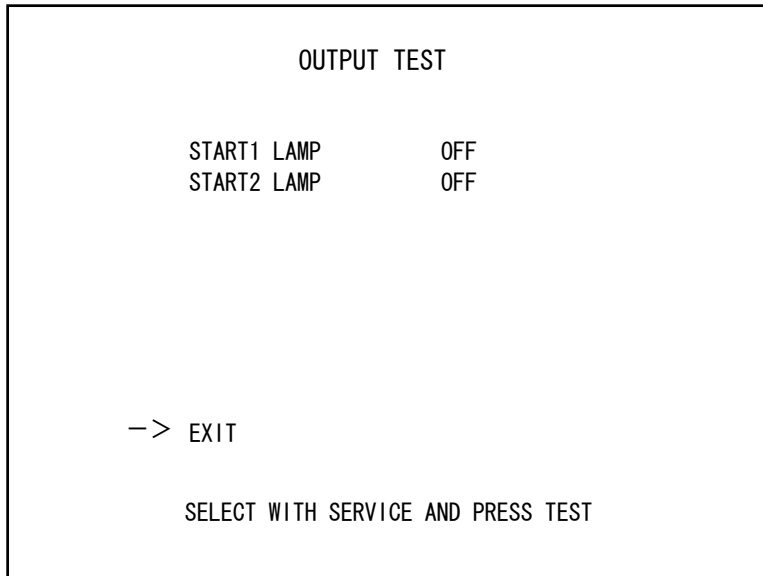

Perform the tests as follows.

● **START1 LAMP:** Select START1 LAMP and press the TEST Button to turn the option ON. The player 1 START Button will light up. The lamp will remain on for as long as the TEST Button is held down.

● **START2 LAMP:** Select START2 LAMP and press the TEST Button to turn the option ON. The player 2 START Button will light up. The lamp will remain on for as long as the TEST Button is held down.

Move the cursor to EXIT and press the TEST Button to return to the Game Test Mode screen.



- Display of GUN MOTOR1 and GUN MOTOR2 options can be turned on or off using the DIP-SW. For cabinets with vibration motors attached to the Control Units (Guns), turn on display of the GUN MOTOR1 and GUN MOTOR2 under DIP-SW settings to alter these settings.

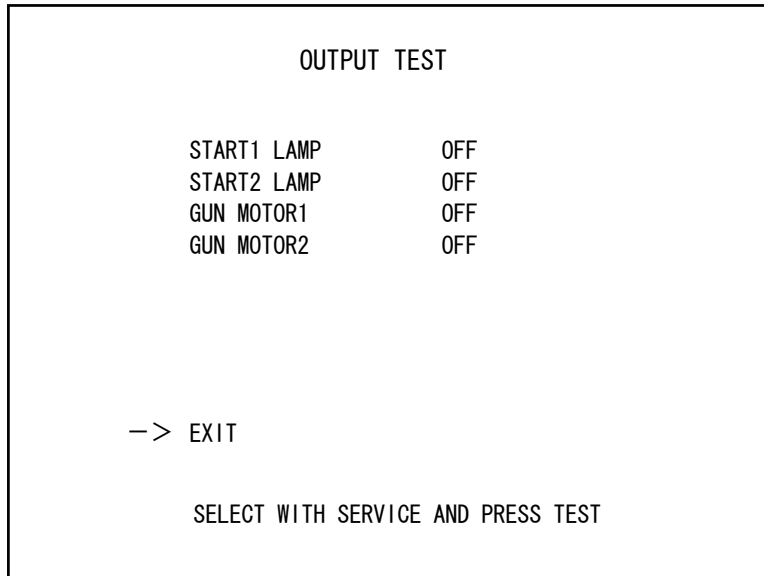

Perform the tests as follows.

- **START1 LAMP:** Select START1 LAMP and press the TEST Button to turn the option ON. The player 1 START Button will light up. The lamp will remain on for as long as the TEST Button is held down.
- **START2 LAMP:** Select START2LAMP and press the TEST Button to turn the option ON. The player 2 START Button will light up. The lamp will remain on for as long as the TEST Button is held down.
- **GUN MOTOR1:** Select GUN MOTOR1 and press the TEST Button to turn the option ON. The player 1 gun will begin to vibrate. The vibration will continue for as long as the TEST Button is held down.
- **GUN MOTOR2:** Select GUN MOTOR2 and press the TEST Button to turn the option ON. The player 2 gun will begin to vibrate. The vibration will continue for as long as the TEST Button is held down.

Move the cursor to EXIT and press the TEST Button to return to the Game Test Mode screen.

c. GAME ASSIGNMENTS

Select GAME ASSIGNMENTS to display the current game settings and make changes.

Changes to settings are not enabled until Game Assignments is exited. After changing settings, be sure to exit the Test Mode.

Use the SERVICE Button to move the cursor to the desired test item. Press the TEST Button to enter the selected item's test.

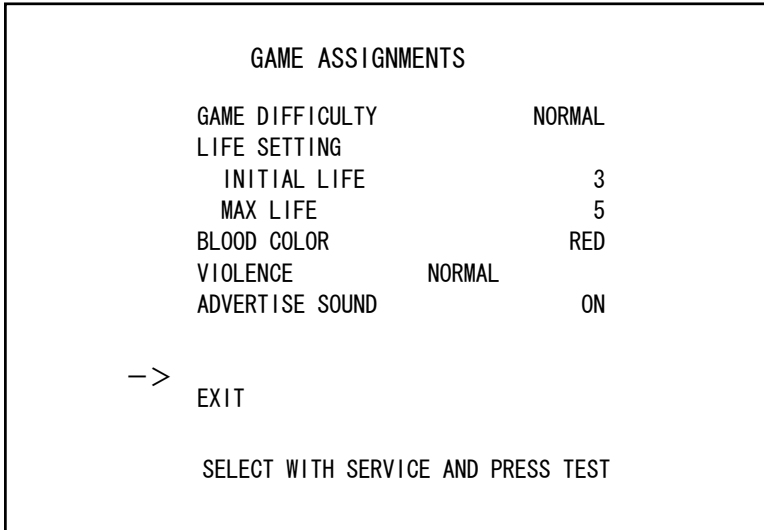

Perform the following settings for each item.

- GAME DIFFICULTY: Set the level of difficulty to one of five levels; VERY EASY -> MEDIUM EASY ->NORMAL -> MEDIUM HARD -> VERY HARD.
- LIFE SETTING INITIAL LIFE The number of lives the player will start the game with. Can be set between 1 and 9. However, cannot be set higher than the MAX LIFE setting.
- LIFE SETTING MAX LIFE: The maximum number of lives a player may have. Can be set between 1 and 9.
- BLOOD COLOR: You can set the color of blood to one of two settings; RED or BROWN.
- VIOLENCE: You can set the level of damage for the enemies to one of two settings; NORMAL or MILD. When set to MILD, the violence of enemy deaths will be toned down.
- ADVERTISE SOUND: You can set the Attract Mode (Advertise) sound to ON or OFF.

After changing the settings, select EXIT and press the TEST Button to return to the Game Test Mode screen.

d. GUN CALIBRATION SETTING

Select GUN CALIBRATION SETTING to display the following screen.
Perform the sight settings for the guns to be used in the game.

Use the SERVICE Button to move the cursor to the desired test item. Press the TEST Button to enter the selected item's test.

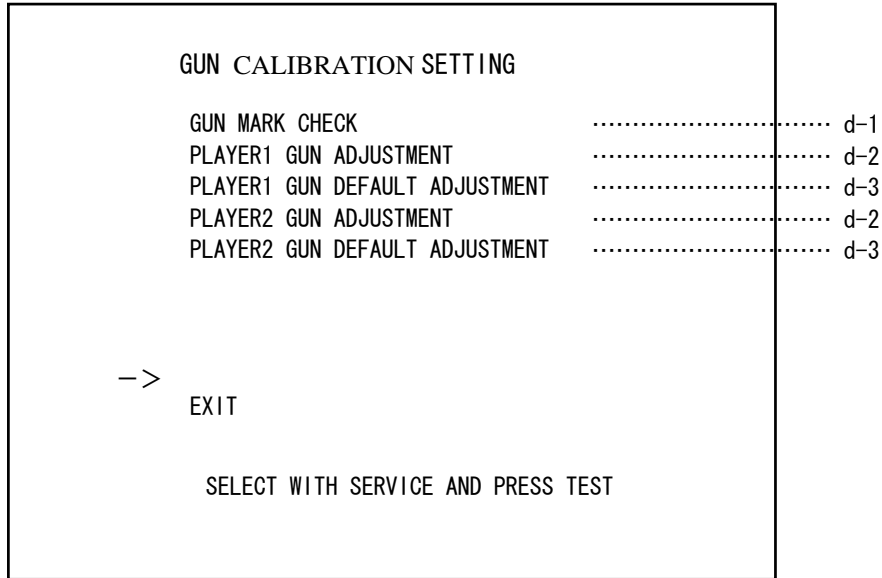

Details for each item are as follows.

- | | |
|--------------------------------------|---|
| d-1. GUN MARK CHECK: | Checks the gun sights. 1P and 2P guns are checked at the same time. |
| d-2. PLAYER1 GUN ADJUSTMENT: | Adjusts the sight for the Player 1 side. |
| d-3. PLAYER1 GUN DEFAULT ADJUSTMENT: | Adjust the default sight settings for the Player 1 side. |
| d-2. PLAYER2 GUN ADJUSTMENT: | Adjust the sight for the Player 2 side. (Operated in the same way as PLAYER1 GUN ADJUSTMENT) |
| d-3. PLAYER2 GUN DEFAULT ADJUSTMENT: | Adjust the default sight settings for the Player 2 side. (Operated in the same way as PLAYER1 GUN DEFAULT ADJUSTMENT) |

After changing the settings, select EXIT and press the TEST Button to return to the Game Test Mode screen.

d-1 GUN MARK CHECK

This checks gun sights.

Select GUN MARK CHECK on the Gun Calibration Setting screen and press the TEST Button.

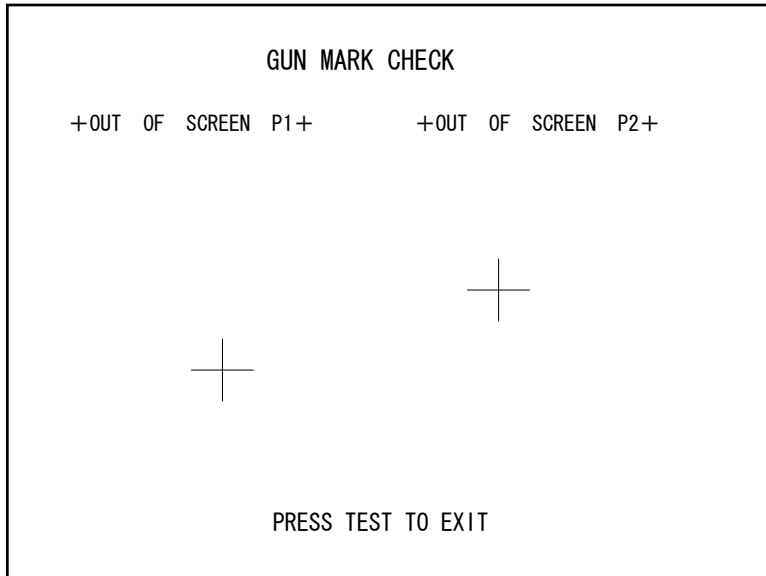

- 1P Gun Cross

This is displayed when the gun is pointed at the screen. 1P is red.

- 2P Gun Cross

This is displayed when the gun is pointed at the screen. 2P is blue.

“OUT OF SCREEN” is displayed when the gun cross is perceived to be out of screen.

Pointing the gun at the screen displays the gun cross (sight) for that gun. You can check to see if the sight lines up properly at this screen.

Press the TEST Button when everything has been checked. You will return to the Gun Calibration Setting screen.

d-2 PLAYER1 GUN ADJUSTMENT/PLAYER2 GUN ADJUSTMENT

This item adjusts the Player 1 gun sight. (This is the same for "PLAYER2 GUN ADJUSTMENT".)

Select PLAYER1 GUN ADJUSTMENT on the Gun Calibration Setting screen and press the TEST Button.

NOTE: "PLEASE SHOOT GRID WITH PLAYER1 GUN" on the screen will flash.

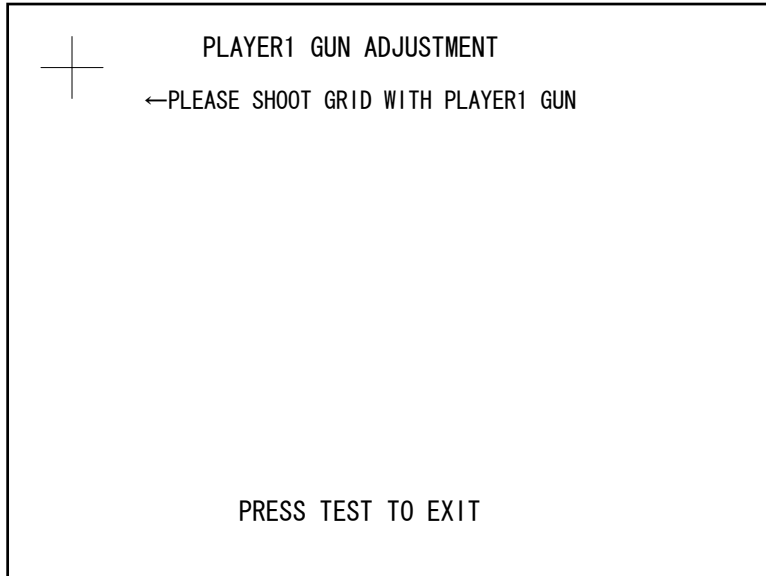

Follow the on-screen instructions to adjust the gun sight settings. Aim at the mark in the upper left corner and fire. The mark in the upper left will disappear, and the same mark will be displayed in the lower right corner.

(Press the TEST Button to return to the Gun Calibration Setting screen.)



Aim and fire at the mark to the lower right. The mark to the lower right will disappear, and the same mark will be displayed in the center.
(Press the TEST Button to return to the Gun Calibration Setting screen.)

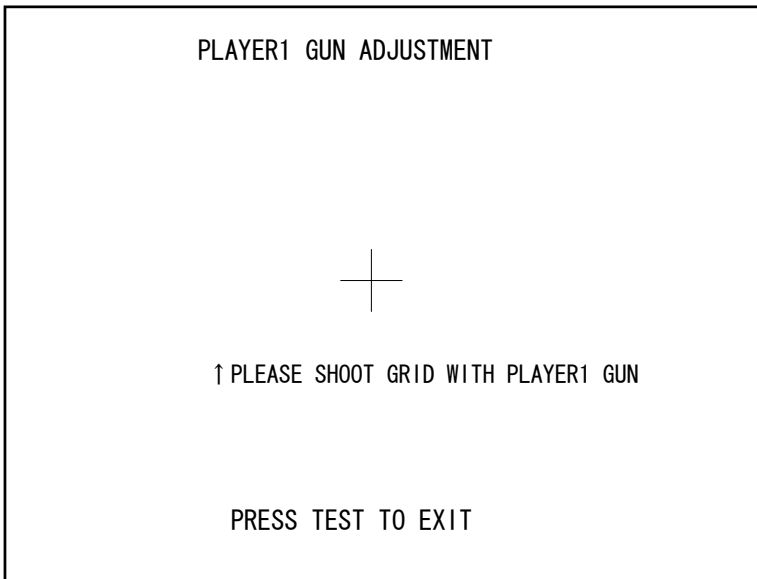

Aim and fire at the mark in the center.

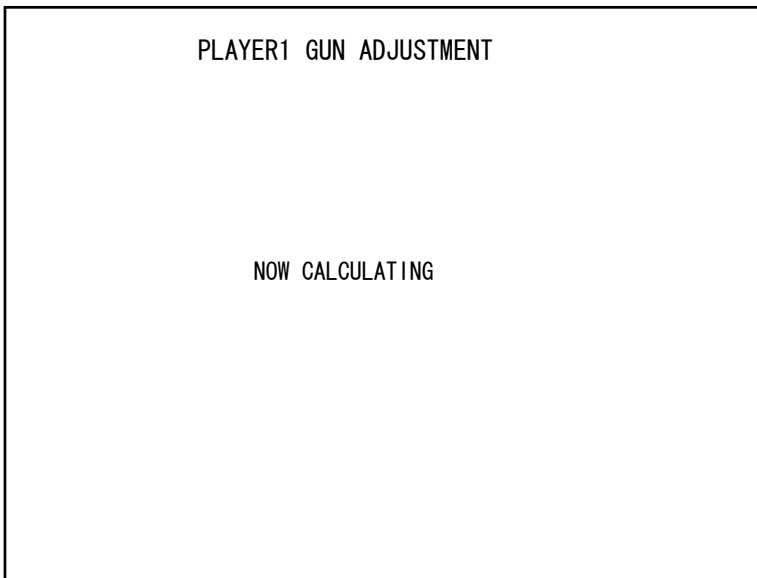

"NOW CALCULATING" will be displayed in the center. The screen will automatically switch to the following.

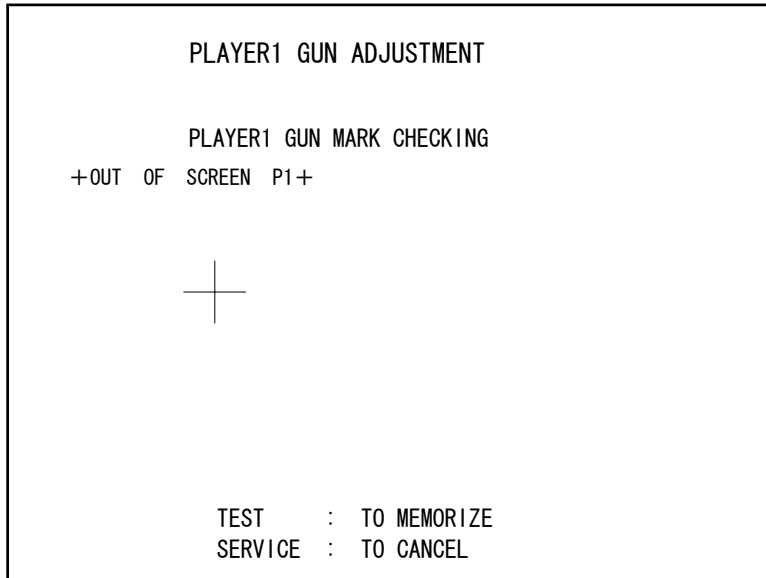

Point the Control Unit (Gun) at the screen and a gun mark will be displayed. Check to make sure that the gun can aim right up to the edges of the frame.

If the calibration is correct press the TEST Button to save it.

If re-calibration is required press the SERVICE Button. The calibration results will not be saved and you will return to the Gun Calibration Setting screen.

“OUT OF SCREEN” is displayed when the gun cross is perceived to be out of screen.

Refer to the following procedure when adjusting the sights.

- Line up the concave sight nearest you on the gun so that it is at the height of the horizontal line of the “+” mark.
- Line up the convex sight at the tip of the gun so that it also lines up with the horizontal line.
- Line up the centers of the tops of the concave and convex sights with the center of the “+” and fire.

d-3 PLAYER1 GUN DEFAULT ADJUSTMENT/PLAYER2 GUN DEFAULT ADJUSTMENT

This item adjusts the sight settings to those at the time of shipment. (This is the same for “PLAYER2 GUN DEFAULT ADJUSTMENT”.)

Select PLAYER 1 GUN DEFAULT ADJUSTMENT on the Gun Calibration Setting screen and press the TEST Button.

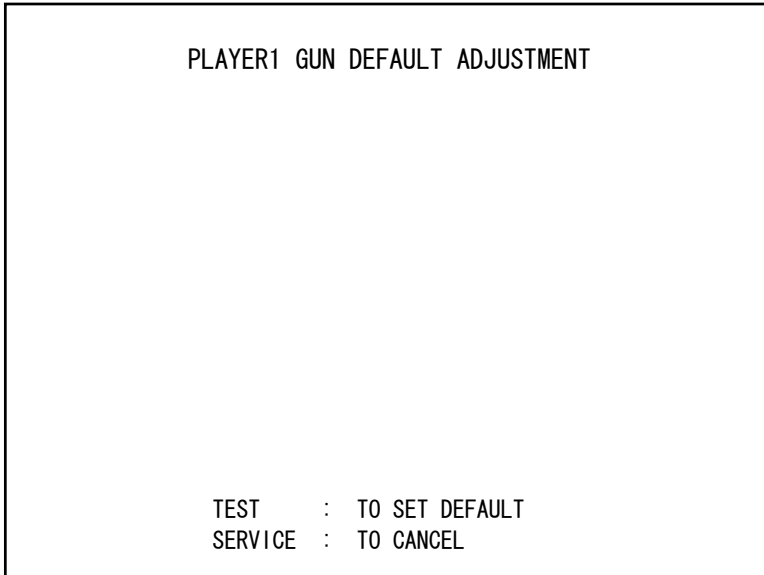

Press the TEST Button to set the Control Unit (Gun) targeting to the pre-set default values. When setting is complete the message “COMPLETED” will appear on the screen and it will then automatically proceed to the Gun Calibration Setting screen.

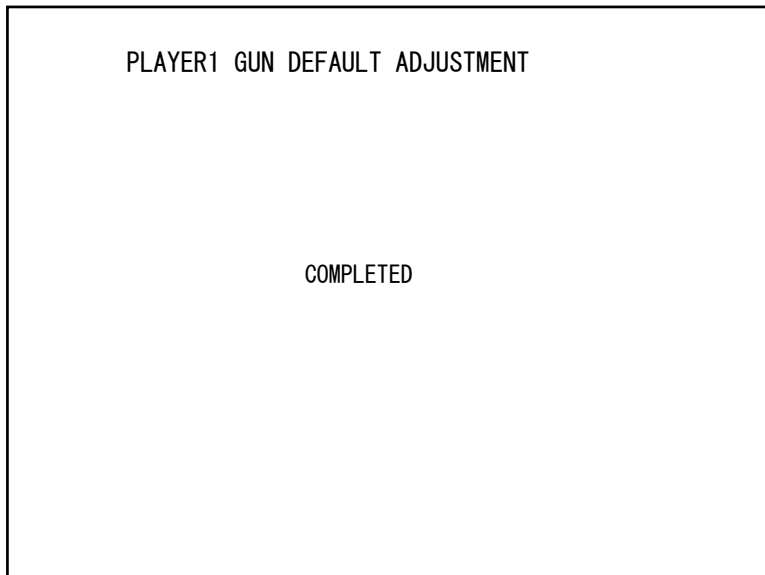

If you wish to cancel this process, press the SERVICE Button. The screen will automatically proceed to the Gun Calibration Setting screen without altering the settings for the gun.

e. GUN SPEED SETTING

Adjust the volume settings for the Control Unit's (Gun's) speed sensors.

Select GUN SPEED SETTING on the Game Test Mode screen and press the TEST Button to display the following screen.

Use the SERVICE Button to move the cursor to the desired test item. Press the TEST Button to enter the selected item's test.

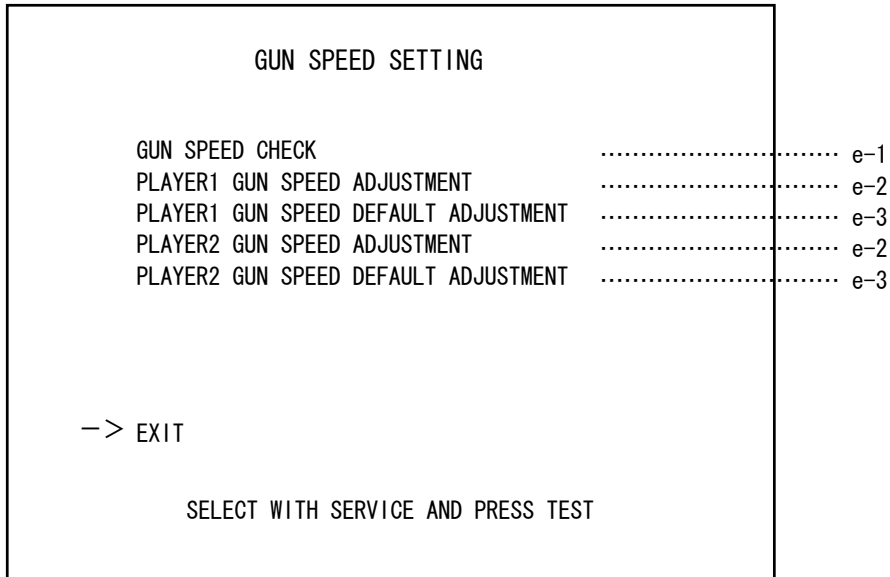

Details for each item are as follows.

e-1 GUN SPEED CHECK:

Checks the registered speed when the guns are shaken. Player 1 and Player 2 Guns are both checked together.

e-2 PLAYER1 GUN SPEED ADJUSTMENT:

Adjusts the registered speed for when the Player 1 gun is shaken.

e-3 PLAYER1 GUN SPEED DEFAULT ADJUSTMENT:

Returns the registered speed for when the Player 1 gun is shaken to the pre-set default setting.

e-2 PLAYER2 GUN SPEED ADJUSTMENT:

Adjusts the registered speed for when the Player 2 gun is shaken. (Operated in the same way as PLAYER1 GUN SPEED ADJUSTMENT.)

e-3 PLAYER2 GUN SPEED DEFAULT ADJUSTMENT:

Returns the registered speed for when the Player 2 gun is shaken to the pre-set default setting. (Operated in the same way as PLAYER1 GUN SPEED DEFAULT ADJUSTMENT.)

After changing the settings, select EXIT and press the TEST Button to return to the Game Test Mode screen.

e-1 GUN SPEED CHECK

Checks the registered speed when the Control Units (Guns) are shaken.

Select GUN SPEED CHECK on the Gun Speed Setting screen and press the TEST Button to display the following screen.

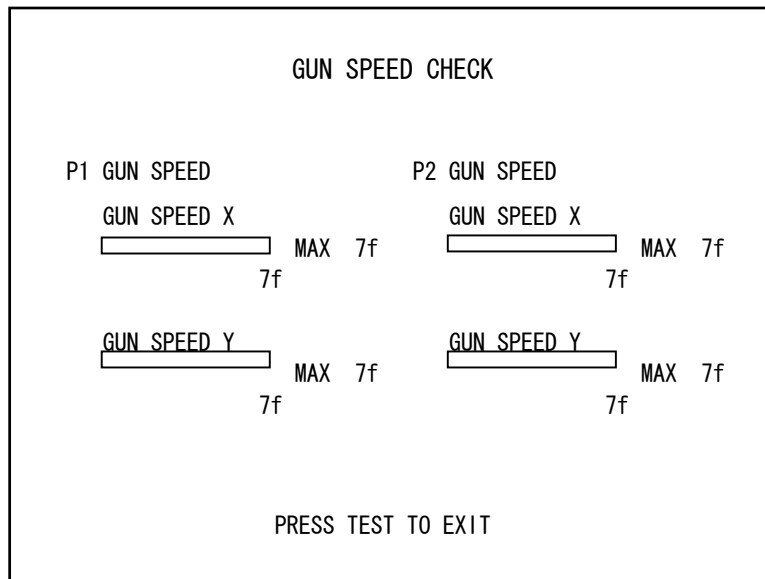

Moving the gun for each player will alter the values displayed on the X axis and Y axis speed bars. Use this screen to check that the current maximum speed setting matches the speed values by moving the guns around.

- If the numbers don't change at all:
The sensors may be broken or cables disconnected.
- If the numbers change but never reach even half of the MAX value no matter how hard the gun is moved:
There is a problem with speed settings.

Once you have finished all checks, press the TEST Button to return to the Gun Speed Setting screen.

e-2 PLAYER1 GUN SPEED ADJUSTMENT/ PLAYER2 GUN SPEED ADJUSTMENT



- Pay attention to your surroundings when moving the Control Unit (Gun) during speed adjustment so as not to hit people or objects around you. You may hurt others or yourself if due caution is not taken.



- If GUN SPEED SETTINGS are not set, or a mistake is made with the GUN SPEED SETTINGS, the gun may start to only fire single shots during the game.
- This is because the gun continually registers as having been shaken and thus continually reloads. This is not a fault with the gun itself, and can be fixed by performing GUN SPEED SETTINGS again.

Adjusts the registered speed for when the Player 1 gun is shaken. (This is the same for “PLAYER2 GUN SPEED ADJUSTMENT”.)

Select PLAYER1 GUN SPEED ADJUSTMENT on the Gun Speed Setting screen and press the TEST Button to display the following screen.

NOTE: “PLEASE SHAKE THE PLAYER1 GUN” on the screen will flash.

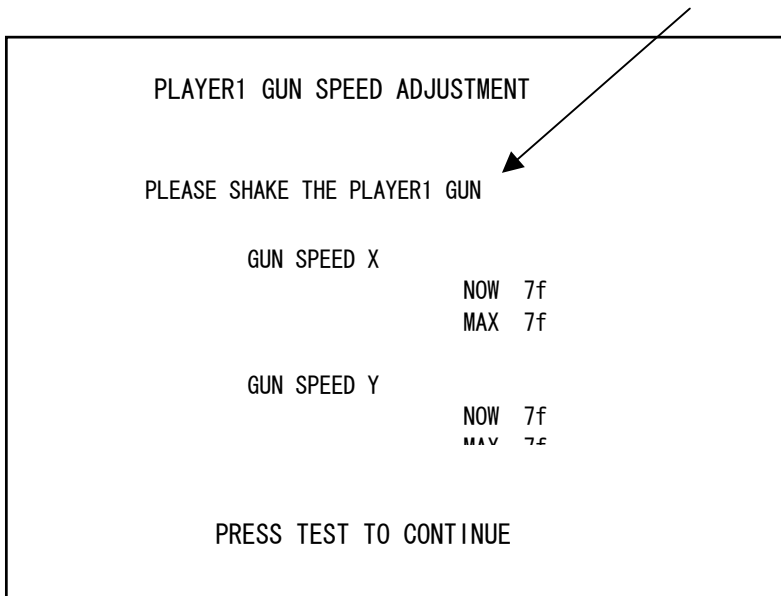

Follow the onscreen instructions to perform the gun speed settings. Shake the gun on the X axis and the Y axis and set the MAX value for each.

NOTES:

- You need only shake the gun gently on the X axis and the Y axis. If these settings are set with the gun shaken very hard it may lead to malfunctions during the game.

- Proceed to the next screen to confirm the set values. The bar here is simply for reference, and swinging the gun forcefully and filling this bar to the top is not necessary. Moving the gun lightly so that the bar is more than half full will allow the game to progress smoothly.



Press the TEST Button and the message “NOW CALCULATING” will be displayed on the screen, and it will then proceed automatically to the next screen.

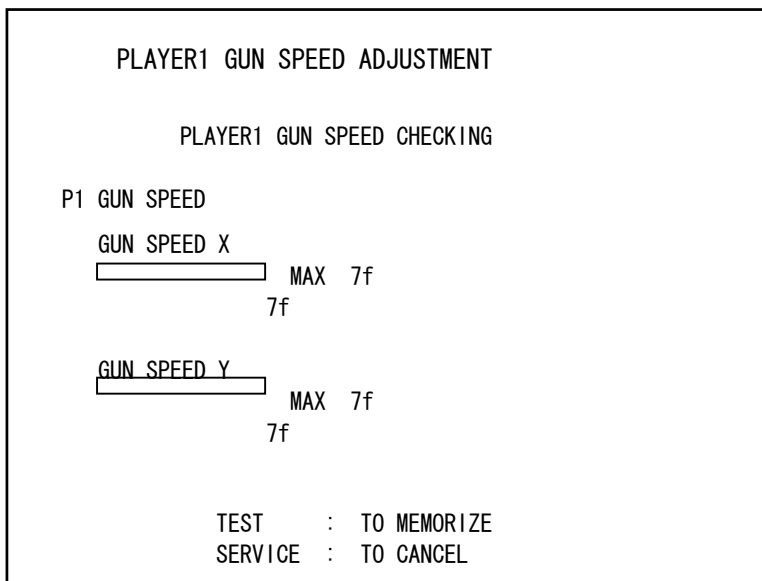

The set MAX speed values will be displayed. Move the gun again and check that these are no problems with these speed settings. If everything seems in order, press the TEST Button.

If the speed settings need to be adjusted again, press the SERVICE Button. The results of the adjustment will not be saved and the screen will return to the Gun Speed Setting screen.

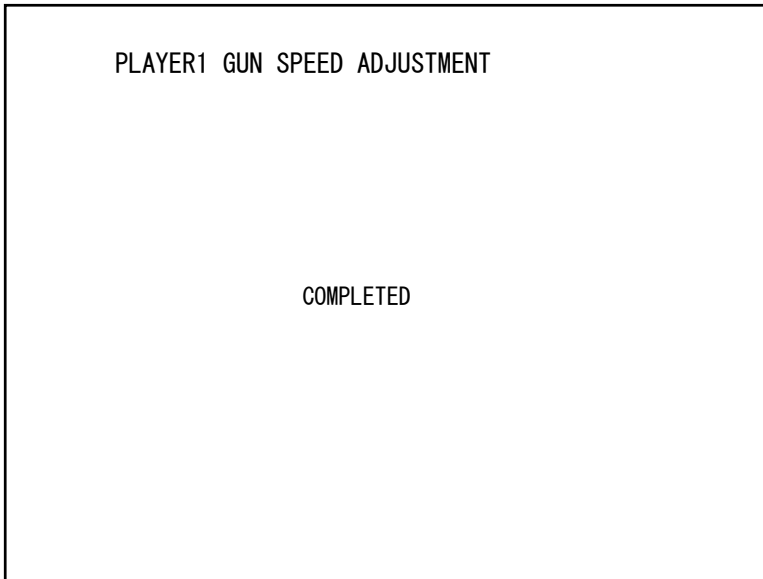

Press the TEST Button and the message "COMPLETED" will be displayed on the screen, and it will then proceed automatically to the Gun Speed Setting screen.

e. **PLAYER1 GUN SPEED DEFAULT ADJUSTMENT/ PLAYER2 GUN SPEED
DEFAULT ADJUSTMENT**

Returns the speed setting to the default factory setting.
(This is the same for “PLAYER2 GUN SPEED DEFAULT ADJUSTMENT”.)

Select **PLAYER1 GUN SPEED DEFAULT ADJUSTMENT** on the Gun Speed Setting screen and press the **TEST** Button to display the following screen.

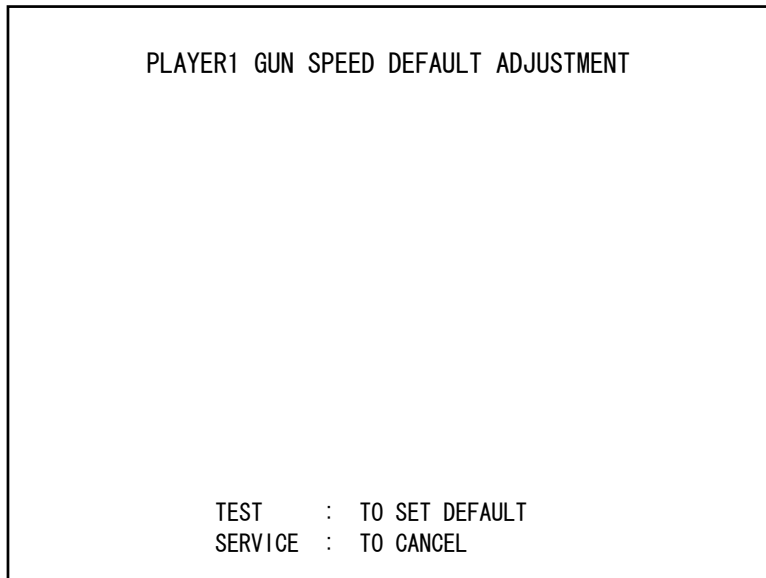

Press the **TEST** Button to set the Control Unit (Gun) speed settings to the pre-set defaults. If you wish to cancel the process, press the **SRRVICE** Button. The gun speed settings will not be changed and the screen will automatically return to the Gun Speed Setting screen.



When adjustment is complete the message “**COMPLETED**” will be displayed on the screen and it will then proceed automatically to the Gun Speed Setting screen.

f. BOOKKEEPING

Select BOOKKEEPING on the Game Test Mode screen to display the three screens of operating status data.

BOOKKEEPING	PAGE1/3
COIN 1	0
COIN 2	0
TOTAL COINS	0
COIN CREDITS	0
SERVICE CREDITS	0
TOTAL CREDITS	0

PRESS TEST TO CONTINUE

The display items for the screen (PAGE 1/3) are as follows.

- COIN 1: The number of coins inserted into Coin Slot 1.
- COIN 2: The number of coins inserted into Coin Slot 2.
- TOTAL COINS: The total number of coins inserted into the coin slots.
- COIN CREDITS: The number of credits for the coins inserted.
- SERVICE CREDITS: The number of credits input by the SERVICE Button.
- TOTAL CREDITS: The total number of all credits.

Press the TEST Button to display the next screen (PAGE 2/3).

BOOKKEEPING		PAGE2/3
NUMBER OF GAMES		0
FIRST PLAY		0
CONTINUE PLAY		0
TOTAL TIME	0D 00H 00M	
00S		
PLAY TIME	0D 00H 00M	
00S		
AVERAGE PLAY TIME	00M	
PRESS TEST TO CONTINUE		

The display items for the screen (PAGE 2/3) are as follows.

- NUMBER OF GAMES: The total number of games played by 1P and 2P.
- FIRST PLAY: The total number of games started by 1P and 2P.
- CONTINUE PLAY: The total number of continues used by 1P and 2P.
- TOTAL TIME: The amount of time the unit has been in operation.
- PLAY TIME: The amount of time the game has been played.
- AVERAGE PLAY TIME: The average play time for one game.
- LONGEST PLAY TIME: The longest play time for one game.
- SHORTEST PLAY TIME: The shortest play time for one game.

Press the TEST Button to display the next screen (PAGE 3/3).

BOOKKEEPING		PAGE3/3	
GAME HISTOGRAM			
0M 00S	□	0M 29S	0
0M 30S	□	0M 59S	0
1M 00S	□	1M 29S	0
1M 30S	□	1M 59S	0
2M 00S	□	2M 29S	0
2M 30S	□	2M 59S	0
3M 00S	□	3M 29S	0
3M 30S	□	3M 59S	0
4M 00S	□	4M 29S	0
4M 30S	□	4M 59S	0
5M 00S	□	5M 29S	0
5M 30S	□	5M 59S	0
PRESS TEST TO EXIT			

This displays play times on a scale from 0M00S to 9M59S with 30-second intervals. All play times over ten minutes are included in the item OVER 10M00S.

Press the TEST Button after viewing. You will return to the Game Test Mode screen.

g. BACKUP DATA DLEAR

Select BACKUP DATA CLEAR to clear the contents of BOOKKEEPING in the Game Test Mode and the game score.

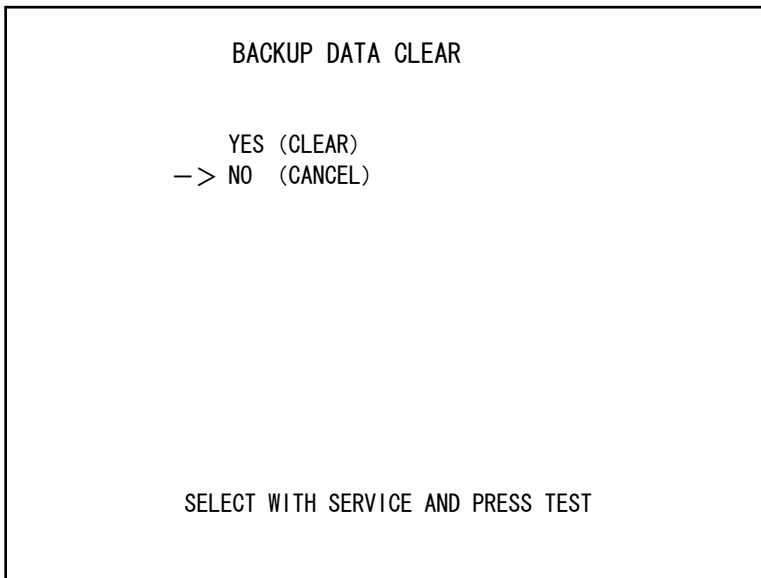

To clear data, use the SERVICE Button to move the cursor to YES (CLEAR) and then press the TEST Button.

When the data has been cleared, the message "COMPLETED" will be displayed and the screen will return to the Game Test Mode screen automatically.

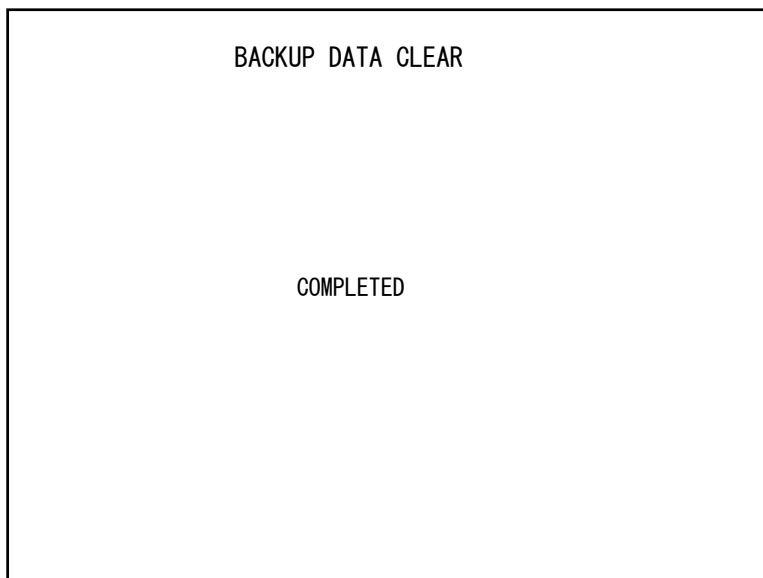

Move the cursor to NO (CANCEL) and press the TEST Button to return to the Game Test Mode screen without clearing the data.

10.1.4.ERROR CODES

Error 01

DISPLAY	Game Program Not Found.
CAUSE	The keychip is not connected.
COUNTERMEASURE	Check that the keychip is connected correctly. Check that the keychip is not inserted the wrong way or that the keychip from a different system is not inserted.

Error 02

DISPLAY	Game Program Not Available.
CAUSE	The keychip is not supported.
COUNTERMEASURE	Send the LINDBERGH board in for repair with the keychip still in place.

Error 05

DISPLAY	Wrong Region.
CAUSE	The game is for a foreign region.
COUNTERMEASURE	Use a domestic game.

Error 06

DISPLAY	I/O Device Not Found.
CAUSE	The LINDBERGH board's I/O board cannot be found.
COUNTERMEASURE	Send the LINDBERGH board in for repair with the keychip still in place.

Error 07

DISPLAY	Graphic Card Not Found.
CAUSE	The LINDBERGH board's graphics card cannot be found.
COUNTERMEASURE	Send the LINDBERGH board in for repair with the keychip still in place.

Error 08

DISPLAY	Sound Card Not Found.
CAUSE	The LINDBERGH board's sound card cannot be found.
COUNTERMEASURE	Send the LINDBERGH board in for repair with the keychip still in place.

Error 09

DISPLAY	System Memory Not Enough.
CAUSE	The LINDBERGH board does not have enough memory.
COUNTERMEASURE	Send the LINDBERGH board in for repair with the keychip still in place.

Error 10

DISPLAY	Unexpected Game Program Failure.
CAUSE	The game program crashed due to an unexpected error.
COUNTERMEASURE	Turn the power off and then restart.

Error 11

DISPLAY	JVS I/O board is not connected to main board.
CAUSE	(1) The I/O board is not connected. (2) Unreliable connection between the main board and the I/O board.
COUNTERMEASURE	(1) Connect the I/O board to the main board. Verify that the power cable is connected to I/O board. (2) Reconnect or replace the JVS cable that connects the I/O board to the main board.

Error 12

DISPLAY	JVS I/O board does not fulfill the game spec.
CAUSE	The correct I/O board is not connected.
COUNTERMEASURE	Use an I/O board that provides the proper input/output for the game.

Error 14

DISPLAY	Network firmware version does not fulfill the game spec. Required version XX.XX.
CAUSE	The firmware version installed on either the network board or the DIMM Media board is older than the required version.
COUNTERMEASURE	Use a network board or DIMM Media board with firmware that meets or exceeds the required version.

Error 15

DISPLAY	Game Program Not Found.
CAUSE	The keychip is not connected.
COUNTERMEASURE	Check that the keychip is connected correctly. Check that the keychip is not inserted the wrong way or that the keychip from a different system is not inserted.

Error 21

DISPLAY	Game Program Not Found on Game Disk.
CAUSE	There is no program image on the game disk.
COUNTERMEASURE	Check that a game disk corresponding to the keychip is inserted into the drive.

Error 22

DISPLAY	Game Program Not Found on Device.
CAUSE	There is no game image on the game installer device.
COUNTERMEASURE	Perform a reinstall from the game disk.

Error 24

DISPLAY	DVD Drive Not Found.
CAUSE	The DVD drive cannot be found.
COUNTERMEASURE	Connect the DVD drive.

Error 25

DISPLAY	Game Disk Not Found.
CAUSE	The game disk cannot be found.
COUNTERMEASURE	Insert the game disk.

Error 26

DISPLAY	Storage Device Not Found.
CAUSE	The program installer device cannot be found.
COUNTERMEASURE	Send the LINDBERGH board in for repair with the keychip still in place.

Error 27

DISPLAY	Storage Device is Not Acceptable.
CAUSE	The program installer device does not have enough space.
COUNTERMEASURE	Send the LINDBERGH board in for repair with the keychip still in place.

Error 28

DISPLAY	This Game Disk is Not Acceptable.
CAUSE	The game disk cannot be read correctly.
COUNTERMEASURE	Exchange the game disk for a proper game disk. Check that the game disk is not scratched, damaged or dirty.

Error 29

DISPLAY	Cannot Control DVD Drive.
CAUSE	The DVD drive cannot be controlled.
COUNTERMEASURE	The DVD drive may be damaged.

Error 31

DISPLAY	Storage Device Not Enough.
CAUSE	The program installer device does not have enough space.
COUNTERMEASURE	Send the LINDBERGH board in for repair with the keychip still in place.

Error 32

DISPLAY	Installing Game Program Failed.
CAUSE	Transfer of the program failed.
COUNTERMEASURE	Check that the DVD drive is connected correctly. Check that the game disk is not scratched, damaged or dirty.

Error 33

DISPLAY	Storage Device is Not Acceptable.
CAUSE	The program installer device cannot be found.
COUNTERMEASURE	Send the LINDBERGH board in for repair with the keychip still in place.

Error 34

DISPLAY	Storage Device Not Found.
CAUSE	The program installer device cannot be found.
COUNTERMEASURE	Send the LINDBERGH board in for repair with the keychip still in place.

Error 35

DISPLAY	Storage Device is Not Acceptable.
CAUSE	The program installer device does not have enough space.
COUNTERMEASURE	Send the LINDBERGH board in for repair with the keychip still in place.

Error 36

DISPLAY	Storage Device May be Broken.
CAUSE	The program installer device is broken.
COUNTERMEASURE	Send the LINDBERGH board in for repair with the keychip still in place.

Error 37

DISPLAY	Verifying Game Program Failed.
CAUSE	The program image is unverified due to the program image not existing on the game disk or server.
COUNTERMEASURE	Check that the correct game disk is inserted.

Error 41

DISPLAY	Server Not Respond.
CAUSE	The server is not responding.
COUNTERMEASURE	Check the network settings. Set IP Address and other settings. Check that the network cable has not been pulled out.

Error 42

DISPLAY	Server Mount Failed
CAUSE	The server directory is could not be reached.
COUNTERMEASURE	Check the network settings. Set IP Address and other settings. Check that the network cable has not been pulled out.

Error 43

DISPLAY	IP Address Not Assigned.
CAUSE	An IP Address could not be obtained from the DHCP server.
COUNTERMEASURE	Check the network settings. Set IP Address and other settings. Check that the network cable has not been pulled out.

Error 44

DISPLAY	Game Program Not Found on Server.
CAUSE	No program image on the network server.
COUNTERMEASURE	Check that the game title, place on the network server, and the keychip correspond to each other.

Caution 51

DISPLAY	Wrong Resolution Setting.
CAUSE	The game does not support the current resolution settings.
COUNTERMEASURE	Change the DIP SW to the correct settings and restart.

Caution 52

DISPLAY	Wrong Horizontal/Vertical Setting.
CAUSE	The monitor horizontal/vertical settings are incorrect.
COUNTERMEASURE	Change the DIP SW to the correct settings and restart.

10.2. COIN MECH INSTALLATION AND CREDIT BOARD SET UP

10.2.1.INTRODUCTION

Game credits between the Coin Mechanism and the game board for this machine are controlled by a **VTS board**. This electronic circuit allows the price of play to be set for a range of different countries. These functions are set on Dual In Line (DIL) PCB mounted switches.

DIL-2 is used to set the currency (or coin ratio) and DIL-1 the price of play. Refer to the Tables on the following pages for the correct settings for your environment.

The *Klingon2* board pictured below is mounted on the VTS Bracket within the Coin Chute Tower.

The *Klingon2* board is connected to the coin validator and lamps via a dedicated wiring harness depending upon the coin validator used:

Wiring Harness	Validator	
LM1006	Coin Controls	(15 way connector)
LM1007	Mars	(13 way connector)
LM1008	Mechanical	See note 2
N/A	NRI	See note 1

Notes

1. If NRI mechanisms are to be used, these should be ordered with the highest denomination coin on coin path #1 and the lowest denomination on coin path #4. The VTS board should be then be set up for either the UK or EURO settings. A minimum connecting lead length of 600mm is required.
2. Mechanical coin mechanisms may be connected in parallel allowing two identical mechanisms to be fitted.

Illustration showing COIN TOWER, VTS PCB, COIN VALIDATOR and ASSOCIATED HARNESSSES



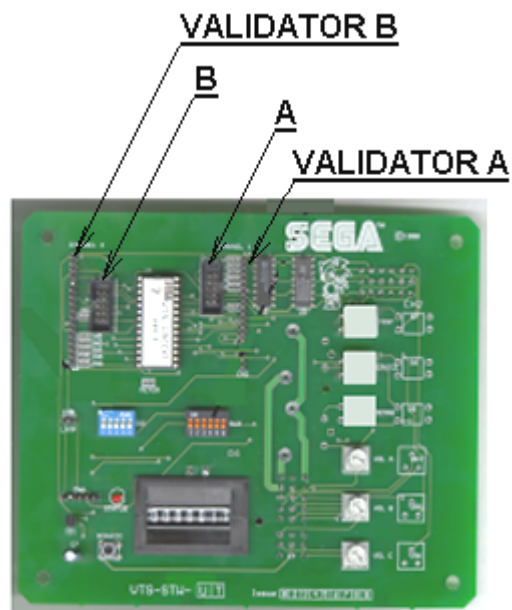

Illustration shows VTS PCB.

All COIN ASSIGNMENTS are carried out and processed by the VTS Board. This game uses a single SR3 Coin Validator (if supplied). This Validator will connect into port A as indicated by the illustration above.

All Credit settings are configured via the DIP switches also located on the VTS Board (please refer to later on in this manual for the appropriate switch settings).

IMPORTANT – The CREDIT SETTINGS as displayed in the COIN ASSIGNMENTS of the SYSTEM TEST MODE in the LINDBERGH TEST MENU should always be set to 1 COIN = 1 CREDIT to maintain a correct output from the VTS.

10.2.2.VTS CREDIT BOARD OPTION SETTINGS

Credit Board Mode Settings Switch 3																				
Country	Setting	Switch 3 Setting						Coin Validator Programming								C120/SR3 Only				
		SW1	SW2	SW3	SW4	SW5	SW6	COIN1	COIN2	COIN3	COIN4	COIN5	COIN6	COIN7	COIN8	COIN9	COIN10	COIN11	COIN12	
UK	Coin Controls C220 Parallel	OFF	OFF	OFF	OFF			£1	50p new	20p	10p	-	50p old	-	-					
UK	Coin Controls C220 Binary	ON	OFF	OFF	OFF			£1	50p new	20p	10p	-	50p old	-	£2					
UK	Coin Controls C220 Binary	OFF	ON	OFF	OFF			£1	50p new	20p	10p	-	£2	-	50p old					
UK	Coin Controls SR3 Parallel	ON	ON	OFF	OFF			£1	50p new	20p	10p	-	£2	-	50p old	-	-	-	-	
UK Euro	Coin Controls SR3 Parallel	OFF	OFF	ON	OFF			£2 €2	£1 €1	50p new 50¢	20p 20¢	10p 10¢	-	-	-	50p old	-	-	-	
UK	Mars ME/MS 111 Parallel	ON	OFF	ON	OFF			£1	£2	20p	10p	50p new	50p old							
UK	NRI Parallel	OFF	ON	ON	OFF			10p	20p	50p	£1	£2	-							
Belgium	Parallel	ON	ON	ON	OFF			-	50BFr	20BFr	5BFr									
Holland	Parallel	OFF	OFF	OFF	ON			-	5NLG	2.5NLG	1NLG									
Austria	SR3 Parallel	ON	OFF	OFF	ON			20Sch	10Sch	5Sch	1Sch									
Spain	Coin Controls C220 Binary	OFF	ON	OFF	ON			500Pta	200Pta	100Pta	50Pta	25Pta	200Pt old	50Pta old	25Pta old					
Spain	SR3/NRI Parallel	ON	ON	OFF	ON			500Pta	200Pta	100Pta	50Pta	25Pta	-	-	200Pta	-	50Pta old	25Pta old	-	
Spain	Coin Controls C220 Parallel	OFF	OFF	ON	ON			100Pta	50Pta new	-	25Pta new	-	50Pta old	-	25Pta old					
Portugal Euro	Parallel	ON	OFF	ON	ON			200Es €1	100Es 50¢	50Es	-	-	-	-	-					
	TBA					OFF		TBA					Please Note The credit board automatically sets the validator for parallel and binary operation through an output on pin 8 of the 17 way pinstrip. For the feature to work it is necessary for the validator interconnecting cable to include at wire at this position							
						ON		TBA												
	Channels					OFF		Direct Mode												
						ON		2 channel Mode												

Note: These switch settings are under constant review and may change due to world currency updates.

- Set SW 1 according to the option settings found in the relevant Price of Play Settings Table on the following pages.
- For Germany (DM), France (Fr) & Switzerland (SFr), use the appropriate existing setting shown above (from another country) that matches the coin ratios programmed into your coin mech.
- Set SW 3 on the VTS /Excel board as shown in the table above corresponding to the country required.

10.2.3.PRICE OF PLAY SETTINGS UK

	Price	Bonus			DIL Switch 1				
					Switch 1	Switch 2	Switch 3	Switch 4	Switch 5
1	10p	No Bonus			OFF	OFF	OFF	OFF	OFF
2	10p	6 = 50p			ON	OFF	OFF	OFF	OFF
3	20p	No Bonus			OFF	ON	OFF	OFF	OFF
4	20p	3 = 50p	6 = £1	12 =£2	ON	ON	OFF	OFF	OFF
5	30p	No Bonus			OFF	OFF	ON	OFF	OFF
6	30p	1.66 = 50p	4 = £1	8 = £2	ON	OFF	ON	OFF	OFF
7	30p	2 = 50p	4 = £1		OFF	ON	ON	OFF	OFF
8	30p	AMLD *	3 = £1	6 = £2	ON	ON	ON	OFF	OFF
9	40p	No Bonus			OFF	OFF	OFF	ON	OFF
10	40p	1.25 = 50p	3 = £1	6 = £2	ON	OFF	OFF	ON	OFF
11	50p	No Bonus			OFF	ON	OFF	ON	OFF
12	50p		3 = £1	6 = £2	ON	ON	OFF	ON	OFF
13	50p		2 = £1	5 = £2	OFF	OFF	ON	ON	OFF
14	60p	No Bonus			ON	OFF	ON	ON	OFF
15	60p		2 = £1	4 = £2	OFF	ON	ON	ON	OFF
16	80p	No Bonus			ON	ON	ON	ON	OFF
17	80p	1.25 = £1	2 = £1.50	2.5 = £2	OFF	OFF	OFF	OFF	ON
18	£1	No Bonus			ON	OFF	OFF	OFF	ON
19	£1		3 = £2		OFF	ON	OFF	OFF	ON
20	£1		2 = £2	5 = £4	ON	ON	OFF	OFF	ON
21	£1.50	No Bonus			OFF	OFF	ON	OFF	ON
22	£1.50		2 = £2		ON	OFF	ON	OFF	ON
23	£2	No Bonus			OFF	ON	ON	OFF	ON
24	£2			3 = £5	ON	ON	ON	OFF	ON
25	£3	No Bonus			OFF	OFF	OFF	ON	ON
26	£3			2 = £5	ON	OFF	OFF	ON	ON
27	£5	No Bonus			OFF	ON	OFF	ON	ON
28	£5			3 = £10	ON	ON	OFF	ON	ON
29	£7.50	No Bonus			OFF	OFF	ON	ON	ON
30	£7.50			2 = £10	ON	OFF	ON	ON	ON
31	£10	No Bonus			OFF	ON	ON	ON	ON
32	Free Play				ON	ON	ON	ON	ON

10.2.4.PRICE OF PLAY SETTINGS EURO

	Price	Bonus			DIL Switch 1				
					Switch 1	Switch 2	Switch 3	Switch 4	Switch 5
1	10¢	No Bonus			OFF	OFF	OFF	OFF	OFF
2	10¢	6 = 50¢			ON	OFF	OFF	OFF	OFF
3	20¢	No Bonus			OFF	ON	OFF	OFF	OFF
4	20¢	3 = 50¢	6 = €1	12 = €2	ON	ON	OFF	OFF	OFF
5	30¢	No Bonus			OFF	OFF	ON	OFF	OFF
6	30¢	1.66 = 50¢	4 = €1	8 = €2	ON	OFF	ON	OFF	OFF
7	30¢	2 = 50¢	4 = €1		OFF	ON	ON	OFF	OFF
8	30¢	AMLD *	3 = €1	6 = €2	ON	ON	ON	OFF	OFF
9	40¢	No Bonus			OFF	OFF	OFF	ON	OFF
10	40¢	1.25 = 50¢	3 = €1	6 = €2	ON	OFF	OFF	ON	OFF
11	50¢	No Bonus			OFF	ON	OFF	ON	OFF
12	50¢		3 = €1	6 = €2	ON	ON	OFF	ON	OFF
13	50¢		2 = €1	5 = €2	OFF	OFF	ON	ON	OFF
14	60¢	No Bonus			ON	OFF	ON	ON	OFF
15	60¢		2 = €1	4 = €2	OFF	ON	ON	ON	OFF
16	80¢	No Bonus			ON	ON	ON	ON	OFF
17	80¢	1.25 = £1	2 = €1.50	2.5 = €2	OFF	OFF	OFF	OFF	ON
18	€1	No Bonus			ON	OFF	OFF	OFF	ON
19	€1		3 = €2		OFF	ON	OFF	OFF	ON
20	€1		2 = €2	5 = €4	ON	ON	OFF	OFF	ON
21	€1.50	No Bonus			OFF	OFF	ON	OFF	ON
22	€1.50		2 = €2		ON	OFF	ON	OFF	ON
23	€2	No Bonus			OFF	ON	ON	OFF	ON
24	€2			3 = €5	ON	ON	ON	OFF	ON
25	€3	No Bonus			OFF	OFF	OFF	ON	ON
26	€3			2 = €5	ON	OFF	OFF	ON	ON
27	€5	No Bonus			OFF	ON	OFF	ON	ON
28	€5			3 = €10	ON	ON	OFF	ON	ON
29	€7.50	No Bonus			OFF	OFF	ON	ON	ON
30	€7.50			2 = €10	ON	OFF	ON	ON	ON
31	€10	No Bonus			OFF	ON	ON	ON	ON
32	Free Play				ON	ON	ON	ON	ON

11. CONTROLLER UNIT (GUN)



- In order to prevent any electric shocks or short circuits, be sure to turn the power off before performing any work that involves touching the interior parts of the product.
- Be careful not to damage the wires. Damaged wires may cause electric shocks or short circuits, or present a risk of fire.
- Be very careful when soldering. Handling a soldering iron carelessly may result in a fire or burns.



- When securing the plastic-made parts, do not excessively fasten screws and nuts. Failure to do this may damage the parts, and fragments resulting from damage may cause injury.
- When reassembling the Control Unit (Gun), be sure to check the connecting portion and the trigger, etc. If the reassembly work is insufficient and/or incorrect, fingers may be caught and result in injury.
- Make sure that there is no gap when attaching cover L and R. A gap or crack may trap hands or fingers and lead to injury.



- Do not cut the tie belt securing the wires in the Control Unit (Gun). Cutting the tie belt may cause malfunctioning of the wire connection. If you cut the tie belt when replacing the wire etc., be sure to secure the wires using a new tie belt as before.
- After taking the Control Unit (Gun) apart, always use "Tightening Adhesive" (part number: 090-0012). Apply an appropriate amount to the screw and then tighten it up. If you do not use "Tightening Adhesive" there is a risk of looseness or the Control Unit (Gun) coming apart.
- Only use the tightening adhesive specified by this manual. Using any other "Tightening Adhesive" may cause a chemical reaction that renders the screws useless or damage the surface of the Control Unit (Gun).
- Follow these directions carefully to avoid damaging or losing small parts.
- After exchanging any parts, always enter Test Mode and adjust/check the Control Unit (Gun).

If there appears to be a problem with the gun and adjustment in Test Mode makes no difference, part of the gun is most likely broken.

Use the following instructions to take the gun apart and replace the broken part. The exterior casing, comprised of cover L and cover R, must be opened up in order to change interior parts.

As some internal parts are connected to cover R, work with cover R face down on the working surface.

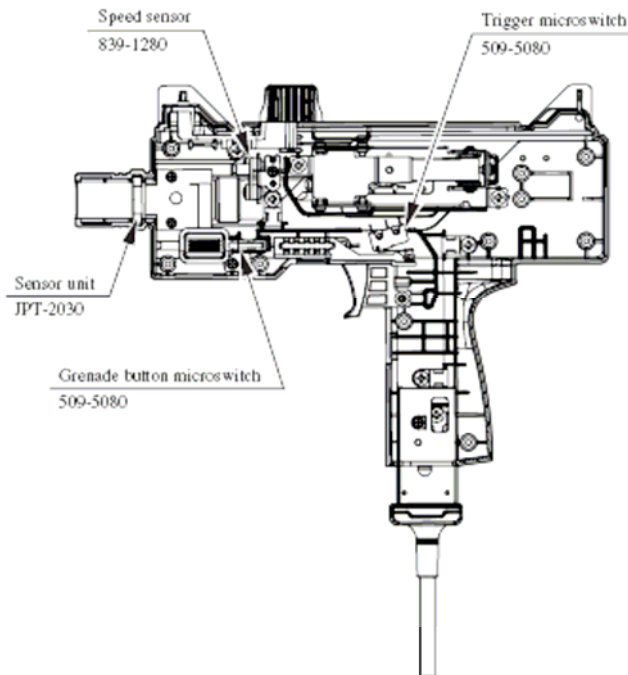

FIG. 10 a (Unit Interior)

Replacing the Microswitch

The Control Unit (Gun) houses two microswitches, the trigger microswitch and the grenade button microswitch.

- ① Turn off power to the cabinet.
- ② Removing all 9 screws will allow cover L and cover R to be taken apart. Remove all 9 screws.

SCREW (9), black
M3×12, w/small flat & spring washers



PHOTO 10 a

- ③ Place cover R face down on the work surface and slowly lift cover L directly upward.



PHOTO 10 b

- ④ Lift the trigger microswitch up from where it is attached to cover R.

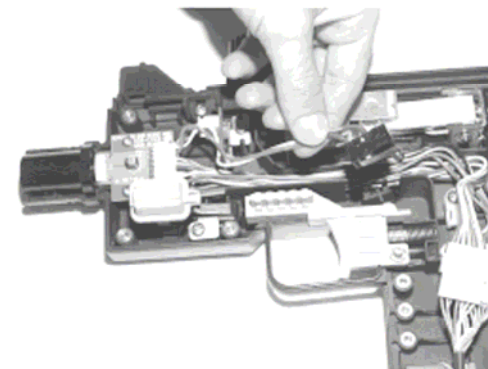

PHOTO 10 c

remove the microswitch.

- ⑥ The grenade button microswitch is located at the base of the grenade button. Lift the grenade button free of cover R.

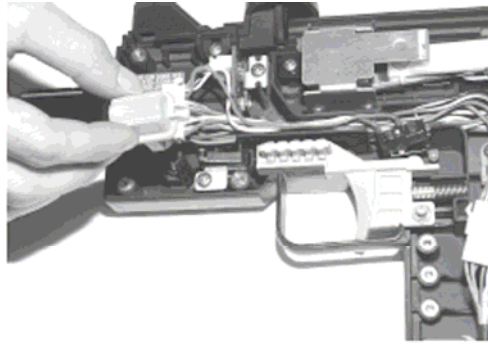

PHOTO 10 d

- ⑦ Remove the screw and remove microswitch cover R.

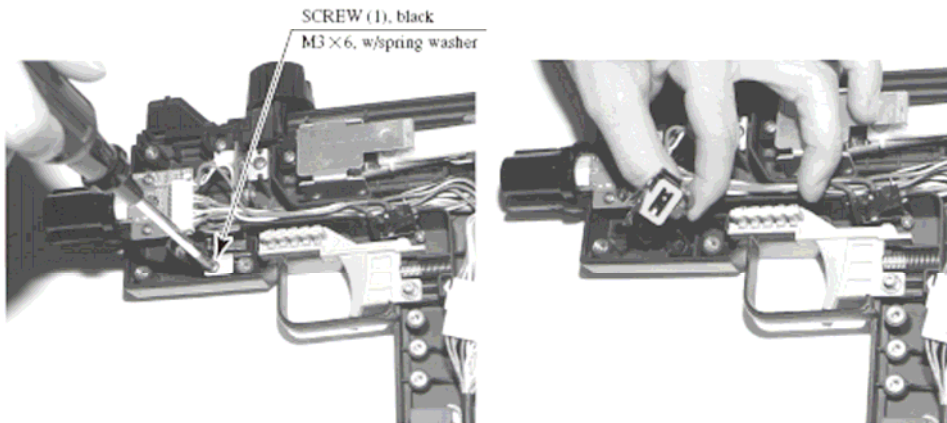

PHOTO 10 e

- ⑧ Undo the brackets and remove the solder to allow you to remove the microswitch.

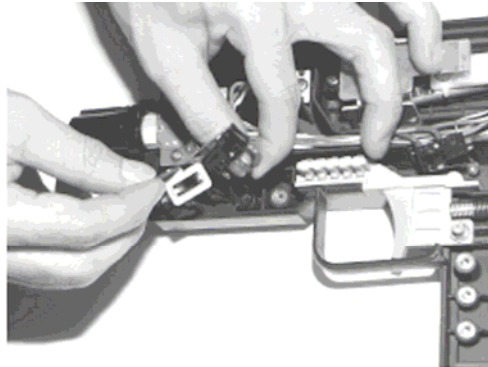

PHOTO 10 f

- ⑨ Solder the new microswitch in place on the gun.
Then operate all buttons on the gun and confirm that the microswitch turns ON/OFF before putting covers L and R back together.
Do not tighten the screws too tightly when reattaching the covers.
- ⑩ Perform an input test as described in the chapter on "Test Mode."

Replacing the Sensor Unit

- ① Follow steps ① - ③ above of the microswitch replacement procedure. You will now have removed cover L.
- ② Undo the connector and remove the sensor unit.

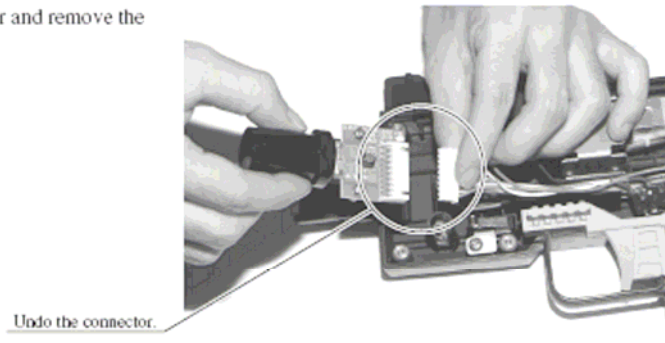

PHOTO 10 g

- ③ Attach the new sensor unit and fit it back in place inside the Control Unit (Gun).
Then operate all buttons on the gun and confirm that the microswitch turns ON/OFF before putting covers L and R back together.
Do not tighten the screws too tightly when reattaching the covers.
- ④ Perform a targeting test as described in the chapter on "Test Mode."

Replacing the Speed Sensor

- ① Follow steps ① - ③ above of the microswitch replacement procedure. You will now have removed cover L.
- ② Remove 1 screw.

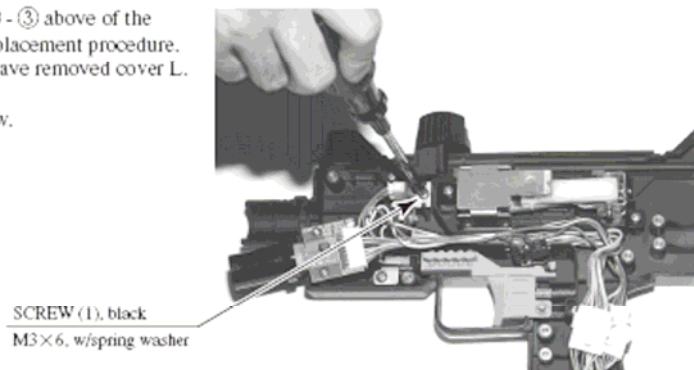

PHOTO 10 h

- ③ Remove cover R from the speed sensor and undo the connector.

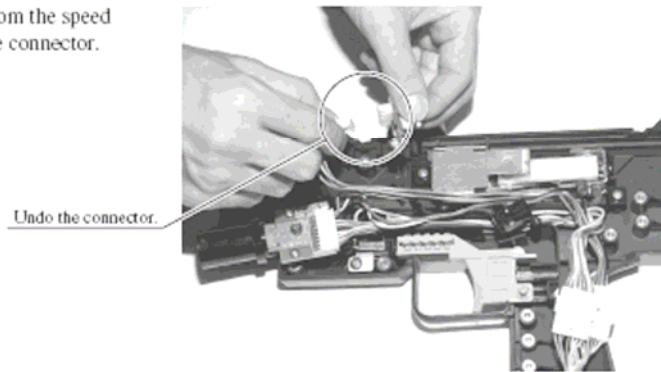

PHOTO 10 i

- ④ Undo the 2 screws and separate the sensor (board) and brackets. The brackets, screws and plastic washers will be used with the new sensor so do not lose them.

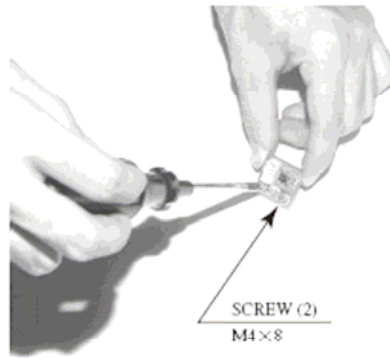

PHOTO 10 j

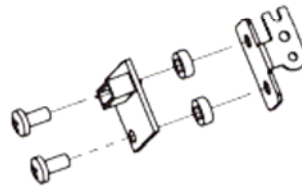

FIG. 10 b

- ⑤ Replace the sensor and paying careful attention to all parts involved place it inside the gun. Pass the screws through the sensor, plastic washers and then the bracket in order.
- ⑥ Perform a speed test as described in the chapter on "Test Mode."

12. REPLACEMENT OF FLOURESCENT LAMPS



- When performing the work, be sure to sure power off. Working with power on can cause an electric shock or short circuit accident.
- Hot fluorescent lamp can cause burns. Be very careful when replacing them.

BILLBOARD LAMP REPLACEMENT

- 1) Take off screws and remove the Upper and Lower Billboard Sash.
- 2) Pull out the Billboard from the cabinet to replace the Fluorescent.

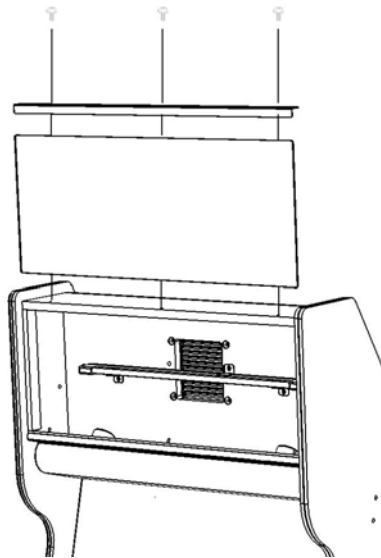

- 3) Reassemble in reverse process. (The Part number for the lamp = 390-7001-20W-UK)

DOWNLIGHT LAMP REPLACEMENT

- 1) Remove the 6 screws that secure the LIGHT BOX COVER.
- 2) Remove the LIGHT BOX COVER to reveal the ASSY LIGHT.

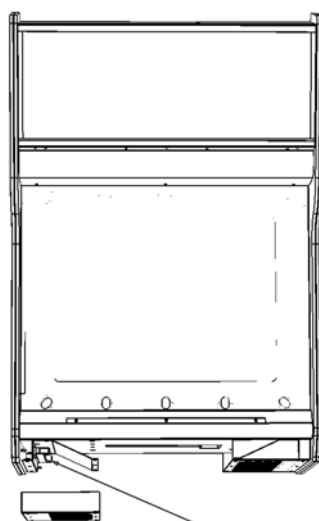

Flo Lamp - Pt No. 390-7001-08-UK

- 3) Reassemble in reverse process.

START LAMP REPLACEMENT

- Following the procedure in the “Gun Cabinet Lamp replacement” to remove the ASSY CONTROL PANEL.
- Locate the ASSY SWITCH with the defective lamp and twist to remove.
- Pull the bulb from the lamp housing and replace by push to fit.
- This product uses a LED lamp. The BULB represented in the image to the right is an alternative.
- Re-assemble in reverse.

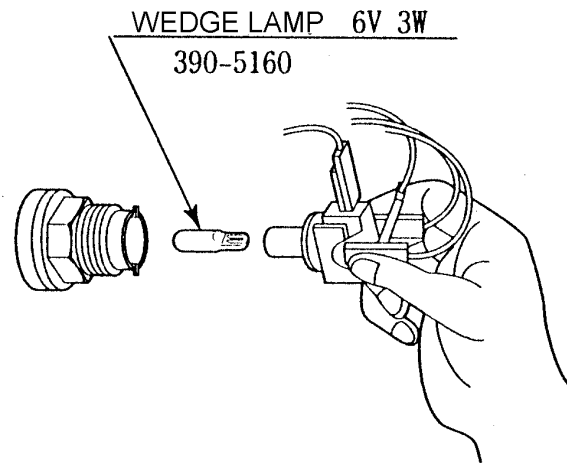

13. PERIODIC INSPECTION TABLE

The items listed below require periodic check and maintenance to retain the performance of this machine and to ensure safety business operation.



- Be sure to check ones a year to see if Power Cords are damaged, the plug is securely inserted, dust is accumulated between the Socket Outlet and the Power Plug, etc. Using the product with dust as is accumulated can cause a fire or electric shock.
- Periodically once a year, required the place of contact herein started or the Distributor, etc. Where the product with dust as is accumulated in the interior without cleaning can cause a fire or accident. Note that cleaning the interior parts can be performed on a pay-basis.

ITEMS	DESCRIPTION	PERIOD
CONTROLLER	Check SW	Monthly
	Checking the Trigger Switch	Monthly
	Greasing	Tri-monthly
COIN CHUTE DOOR	Check COIN SW	Monthly
	Coin insertion test	Monthly
	COIN SELECTOR cleaning	Tri-monthly
MONITOR	Cleaning CRT face	Weekly
	Check adjustment	Monthly
GAME BD	MEMORY TEST	Monthly
	Setting check	
INTERIOR	Cleaning	Annually
POWER PLUG	Inspection and cleaning	
Cabinet surface	Cleaning	As occasion arises

CAUTION TO BE HEEDED WHEN CLEANING THE CRT SURFACE



Static preventive coating is applied to the CRT surface. When clearing, pay attention to the following points. Peeling off of static preventive coat can cause electric shock.

- Remove smears by using a dry, soft cloth (flannels, etc.). Do not use a coarse gauze, Etc.
- For smear removing solvent, alcohol (ethanol) is recommended. When using chemical detergent, be sure to follow instructions below:
- Dilute chemical detergent with water and dip a soft cloth in and then thoroughly wring it to wipe smears off
- Do not use a chemical detergent containing an abrasive powder or bleaching agent.
- Do not use alkaline chemical detergents such as "glass cleaner," or solvent such as thinners, etc.
- Do not rub or scratch the CRT face with hard items such as brushes, scrub brush, etc.

CLEANING THE CABINET SURFACES

If the Cabinet is badly stained, use a cloth which has the chemical detergent liquid diluted with water and then squeezed dry. Do not use thinners, benzine, alcohol or chemical dust cloth as they can damage the Cabinet surface.

14. TROUBLESHOOTING



WARNING

- In order to prevent an electrical shock, be sure to turn power off before performing work by touching the interior parts of the product.
- Be careful so as not to damage wirings. Damaged wiring can cause an electrical shock or short circuit accident.

For troubleshooting, first check the connection of wiring connectors.

PROBLEMS	CAUSE	COUNTERMEASURES
When the main SW is turned ON, the machine is not activated.	The power is not ON.	Firmly insert the plug into the outlet.
	Incorrect power source/voltage.	Make sure that the power supply/voltage are correct.
	The CIRCUIT PROTECTOR functioned due to momentary over current.	Remove the cause of overload to reset the circuit protector
	The fuse is blown due to instantaneous overload.	After eliminating the cause of overload, replace the Connector Board fuse.

REPLACEMENT AND ADJUSTMENT OF FUSE



WARNING

Be sure to use fuses meeting specified rating. Using fuses exceeding the specified rating can cause a fire or electric shock.

PART NUMBER	LOCATION	TYPE & DETAILS	QTY
514-5078-2000	WH HDF (60033UK)	2A T CERAMIC 20X5MM	2
514-5078-2000	WH HDF 60029-02UK)	2A T CERAMIC 20X5MM	4
514-5079-10000	XFMR (560-LGBH-UK)	10A T CERAMIC 32X6.3MM	1
514-5090-3000	FL UNIT (390-7001-30UK)	3A T CERAMIC 25X6.3MM	1
514-5078-5000	IEC INLET (EP1387)	5A T CERAMIC 20X5MM	1

<u>PROBLEMS</u>	<u>CASE</u>	<u>COUNTERMERMEASURES</u>
During game, graphics are displayed on the screen, but no action of left/right guns.	The guns may not be aligned correctly in TEST.	Enter GAME TEST MODE and re-align both guns and check.
The colour of image on MONITOR screen is incorrect	Incorrect monitor adjustment.	Make appropriate adjustments
The on-screen image of the monitor sways and or shrinks.	The power source and voltage are not correct.	Make sure that power supply and voltage are correct.
Sound is not emitted.	Sound Volume adjustment is not correct. Malfunctioning BD and Amp. Connector connection is incorrect.	Adjust the VTS UNIT's sound adjustment volume (control) Perform SOUND TEST. Check connector connection from IC BD to Speaker.
During game play, Controller sighting is irregular.	GUN alignment is incorrect. GUN SENSE BD. malfunctioning. ASSY MASK malfunction.	Perform GUN alignment in GAME TEST Mode. Replace GUN SENSE BD. Check optic sensors around the screen are illuminated. Change any which are faulty.
During game play, when CONTROLLERS Trigger is pulled, no shots are displayed on the screen.	Trigger SW malfunctioning. Gun harness malfunctioning.	Replace SW. Replace Gun harness.
During game play, shots are displayed on the screen but no action (shake) from one of the two guns.	Gun Shake Motor malfunction.	Replace Gun Shake Motor.
Fluorescent lamp doesn't light up.	Fluorescent lamp need replacement. Connector connection is incorrect.	Replace the Fluorescent lamp Check connector connections in the BILLBOARD.

15. GAME BOARD



- In order to prevent electric shock and short circuit hazards, be sure to turn power off before performing work.
- Be careful not to damage the wires. Damaged wires may cause electric shock or short circuit or present a fire risk.
- Do not expose the Game BD, etc. without a good reason. Failure to observe this can cause electric shock hazard or malfunctioning.
- Do not use this product with connectors other than those that were connected and used with the Game Board at the time of shipping. Do not carelessly connect wires to connectors that were not used at the time of shipping, as this may cause overheating, smoke or fire damage.
- When replacing or repairing the game board and then returning it to the cabinet, be sure to reconnect all the connectors correctly. Improper connection may cause electric shock, short circuit or fire.
- When connecting the connectors, be sure to attach them correctly. There is only one correct way in which they must be connected. Attempting to connect them incorrectly may cause damage to the pins on the connectors, and cause electric shock, short circuit or fire.



- In this product, setting changes are made during the Test Mode. The Game BD need not be operated. Use the Game BD, etc. as is with the same setting made at the time of shipment so as not to cause electric shock and malfunctioning.
- Static electricity from your body may damage some electronics devices on the IC board. Before handling the IC board, touch a grounded metallic surface so that the static electricity can be discharged.



- Do not expose the Game BD, etc. without a good reason. In this product, setting changes are made during the test mode.
- The Game BD need not be operated. Use the Game BD, etc. as is with the same setting made at the time of shipment.

15.1. REMOVING THE GAME BOARD

- ① Turn the Main SW off.
- ② Remove the Side Door from the left-hand side of the cabinet by using the Master Key and taking off the 2 screws.

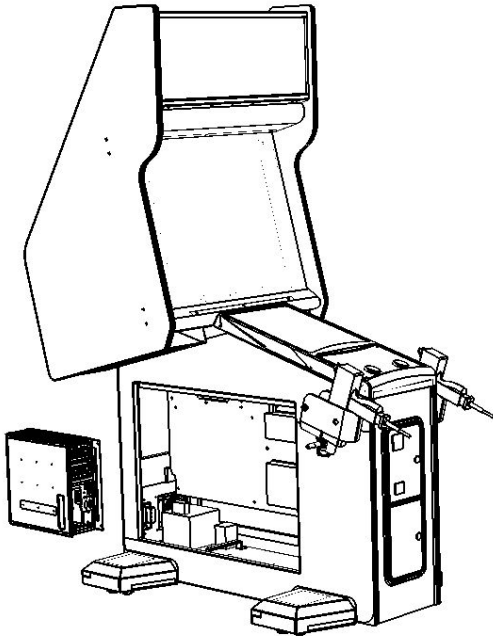
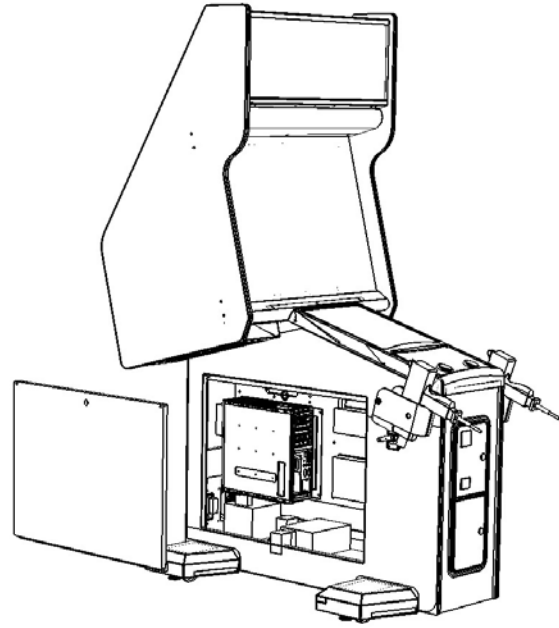

- ③ Remove all the associated harnesses then remove the 4 screws retaining the Lindbergh Game Board.

15.2. SHIPPING THE GAME BOARD



- When returning the GAME BOARD for repair or replacement, be sure to package the entire ASSY SHIELD CASE in the original card transit box - THERE ARE NO USER-SERVICEABLE PARTS INSIDE.
- Failure to return the GAME BOARD in this manner may invalidate the warranty.

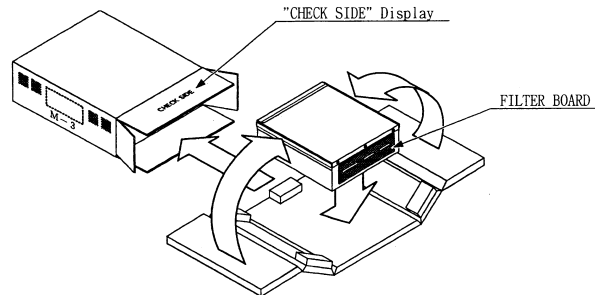

Wrap the ASSY GAME BOARD with the packaging material and put it in the original transit box as shown. Putting it upside down or packing otherwise in the manner not shown can damage the GAME BOARD and parts.

15.3. COMPOSITION OF GAME BOARD



- The game board becomes the game board for this product once the key chip is inserted.
- The DIP SW (dip switches) on the board must be set as specified below. If set incorrectly for this product, an error will be displayed and the game will not run.

ASSY CASE LBG L 1GB HDF EXP (844-0002D-02)

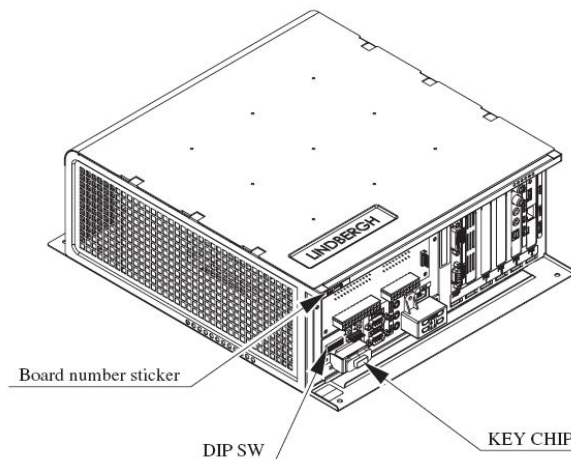

DIP SWITCH SETTINGS

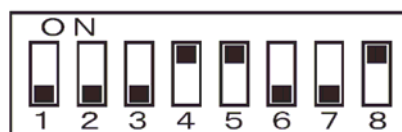

16. DESIGN RELATED PARTS

For the Warning Display stickers, refer to Section 1.



Seq. No.	Part Number	Description
****401	HDF-1072-CUK	STICKER SIDE L 02
****403	HDF-1072-EUK	STICKER SIDE R 02
***20	HDF-1502-BUK	STICKER SIDE L 01
***21	HDF-1502-DUK	STICKER SIDE R 01
***22	HDF-1513-AUK	STICKER SIDE DOOR L
***23	HDF-1513-BUK	STICKER SIDE DOOR R
***3	HDF-1055UK	BUTTON PLATE
***4	HDF-1057UK	DECAL FACIA UPPER

17. PART LIST

17.1. ASSY TOP - (HDF-00002KUK)

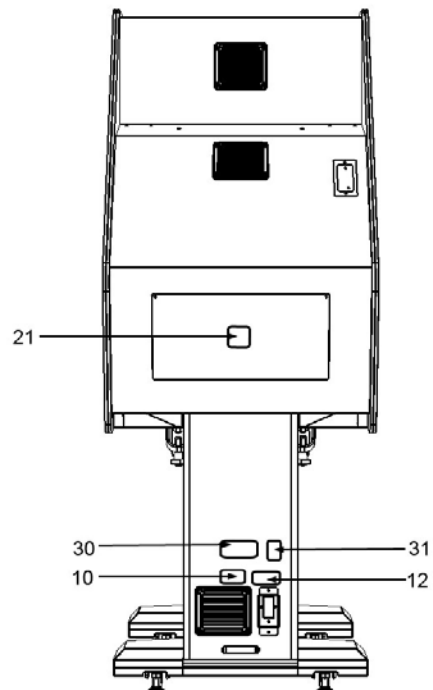
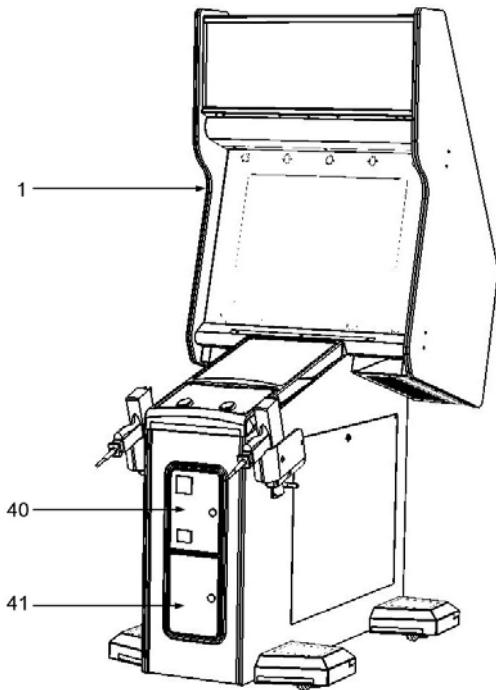

Seq. No.	Component Part	Description	Component Reference	Number off
*1	HDF-10001UK	ASSY CABINET MDX		1
*10	421-7987-HDF-M	STICKER ELEC SPEC HDF MDX	NEXT TO AC UNIT	1
*12	421-7988-91UK	STICKER SERIAL NUMBER UK	NEAR AC	1
*13	421-7020UK	STICKER CAUTION FORK		2
*16	PK0382	COVER SHRINK MDX		1
*17	PK0383	PALLET HDF MDX		1
*19	440-WS0070-EG	STICKER W PUSH GBN SD		1
*21	LB1102	STICKER DANGEROUS VOLTAGE	ON SIDE DOORS & BACK	3
*22	LB1104	STICKER CAUTION, HOT SURFACE	LIGHT BOX TOP	1
*30	LB1046	LABEL TESTED FOR ELEC. SAFETY		1
*31	LB1130	LABEL WEEE WHEELIE BIN		1
*40	220-5374-01	DOOR DFMD W/FR&LOCK C120 UNIV	(2)-1	1
*41	220-5725-05B	DOOR SINGLE MINI H.SECURTY BLK	(40)-1	1
*42	220-5574-110UK	LOCK-KEY DIFFERS-11MM W/O CAM	(41)-1	1
*400	HDF-INST-MDX	ASSY INSTALLATION KIT MDX		1

17.2. ASSY CABINET MDX – (HDF-10001UK)

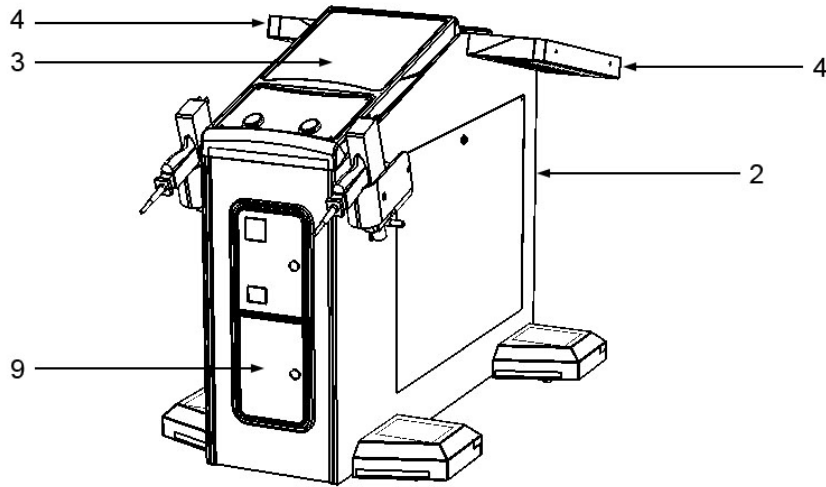

Seq. No.	Component Part	Description	Component Reference	Number off
**2	HDF-1500UK	ASSY CABINET LOWER		1
**3	HDF-1540UK	ASSY CNTRL PNL		1
**4	HDF-1095UK	ASSY LIGHT BOX		2
**9	PP1087	BOX CASH FOR MINI DOOR		1
**201	000-T00525-0B	M5X25 MSCR TH BLK	(3)-8	8
**202	000-P00616-W	M6X16 MSCR PAN W/FS PAS	(4)-2	4
**206	030-000830-SB	M8X30 BLT W/S BLK	(1)-10	10
**207	068-852216-0B	M8 WSHR 22OD FLT BLK	(1)-10	10

17.3. ASSY CABINET LOWER – (HDF-1500UK)

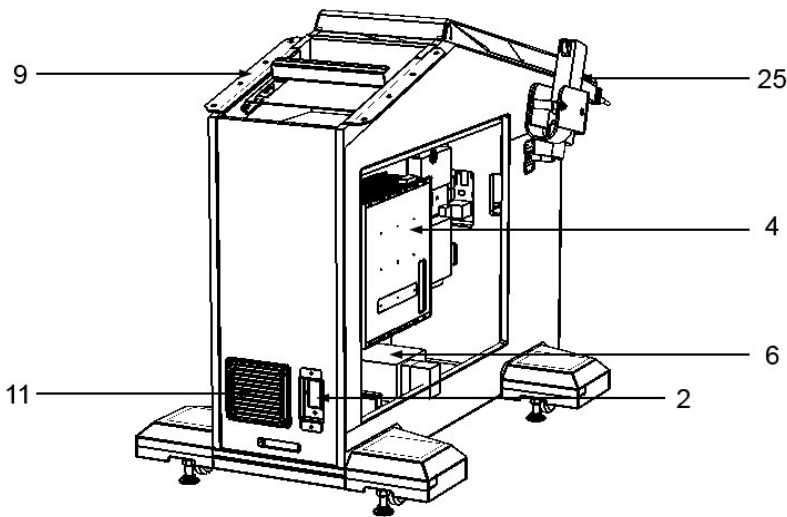
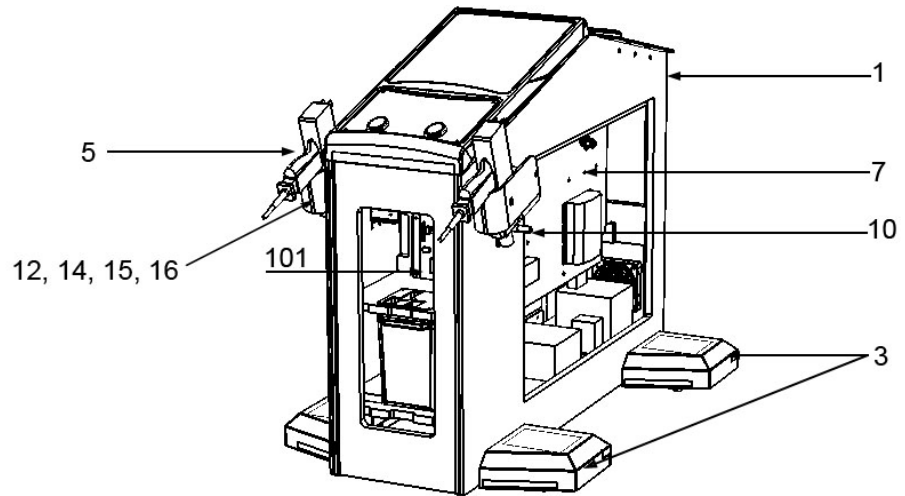

Seq. No.	Component Part	Description	Component Reference	Number off
***1	HDF-1501UK	ASSY SUB CABINET LOWER		1
***2	HDF-1530UK	ASSY AC UNIT		1
***3	HDF-1520UK	ASSY FOOT BASE		2
***4	HDF-4500UK	ASSY ELEC LEFT		1
***5	HDF-2100-02	CONTROL UNIT UK		2
***6	HDF-4700UK	ASSY POWER BASE		1
***7	HDF-4600UK	ASSY ELEC RIGHT		1
***9	HDF-1506UK	JOINT BASE		1
***10	HDF-1004UK	CONTROLLER CABLE BRKT		2
***11	HOD-1530UK	ASSY FAN UNIT UK		1
***12	HDF-1504UK	LEFT HOLSTER		1
***13	HDF-1505UK	RIGHT HOLSTER		1
***14	SPY-5104UK	GUN CUSHION A	(221)-1	2
***15	SPY-5110UK	CUSHION BAR	(221)-1	2
***16	HDF-1507UK	HOLSTER BAR SPACER	(221)-1	2
***17	DUT-0302UK	COIN PATH PLATE	NOT SHOWN	1
***18	220-5575UK	LOCK	NOT SHOWN	2
***19	253-5460-01	AIR VENT BLACK	(11)-1	1
***20	HDF-1502-BUK	STICKER SIDE L 01	NOT SHOWN	1

ASSY CABINET LOWER – (HDF-1500UK) continued

Seq. No.	Component Part	Description	Component Reference	Number off
***21	HDF-1502-DUK	STICKER SIDE R 01	NOT SHOWN	1
***22	HDF-1513-AUK	STICKER SIDE DOOR L	NOT SHOWN	1
***23	HDF-1513-BUK	STICKER SIDE DOOR R	NOT SHOWN	1
***24	ORP-2372UK	CAM CRKD 9 L34 BATON 690-ZB34	NOT SHOWN	2
***25	HDF-1511UK	TUBE CLAMP		2
***101	VTS-HOD-D	VTS BOARD HOD		1
***201	000-T00520-0B	M5X20 MSCR TH BLK	(2)-2	2
***204	000-P00430-W	M4X30 MSCR PAN W/FS PAS	(4)-2, (7)-2	4
***205	000-P00416-W	M4X16 MSCR PAN W/FS PAS	(5)-1	2
***215	030-000840-SB	M8X40 BLT W/S BLK	(3)-4, (9)-6	14
***216	068-852216-0B	M8 WSHR 22OD FLT BLK	(3)-4, (9)-6, (12)-1, (13)-1	14
***217	032-000530	M5X30 BLT WING PAS	(6)-1	1
***219	000-P00525-WB	M5X25 MSCR PAN W/FS BLK	(10)-8	8
***220	000-T00425-0B	M4X25 MSCR TH BLK	(11)-4	4
***221	029-C008C0-OB	M8X120 SKT CH BLK	(12)-1, (13)-1	2
***222	020-F00640-0B	M6X40 SKT CSK BLK	(12)-1, (13)-1	2
***223	000-P00420-W	M4X20 MSCR PAN W/FS PAS	(17)-5, (101)-4	5
***224	000-P00425-WB	M4X25 MSCR PAN W/FS BLK	(25)-2	2
***301	HDF-66017UK	WH 240V EXT	FRAME TO DOOR	1
***302	HDF-65024UK	WH VTS 62		1
***303	CTF-60019UK	WH FAN	MOUNT BRKT TO C PLAT	1

17.4. ASSY SUB CABI MONITOR – (HDF-1071UK)

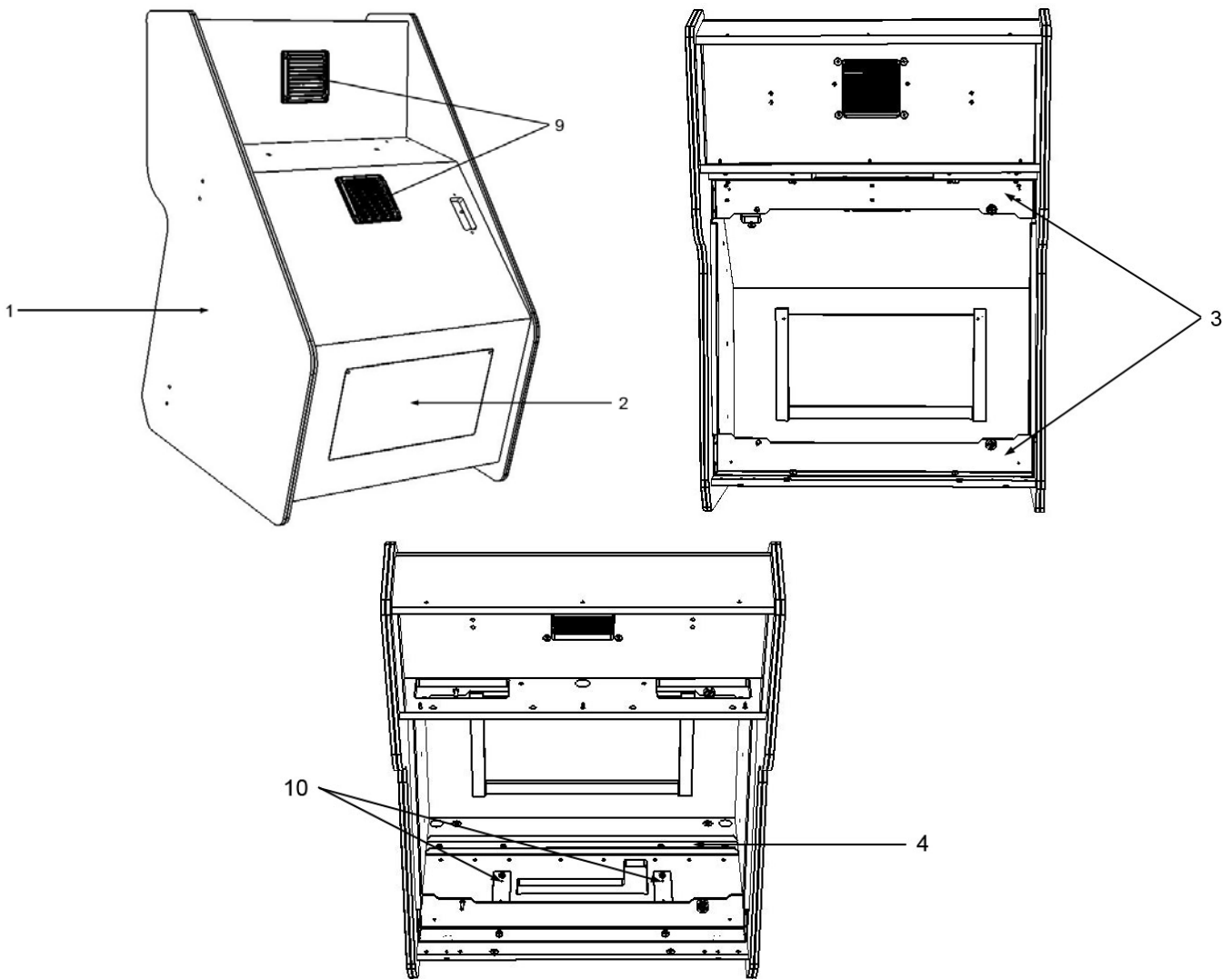

Seq. No.	Component Part	Description	Component Reference	Number off
****1	HDF-1072-AUK	MONITOR BOX BLANK UK		1
****2	GBN-1073UK	BACK DOOR		1
****3	HDF-1074UK	MONITOR SUPPORT		2
****4	GBN-1075	JOINT BEAM		1
****9	253-5460-01	VENT AIR BLACK		2
****10	HDF-1083UK	NUT PLATE		2
****12	LB1102	STICKER DANGEROUS VOLTAGE	LIGHT BOX	1
****13	LB1104	STICKER CAUTION, HOT SURFACE	LIGHT BOX	1
****201	000-T00435-0B	M4X35 MSCR TH BLK	(2)-2	2
****202	300055M	M6X30 COACH CSK BLT	(3)-8	8
****203	050-F00600	M6 NUT FLG SER PAS	(3)-8	8
****204	030-000830-S	M8X30 BLT W/S PAS	(4)-2, OUTER ONLY	2
****205	068-852216	M8 WSHR 22OD FLT PAS	(4)-2, OUTER ONLY	2
****207	000-T00420-0B	M4X20 MSCR TH BLK	(9)-8	8
****208	012-P03512-F	N6X1/2" S/TAP FLG PAS	(10)-4	4
****209	060-F00400-0B	M4 WSHR FORM A FLT BLK	(2)-2	2
****210	030-000860-SB	M8X60 BLT W/S BLK	(3)-2, TOP	2
****211	068-852216-0B	M8 WSHR 22OD FLT BLK	(3)-2, TOP	2
****401	HDF-1072-CUK	STICKER SIDE L 02		1
****403	HDF-1072-EUK	STICKER SIDE R 02		1

17.5. ASSY MONITOR UK – (HDF-1070UK)

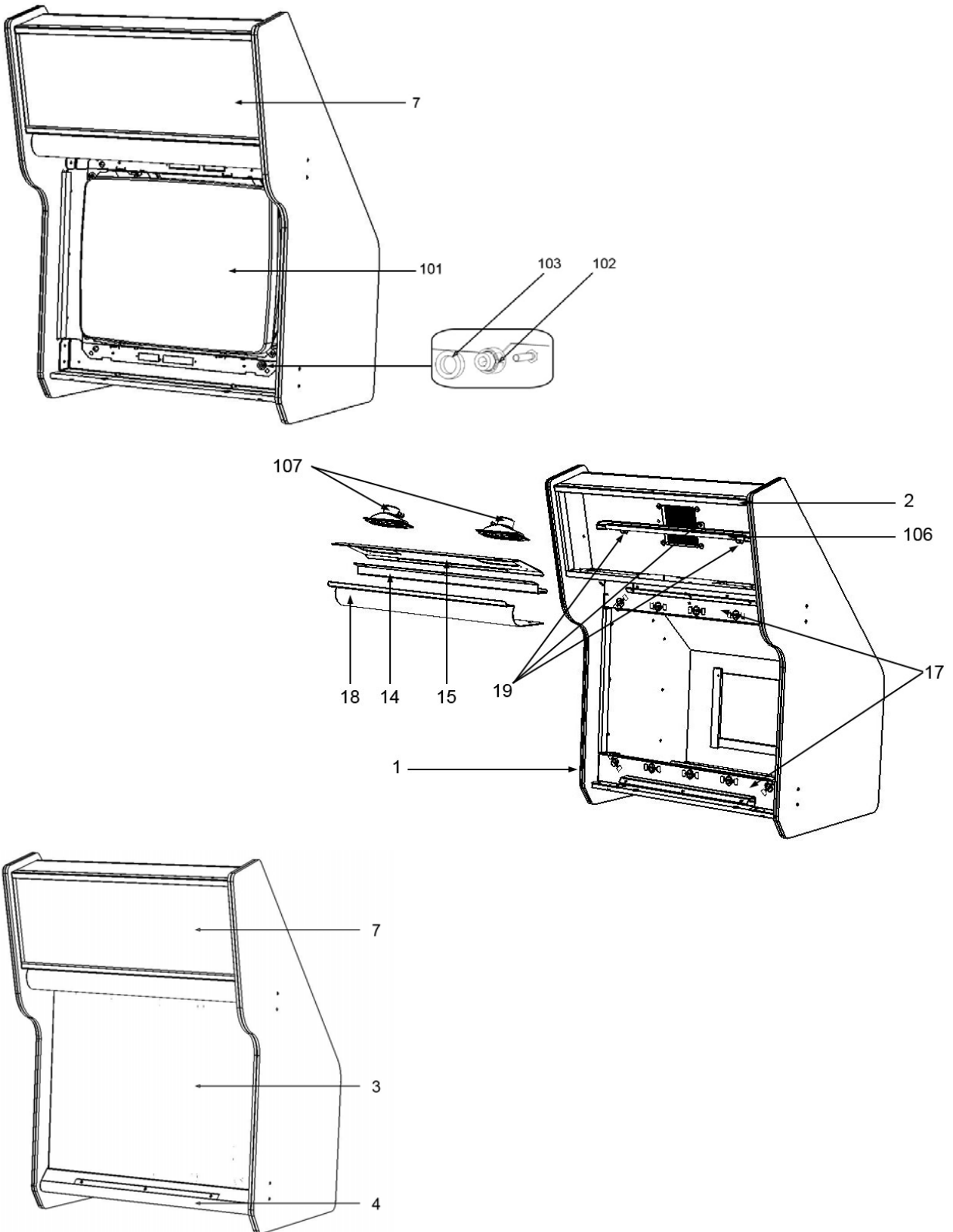

ASSY MONITOR UK – (HDF-1070UK) continued.....

Seq. No.	Component Part	Description	Component Reference	Number off
***1	HDF-1071UK	ASSY SUB CABI MONITOR		1
***2	GBN-1077	SASH UPPER		1
***3	HDF-1082UK	FRONT SCREEN		1
***4	HDF-1080UK	SCREEN RETAINER LOWER		1
***5	HDF-1081UK	ADJUST PANEL		1
***7	HDF-1079UK	BILLBOARD PLATE		1
***11	421-7501-17UK	STICKER FL20W		1
***14	HDF-1076UK	SCREEN RETAINER UPPER		1
***15	HDF-1091UK	BRKT SPKR MTG		1
***17	HDF-1085UK	ASSY SENSOR MTG		2
***18	HDF-1084UK	COVER SPEAKERS		1
***19	HDF-0457UK	BRKT FL TUBE HOLDER		3
***101	200-5949-PFX	ASSY 29 PFX TYPE 240V		1
***102	280-6643	BUSH FOR TV PF	(101)-4	4
***103	280-5113	COLLAR FOR NANA0 MONITOR	(101)-4	4
***106	390-7001-20W-UK	ASSY FL 20W T4 TUBE		1
***107	130-365-564UK	SPKR 15W 4OHM XF-365-564	(15)-2	2
***108	280-L00709-OS	STANDOFF 7OD 4ID 9L	(5)-2	2
***109	OS1230	FOAM STRIP 2mm X 10mm		3.2
***110	280-A01264-WX	ROUTER TWIST D12 SO6.4 WOOD X		14
***111	280-A02064-WX	ROUTER TWIST D20 SO6.4 WOOD X		8
***202	000-T00420-0B	M4X20 MSCR TH BLK	(2)-3, (5)-2	5
***203	000-T00425-0B	M4X25 MSCR TH BLK	(4)-6, (18)-4	10
***207	050-F00600	M6 NUT FLG SER PAS	(101)-4	4
***208	068-652516	M6 WSHR 25OD FLT PAS	(101)-4	4
***210	068-330808-PN	M3 WSHR 8OD FLT NYLON	(5)-2,BETWEEN MONITOR REMOTE & BRKT	2
***215	000-T00412-0B	M4X12 MSCR TH BLK	(4)-3, (14)-3, (18)-3	9
***216	068-441616-0B	M4 WSHR 16OD FLT BLK	(4)-3	3
***217	050-F00300	M3 NUT FLG SER PAS	MONITOR P.C.B.	2
***218	000-P00410-W	M4X10 MSCR PAN W/FS PAS	(15)-3 (19)-3, (107)-8	14
***219	050-F00400	M4 NUT FLG SER PAS	(15)-3	3
***220	068-441616	M4 WSHR 16OD FLT PAS	(15)-3	3
***221	000-T00445-0B	M4X45 MSCR TH BLK	(17)-4, TOP	4
***222	000-P00420-W	M4X20 MSCR PAN W/FS PAS	(17)-2, BOTTOM	2
***301	HDF-66015UK	WH 240V CRT		1
***302	HDF-66018UK	WH FL UNITS		1
***303	HDF-66020UK	WH SPKR B		1
***304	HDF-66021UK	WH MASK EXT 1 GB		1
***305	HDF-66022UK	WH MASK EXT 2 GB		2
***306	HDF-66023UK	WH MASK LINK GB		7
***307	600-7009-1800UK	CA VGA 1800MM		1
***308	600-9150-44K	WH EARTH 1500MM M4 M4		1
***309	600-9080-44K	WH EARTH 800MM M4 M4		2
***310	600-9120-44K	WH EARTH 1200MM M4 M4		1

17.6. ASSY SENSOR MTG – (HDF-1085UK)

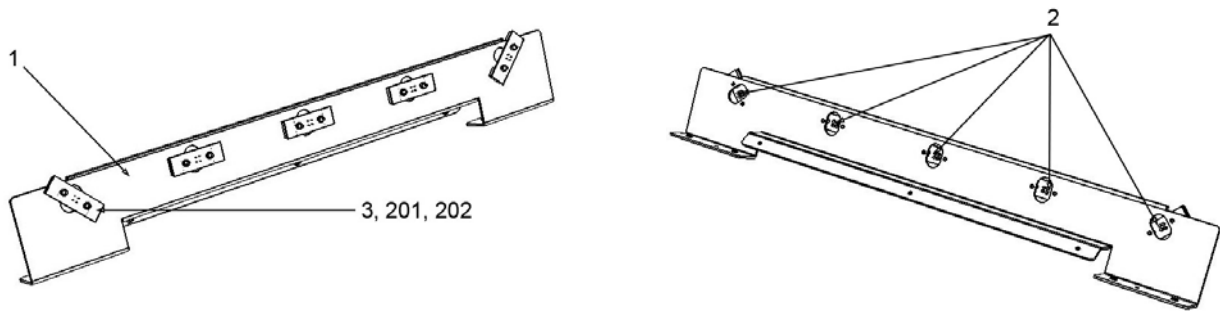

Seq. No.	Component Part	Description	Component Reference	Number off
****1	HDF-1086UK	BRKT SENSOR MTG		1
****2	JPT-1082	IR COVER		5
****3	838-13145R02	LED BD GUN SENSE HOD		5
****201	050-U00300	M3 NUT NYLOK PAS		10
****202	068-330808-PN	M3 WSHR 80D FLT NYLON		10

17.7. ASSY AC UNIT – (HDF-1530UK)

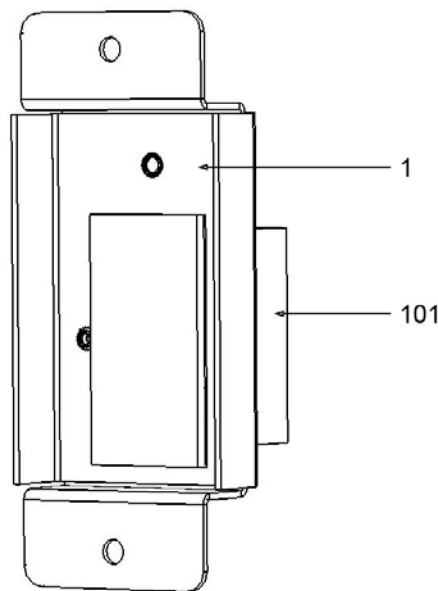

Seq. No.	Component Part	Description	Component Reference	Number off
****1	HDF-1531UK	AC BRKT		1
****3	LB1096	STICKER PROTECTIVE EARTH	NEXT TO EARTH STUD	1
****101	EP1381	FILTER IEC & SW 6A ROXBURGH	(1)-1	1
****201	000-F00316	M3X16 MSCR CSK PAS	(101)-2	2
****202	050-F00400	M4 NUT FLG SER PAS	EARTH - 1	1
****301	HDF-66013UK	WH AC BRKT		1

17.8. ASSY FOOT BASE – (HDF-1520UK)

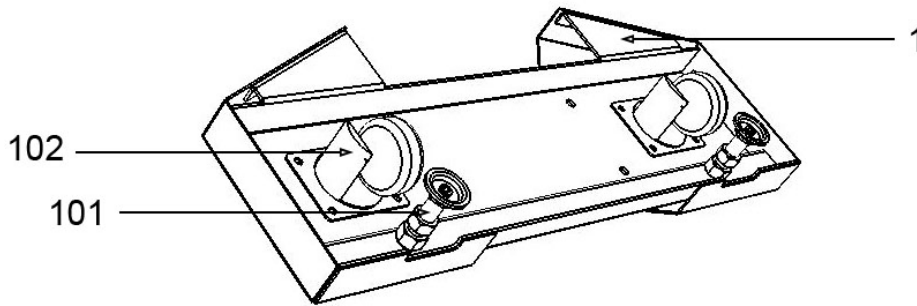

Seq. No.	Component Part	Description	Component Reference	Number off
****1	HDF-1521UK	FOOT BASE ASSY		1
****101	601-5699UK-01	LEG ADJ M16X100		2
****102	MA1019	CASTOR 75		2
****201	030-000620-S	M6X20 BLT W/S PAS	(102)-16	16
****202	060-F00600	M6 WSHR FORM A FLT PAS	(102)-16	16

17.9. ASSY FAN UNIT UK – (HDF-1530UK)

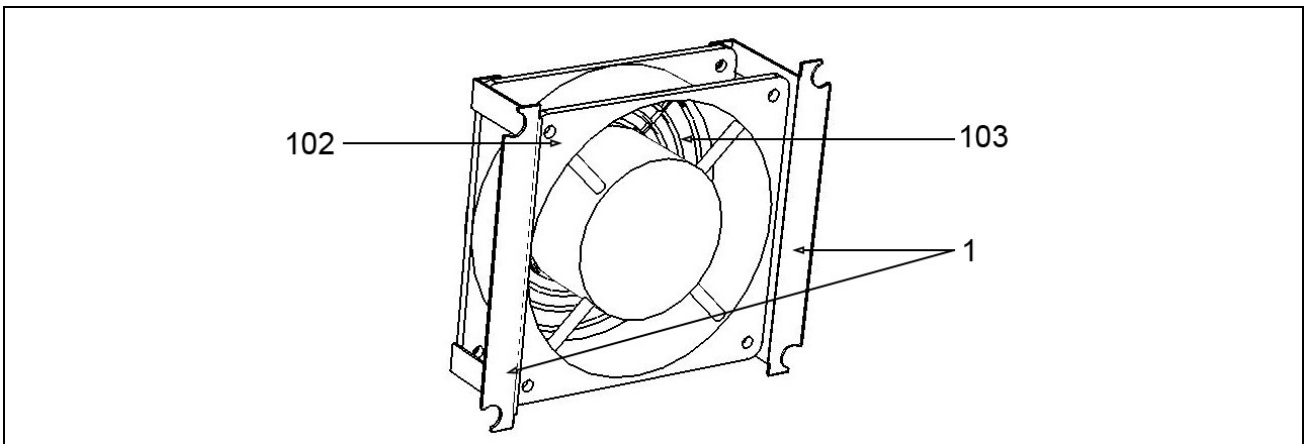

Seq. No.	Component Part	Description	Component Reference	Number off
****1	105-5340-01	FAN BRKT LONG		2
****102	260-0011-02	AXIAL FLOW FAN AC100V 50-60HZ		1
****103	FN1012	MESH GUARD METAL		1
****201	000-P00312-W	M3X12 MSCR PAN W/FS PAS		4

17.10. ASSY CONTROL PANEL – (HDF-1540UK)

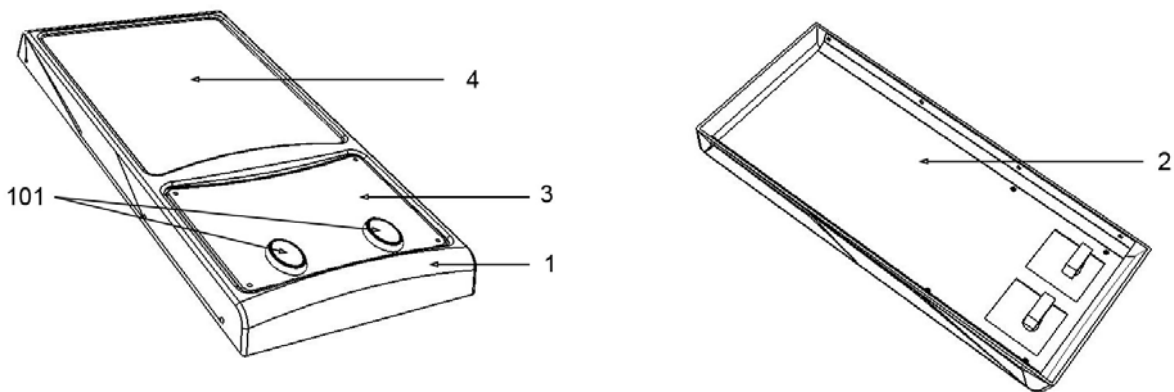

Seq. No.	Component Part	Description	Component Reference	Number off
**1	HDF-1053UK	FASCIA MOULDING LOWER CABINET		1
**2	HDF-1054UK	FASCIA SUPPORT		1
**3	HDF-1055UK	BUTTON PLATE		1
**4	HDF-1057UK	DECAL FASCIA UPPER		1
**101	509-SPYU-YE	SW PB W/LAMP 6V YELLOW OVAL		2
**102	OS1230	FOAM STRIP 2mm X 10mm	NOT SHOWN	0.3
**201	000-T00420-0B	M4X20 MSCR TH BLK	(3)-4	4
**301	HDF-66024UK	WH START SW	NOT SHOWN	1

17.11. ASSY LIGHT BOX – (HDF-1095UK)

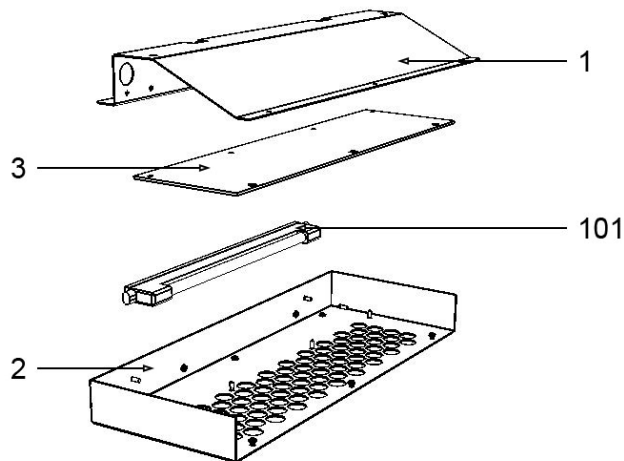

Seq. No.	Component Part	Description	Component Reference	Number off
***1	HDF-1096UK	LIGHT TRAY		1
***2	HDF-1097UK	LIGHT COVER		1
***3	HDF-1098UK	LIGHT PLATE		1
***10	LB1102	STICKER DANGEROUS VOLTAGE		1
***11	LB1104	STICKER CAUTION, HOT SURFACE		1
***101	390-7001-08-UK	ASSY FL 8W LSTR8W T4 TUBE		1
***201	000-T00412-0B	M4X12 MSCR TH BLK	(2)-6	6
***202	050-F00400	M4 NUT FLG SER PAS	(3)-4	4
***203	060-F00400	M4 WSHR FORM A FLT PAS	(3)-4	4
***204	000-F00408	M4X8 MSCR CSK PAS	(101)-2	2

17.12. ASSY POWER BASE – (HDF-4700UK)

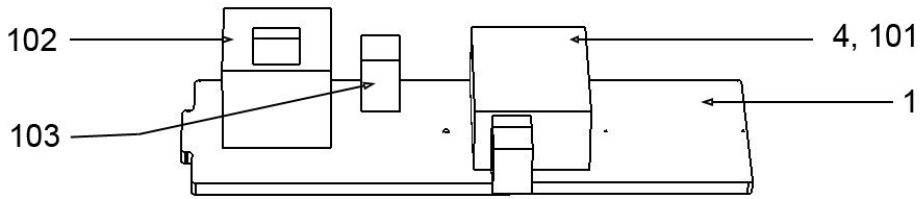

Seq. No.	Component Part	Description	Component Reference	Number off
****1	HDF-4701UK	BASE POWER		1
****4	HDF-0485UK	BRKT PWR SUPPLY	(101)-2	2
****101	400-5457-91	SW REGU ATX/JVS		1
****102	560-LBGH-01UK	XFMR LINDBURGH 230-100V 8A		1
****103	839-1160	DC TERMINAL BD		1
****104	280-A01264-WX	ROUTER TWIST D12 SO6.4 WOOD X		3
****105	280-A02064-WX	ROUTER TWIST D20 SO6.4 WOOD X		5
****106	RND-838-001	FUSE BOARD	NOT SHOWN	1
****107	OS1011	PCB FEET RICHCO LCBS-L-5-01	(106)-4	4
****201	000-P00516-W	M5X16 MSCR PAN W/FS PAS	(102)-4	4
****202	000-P00408-W	M4X8 MSCR PAN W/FS PAS	(4)-2	4
****203	000-P00416-W	M4X16 MSCR PAN W/FS PAS	(101)-4	4
****204	012-P00325	N4X1" S/TAP PAN PAS	(103)-4	4
****205	012-P03516-F	N6X5/8" S/TAP FLG PAS	(106)-4	4
****301	HDF-66014UK	WH DISTRIBUTION GB	NOT SHOWN	1
****302	HDF-66016UK	WH AC PWR BRD	NOT SHOWN	1

17.13. ASSY ELEC LEFT – (HDF-4500UK)

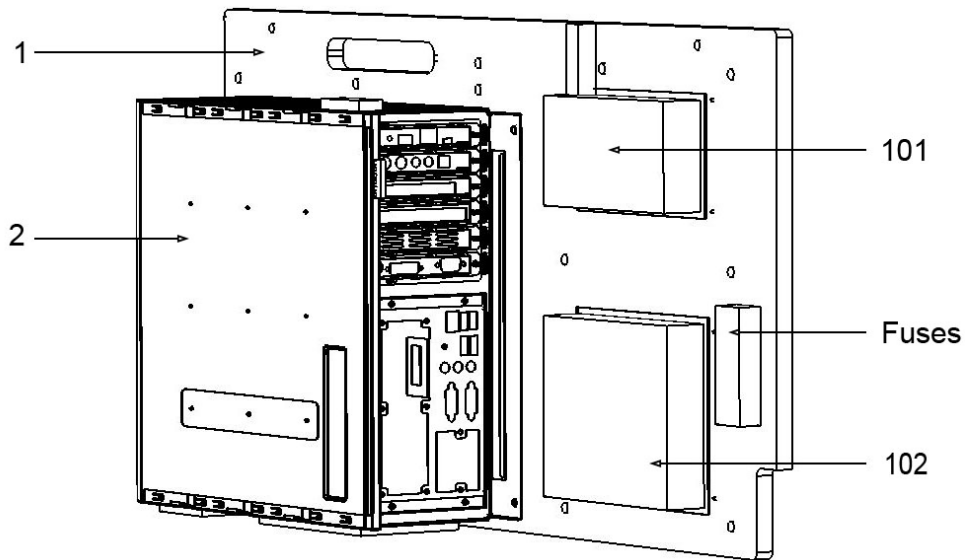

Seq. No.	Component Part	Description	Component Reference	Number off
****1	HDF-4501UK	ELEC BASE LEFT		1
****2	844-0002D-15	ASSY CASE LBG L 1GB HDF EXP2		1
****3	610-0727-0003	DVD SOFT KIT HDF		1
****101	837-14505	I/O CONTROL BD FOR JVS		1
****102	838-14465R	IC BD GUN SENCE NEW EDIT DX		1
****105	280-A01264-WX	ROUTER TWIST D12 SO6.4 WOOD X	NOT SHOWN	3
****106	280-A02064-WX	ROUTER TWIST D20 SO6.4 WOOD X	NOT SHOWN	5
****201	000-P00416-W	M4X16 MSCR PAN W/FS PAS	(2)-4	4
****202	012-P00325	N4X1" S/TAP PAN PAS	(101)-4, (102)-4	8
****301	HDF-66005UK	WH AUDIO A	NOT SHOWN	1
****302	HDF-66007UK	WH LBG PWR A	NOT SHOWN	1
****303	HDF-66008UK	WH SENSE TO MASK GB	NOT SHOWN	1
****304	HDF-66009UK	WH SENSE 1P 2P GB	NOT SHOWN	1
****305	HDF-66010UK	WH I/O GB	NOT SHOWN	1
****306	HDF-66012UK	WH DC I/O	NOT SHOWN	1
****307	HDF-60023UK	WH DVD PWR	NOT SHOWN	1
****308	CTF-60013UK	WH FREQ	NOT SHOWN	1
****309	600-7141-100UK	CA USB A - B	NOT SHOWN	1
****310	600-7920-100	CA USB MINI A/B	NOT SHOWN	1

17.14. ASSY ELEC RIGHT – (HDF-4600UK)

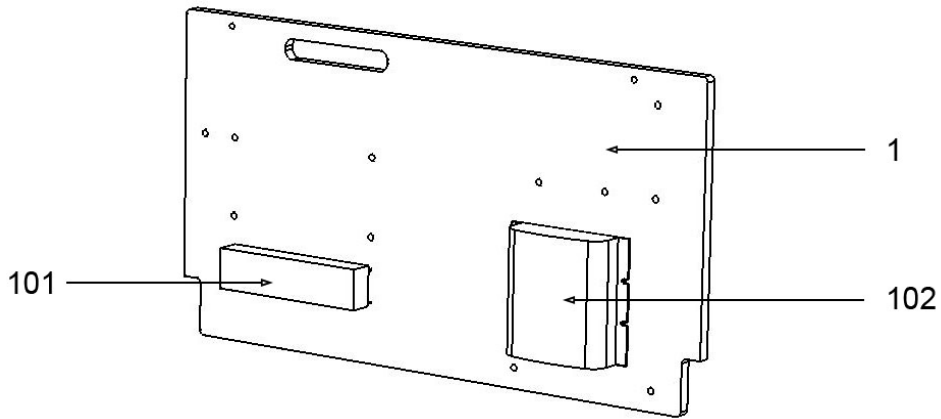

Seq. No.	Component Part	Description	Component Reference	Number off
****1	HDF-4601UK	ELEC BASE RIGHT		1
****101	400-5421-05012	SW REGU LCA50S-12		1
****102	838-CA-150	AMP 2 CH 12V CIE CA-150/S		1
****103	OS1011	PCB FEET RICHCO LCBS-L-5-01	(101)-4	4
****104	280-A01264-WX	ROUTER TWIST D12 SO6.4 WOOD X		10
****201	012-P03516-F	N6X5/8" S/TAP FLG PAS	(202)-4, (102)-4	8
****301	HDF-66001UK	WH 100V SW REGU		1
****302	HDF-66002UK	WH DC PWR		1
****303	HDF-66003UK	WH SPKR A		1
****304	HDF-66004UK	WH VOL EXT A		1
****305	HDF-66006UK	WH AMP PWR		1
****306	HDF-66011UK	WH AUDIO B		1

17.15. ASSY INSTALLATION KIT MDX – (HDF-INST-MDX)

Seq. No.	Component Part	Description	Component Reference	Number off
**1	440-CS0186UK	STICKER C EPILEPSY MULTI		1
**2	SAECE-XXX	DECLARATION OF CONFORMITY		1
**3	HDF-1056UK	DECAL BUTTON PLATE HDF MDX MULTI		1
**4	540-0043-91	L-WRENCH FOR HEX SOC 3MM		1
**20	601-11691	CARTON BOX LBG		1
**401	OS1019	SELF SEAL BAG 9X12.3/4		2
**402	420-6908-03UK	SERVICE MANUAL HDF MDX		1
**404	350-5801	MOTOR DC5V TG-01H		2
**405	509-5080	SW MICRO TYPE (SS-5GL2)		2

18. WIRE COLOUR CODE TABLE

THE WIRE COLOUR CODE IS AS FOLLOWS:

A	PINK
B	SKY BLUE
C	BROWN
D	PURPLE
E	LIGHT GREEN

Wires other than those of any of the colours listed above will be displayed by 2 alphanumeric characters:

1	RED
2	BLUE
3	YELLOW
4	GREEN
5	WHITE
7	ORANGE
8	BLACK
9	GREY

If the right hand side numeral of the code is 0, then the wire will be of a single colour shown by the left hand side numeral (see the list above).

Note 1: If the right hand side alphanumeric is not 0, that particular wire has a spiral colour code. The left hand side character shows the base colour and the right hand side one, the spiral colour.

[Example] 51----- WHITE/RED = WHITE wire with RED stripes

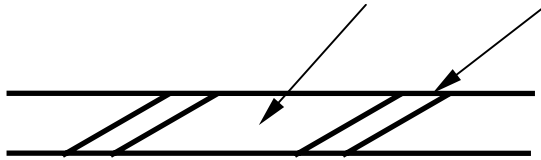

Note 2: The character following the wire colour code indicates the size of the wire.

K:	AWG18, UL1015
L:	AWG20, UL1007
None	AWG22, UL1007

19. APPENDIX A - ELECTRICAL SCHEMATIC

The following page contains the electrical schematic for this machine.

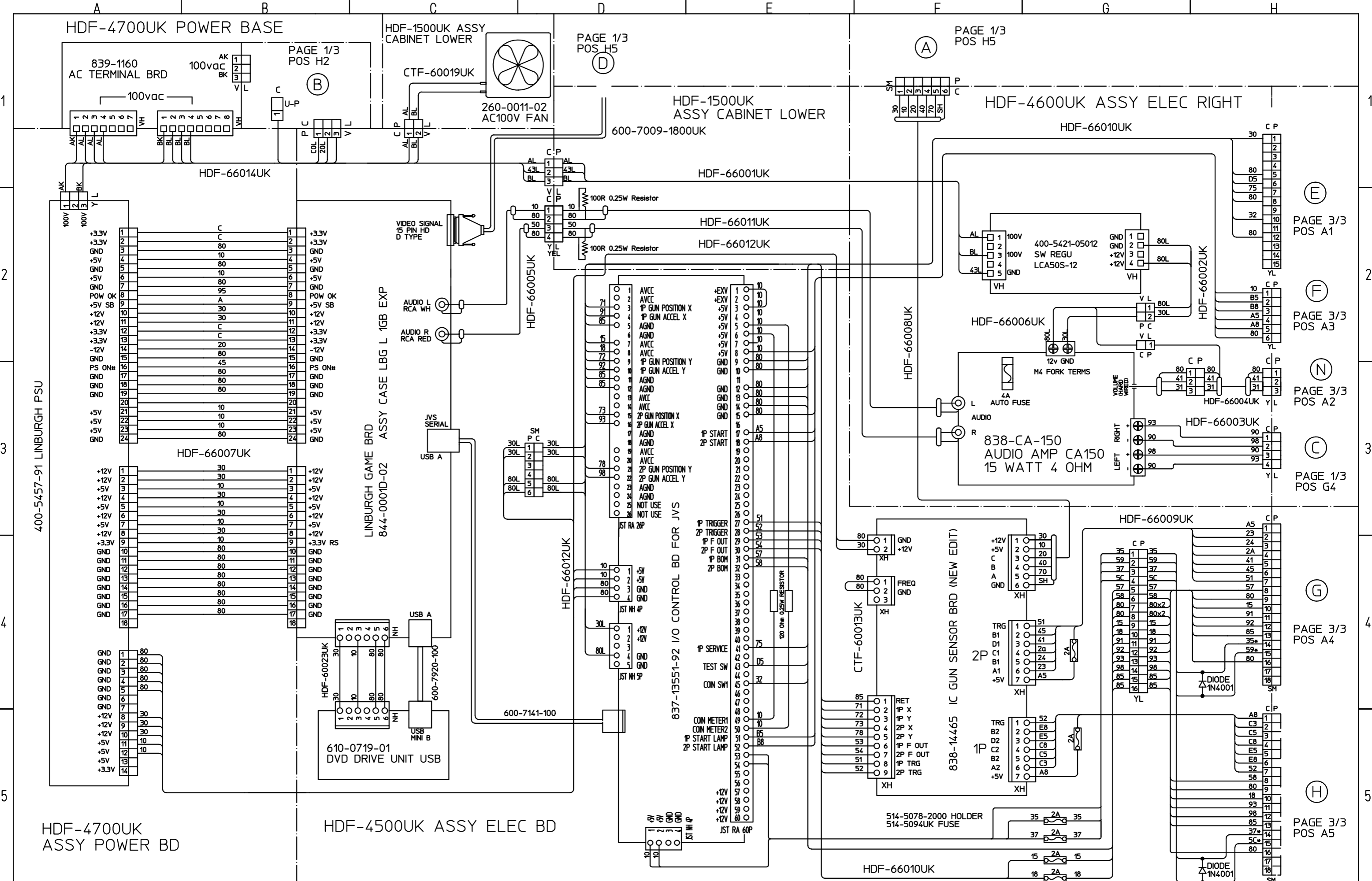

1	RED	8	BLACK	F	LIGHT GREEN
2	BLUE	9	GREY		
3	YELLOW	A	PINK		
4	GREEN	B	SKY BLUE	U	AWG 16 UL105
5	WHITE	C	BROWN	K	AWG 18 UL105
6				L	AWG 20 UL1007
7	ORANGE	D	PURPLE		AWG 22 UL1007

DRAWN	CHKD	TOP LEVEL
CW		
28/12/05		

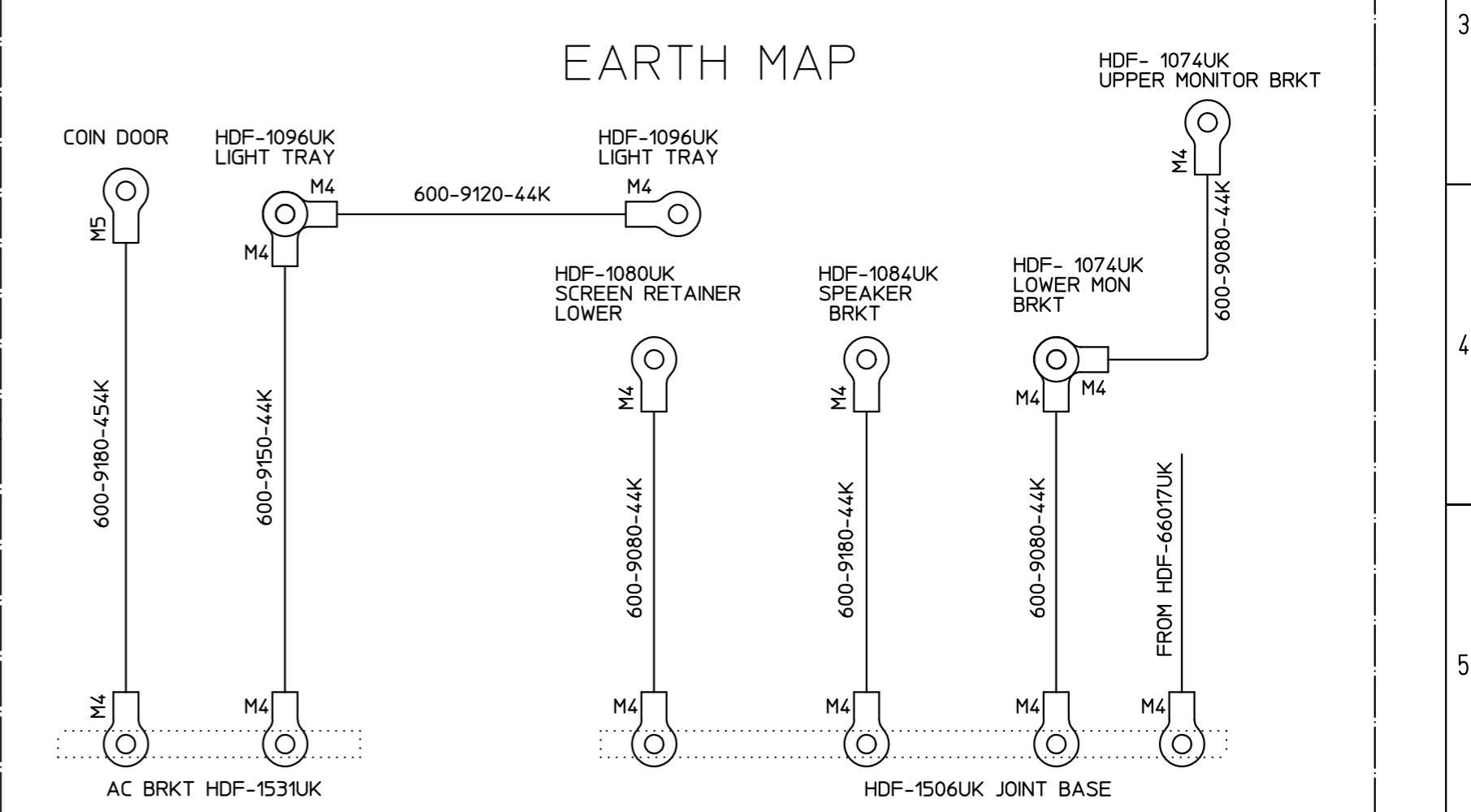
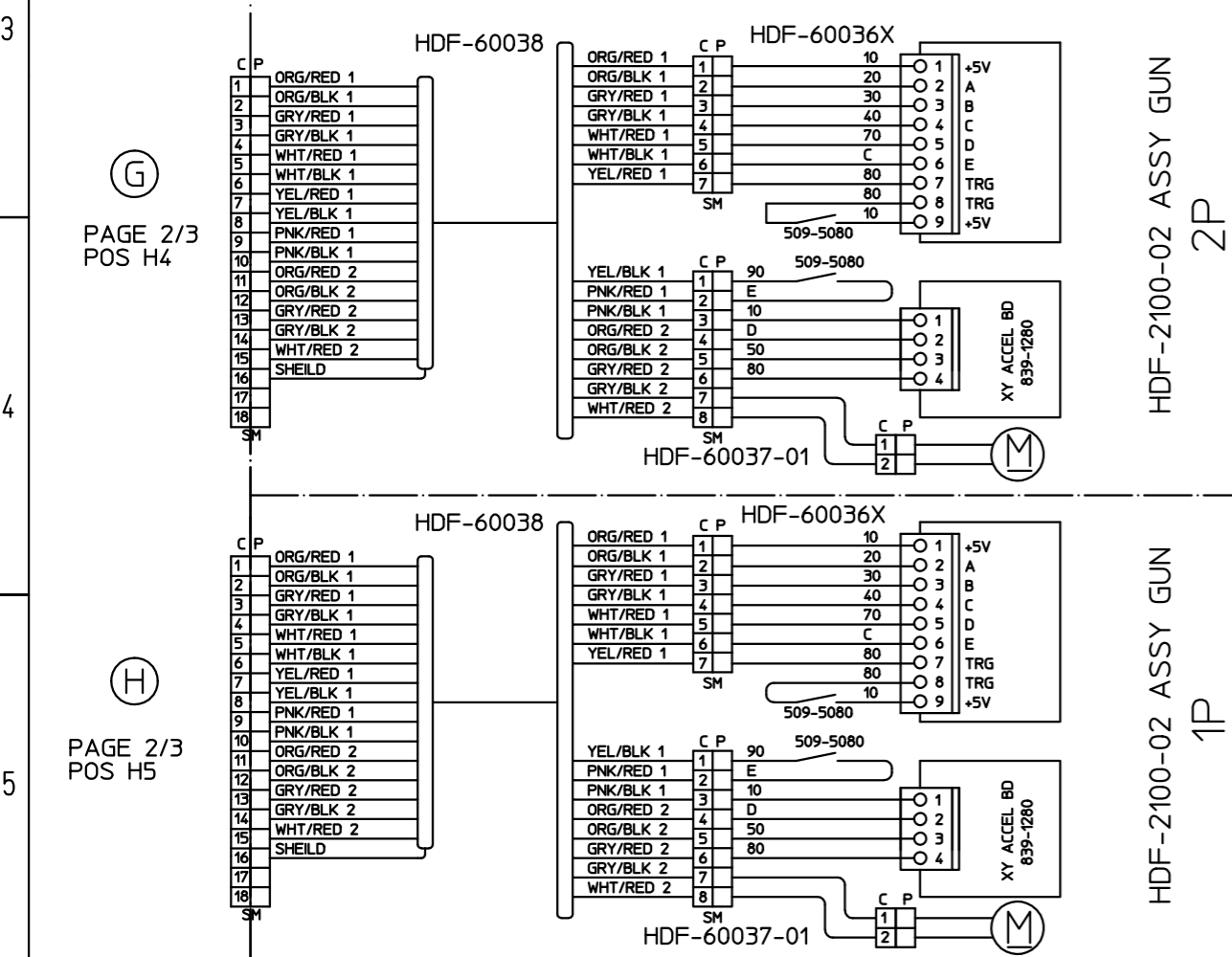
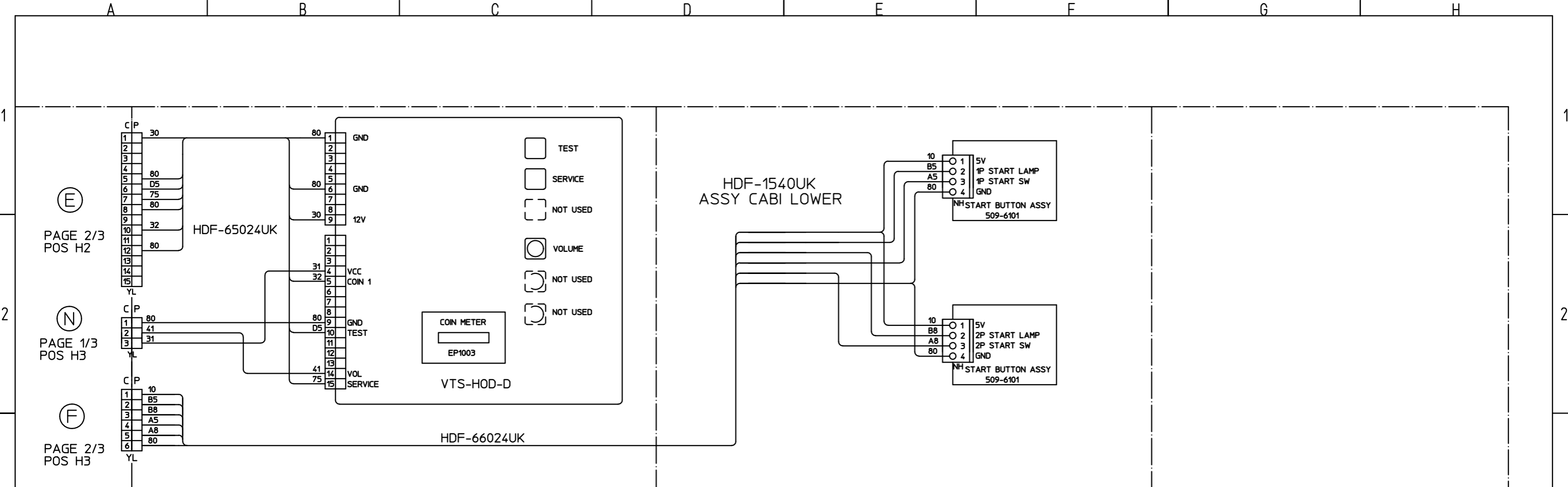

ALTERATIONS		COLOUR CODE		WIRE TYPE		28/12/05	DESCRIPTION	PART NO.
1	RED	8	BLACK	F	LIGHT GREEN			
2	BLUE	9	GREY					
3	YELLOW	A	PINK			U	AWG 16 UL105	
4	GREEN	B	SKY BLUE			K	AWG 18 UL105	
5	WHITE	C	BROWN			L	AWG 20 UL1007	
7	ORANGE	D	PURPLE				AWG 22 UL1007	

DRAWN	CHKD	TOP LEVEL	SEGA	SEGA AMUSEMENTS EUROPE, LTD.	THIS DRAWING WILL IN NO WAY BE COPIED, TO BE RETURNED ON DEMAND.	ORIGINAL SIZE
CW						A3
HOUSE OF THE DEAD 4 (MINI DLX)						HDF MDX 3/3

SEGA AMUSEMENTS EUROPE

Suite 3a Oak House,
12-22 West Street
Epsom
Surrey
United Kingdom,
KT18 7RG.

Telephone: +44 (0) 1372 731 820

Fax: +44 (0) 1372 731 849



© SEGA 2006