



SEGA CORPORATION

Nissay Aroma Building, 5-37-1, Kamata, Ohta-ku, Tokyo 144-8721, Japan
Phone: +81-3-5480-6582 Facsimile: +81-3-5480-6584

© SEGA

2SPICY

OWNER'S MANUAL

420-7031-01



OWNER'S MANUAL



IMPORTANT

- Before using this product, read this manual carefully to understand the contents herein stated.
- After reading this manual, be sure to keep it near the product or in a convenient place for easy reference when necessary.

TABLE OF CONTENTS

BEFORE USING THE PRODUCT, BE SURE TO READ THE FOLLOWING:

TABLE OF CONTENTS	i
INTRODUCTION	iii
1 HANDLING PRECAUTIONS	1
2 PRECAUTIONS REGARDING INSTALLATION LOCATION	4
2-1 LIMITATIONS OF USAGE	4
2-2 OPERATION AREA	6
3 PRECAUTIONS REGARDING PRODUCT OPERATION	7
3-1 BEFORE OPERATION	7
3-2 DURING OPERATION (PAYING ATTENTION TO CUSTOMERS)	9
4 PART DESCRIPTIONS	10
5 ACCESSORIES	11
6 ASSEMBLY AND INSTALLATION	13
7 PRECAUTIONS WHEN MOVING THE MACHINE	37
8 GAME DESCRIPTION	39
9 EXPLANATION OF TEST AND DATA DISPLAY	52
9-1 SWITCH UNIT AND COIN METER	54
9-2 SYSTEM TEST MODE	55
9-3 GAME TEST MODE	56
10 CONTROL UNIT (GUN)	67
11 MONITOR (LCD DISPLAY)	72
11-1 SAFETY PRECAUTIONS WHEN HANDLING THE MONITOR	72
11-2 CLEANING THE SCREEN SURFACE	73
11-3 ADJUSTMENT METHOD	74
12 COIN SELECTOR	77
13 FLUORESCENT LAMP REPLACEMENT	79
14 PERIODIC INSPECTION	82
15 TROUBLESHOOTING	84
15-1 TROUBLESHOOTING TABLE	84
15-2 FUSE REPLACEMENT	86
15-3 ERROR DISPLAY	87

16 GAME BOARD 91
 16-1 REMOVING THE LINDBERGH RED92
 16-2 COMPOSITION OF THE GAME BOARD94

17 DESIGN-RELATED PARTS..... 95

18 PARTS LIST 96

19 WIRE COLOR CODE TABLE 142

20 WIRING DIAGRAM..... 143

INTRODUCTION

This manual is intended to provide detailed descriptions together with all the necessary information covering the general operation of electronic assemblies, electro-mechanicals, servicing control, spare parts, etc. for the product, "2SPICY."

This manual is intended for the owners, personnel and managers in charge of operation of the product. Operate the product after carefully reading and sufficiently understanding the instructions.

In the unlikely event that the product does not function correctly, DO NOT allow anyone other than a technician to touch the internal system. Turn off the power to the machine, making sure to unplug the electrical cord from the outlet, and contact the office listed below or the point of purchase for this product.

Use of this product is unlikely to cause physical injuries or damage to property. However, points that require special attention are indicated by bold text, the word "IMPORTANT" and the symbol below.



Indicates important information that, if ignored, may result in the mishandling of the product and cause faulty operation or damage to the product.

Sega Amusements U.S.A., Inc.

800 Arthur Avenue, Elk Grove Village, IL 60007-5215, U.S.A.

TEL: 1-847-364-9787
 TOLL FREE: 1-888-877-2669
 FAX: 1-847-427-1065

SEGA AMUSEMENTS EUROPE, LTD.

Suite 3a, Oaks House 12-22, West Street, Epsom, Surrey, KT18 7RG, United Kingdom

Telephone: +44 (0) 1372 731820 Facsimile: +44 (0) 1372 731849
 e-mail: mailbox@sega.co.uk <http://www.sega-amusements.co.uk>

SPECIFICATIONS	
Installation space:	
Width:	865.5 mm (34.1 in.)
Depth:	1,664 mm (65.5 in.) <Recommended> 1,290 mm (50.8 in.) <Minimum>
Height:	2,176 mm (85.7 in.)
Weight:	Front Cabinet: 128 kg (282.2 lbs) (Including billboard) Rear Cabinet: 63 kg (138.9 lbs) (Including pedal unit)
Power, maximum current:	470 W, 2.7 A (AC 220 V, 50 Hz Area) 440 W, 2.6 A (AC 220 V, 60 Hz Area) 470 W, 2.6 A (AC 240 V, 50 Hz Area)
Power, current:	445 W, 5.18 A, (Max.) (AC 110 V, 60 Hz; Taiwan) 343 W, 4.05 A, (Min.) (AC 110 V, 60 Hz; Taiwan)
Monitor:	32 Type LCD Monitor

NOTE: The contents herein described are subject to change without notice.

Definition of 'Site Maintenance Personnel or Other Qualified Individuals' **WARNING**

Procedures not described in this manual or marked as 'to be carried out by site maintenance personnel or other qualified professionals' should not be carried out by personnel without the necessary skill or technology. Work carried out by unqualified persons may cause serious accidents, including electrocution.

Parts replacement, maintenance inspections and troubleshooting should be carried out by site maintenance personnel or other qualified professionals. This manual includes directions for potentially dangerous procedures which should only be carried out by professionals with the appropriate specialized knowledge.

The site maintenance personnel or other qualified professionals mentioned in this manual are defined as follows:

Site maintenance personnel:

Individuals with experience in maintaining amusement equipment, vending machines, etc., working under the supervision of the owner/operator of this product to maintain machines within amusement facilities or similar premises by carrying out everyday procedures such as assembly, maintenance inspections, and replacement of units/expendable parts.

Activities to be carried out by site maintenance personnel:

Amusement equipment/vending machine assembly, maintenance inspection and replacement of units/expendable parts.

Other qualified professionals:

Persons employed by amusement equipment manufacturers, or involved in design, production, testing or maintenance of amusement equipment. The individual should have either graduated from technical school or hold similar qualifications in electrical/electronics/mechanical engineering.

Activities to be carried out by other qualified professionals:

Amusement equipment/vending machine assembly, repair/adjustment of electrical/electronic/mechanical parts.

1 HANDLING PRECAUTIONS

When installing or inspecting the machine, be very careful of the following points and pay attention to ensure that the player can enjoy the game safely.

Non-compliance with the following points or inappropriate handling running counter to the cautionary matters herein stated can cause personal injury or damage to the machine.

WARNING

- Before performing work, be sure to turn the power off. Performing the work without turning the power off can cause an electric shock or short circuit. In the case work should be performed in the status of power on, this manual always states to that effect.
- To avoid an electric shock or short circuit, do not plug in or unplug quickly.
- To avoid an electric shock, do not plug in or unplug with a wet hand.
- Do not expose power cords or earth wires on the surface, (floor, passage, etc.). If exposed, the power cords and earth wires are susceptible to damage. Damaged cords and wires can cause an electric shock or short circuit.
- To avoid causing a fire or an electric shock, do not put things on or damage the power cords.
- When or after installing the product, do not unnecessarily pull the power cord. If damaged, the power cord can cause a fire or an electric shock.
- In case the power cord is damaged, ask for a replacement through where the product was purchased from or the office herein stated. Using the cord as is damaged can cause fire, an electric shock or leakage.
- Be sure to perform grounding appropriately. Inappropriate grounding can cause an electric shock.
- Be sure to use fuses meeting the specified rating. Using fuses exceeding the specified rating can cause a fire or an electric shock.
- Be sure that connections such as IC BD are made properly. Insufficient insertion can cause an electric shock.
- Specification changes, removal of equipment, conversion and/or addition, not designated by SEGA are not permitted.
 - Failure to observe this may cause a fire or an electric shock. Non-compliance with this instruction can have a bad influence upon physical conditions of the players or the onlookers, or result in injury during play.
 - SEGA shall not be held responsible for damage, compensation for damage to a third party, caused by specification changes not designated by SEGA.
- If work or parts replacement not indicated in this manual is carried out, an accident may occur. If it is necessary to carry out work not indicated in this manual, be sure to have it done by the office indicated in this manual or by the point of purchase. Also, please inquire regarding details of the work involved.
- Be sure to perform periodic maintenance inspections herein stated.

STOP IMPORTANT

- For the IC board circuit inspections, only the logic tester is allowed. The use of a multiple-purpose tester is not permitted, so be careful in this regard.
- Static electricity from your body may damage some electronics devices on the IC board. Before handling the IC board, touch a grounded metallic surface so that the static electricity can be discharged.
- Do not turn the power on and off continuously. Repeatedly turning the power on and off may cause product malfunction or parts damage.
- Some parts are not designed and manufactured specifically for this game machine. The manufacturers may discontinue, or change the specifications of such general-purpose parts. If this is the case, SEGA cannot repair or replace a failed game machine whether or not a warranty period has expired.

CONCERNING THE STICKER DISPLAY

This SEGA product has stickers attached describing the product manufacture No. (Serial No.) and Electrical Specifications. It also has a Sticker describing where to contact for repair and for purchasing parts. When inquiring about or asking for repairs, mention the Serial No. and Name of Machine indicated on the Sticker. The Serial Number indicates the product register. Identical machines could have different parts depending on the date of production. Also, improvements and modifications might have been made after the publication of this manual. In order to ensure you order the correct parts, mention the Serial No. when contacting the applicable places.

CONCERNING WARNING DISPLAYS

This SEGA product has warning displays on stickers, labels and/or printed instructions adhered/attached to or incorporated in the places where a potentially hazardous situation could arise. The warning displays are intended for accident prevention for customers and for avoiding hazardous situations relating to maintenance and servicing work. Some portions of the cabinet contain high voltage and may cause accidents if touched. When performing maintenance, be very careful of the warning displays. It is especially important that any complex repair and replacement work not mentioned herein should be performed by those technical personnel who have knowledge of electricity and technical expertise. In order to prevent accidents, caution any customer ignoring the warnings to cease and desist immediately.

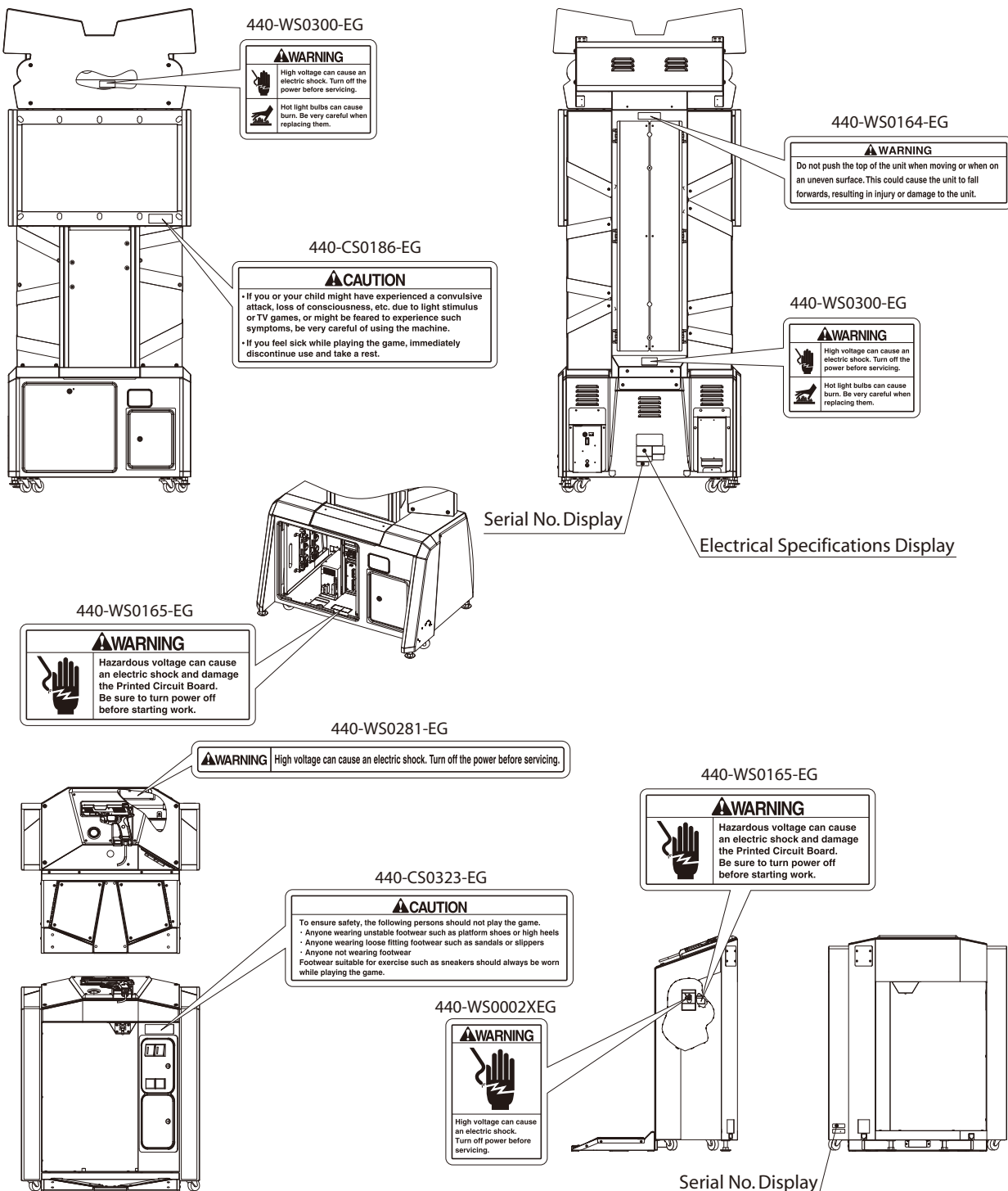

2 PRECAUTIONS REGARDING INSTALLATION LOCATION

WARNING

This product is an indoor game machine. Do not install it outside. Even indoors, avoid installing in places mentioned below so as not to cause a fire, electric shock, injury and/or malfunction.

- Places subject to rain or water leakage, or places subject to high humidity in the proximity of an indoor swimming pool and/or shower, etc.
- Places subject to direct sunlight, or places subject to high temperatures in the proximity of heating units, etc.
- Places filled with inflammable gas or vicinity of highly inflammable/volatile chemicals or hazardous matter.
- Dusty places.
- Sloped surfaces.
- Places subject to any type of violent impact.
- Vicinity of anti-disaster facilities such as fire exits and fire extinguishers.
- Areas where the temperature exceeds the applicable temperature (ambient temperature) range of 5 to 30 degrees centigrade.

2-1 LIMITATIONS OF USAGE

WARNING

- Be sure to check the Electrical Specifications. Ensure that this product is compatible with the location's power supply, voltage, and frequency requirements. A plate describing Electrical Specifications is attached to the product. Non-compliance with the Electrical Specifications can cause a fire and electric shock.
- This product requires a breaker and earth mechanism as part of the location facilities. Using the product without these can cause a fire and electric shock.
- Ensure that the indoor wiring for the power supply is rated at 15 A or higher (AC single phase 100 V ~ 120 V area), and 7 A or higher (AC 220 V ~ 240 V area). Non-compliance with the Electrical Specifications can cause a fire and electric shock.
- Be sure to use an independent power supply equipped with an earth leakage breaker. Using a power supply without an earth leakage breaker can cause an outbreak of fire if a power surge occurs.
- Putting many loads on one electrical outlet can cause generation of heat and a fire resulting from overload.
- When using an extension cord, ensure that the cord is rated at 15 A or higher (AC 100 V ~ 120 V area) and 7 A or higher (AC 220 V ~ 240 V area). Using a cord rated lower than the specified rating can cause a fire and electric shock.

Electricity Consumption:

MAX. 2.7 A	(AC 220 V, 50 Hz)
MAX. 2.6 A	(AC 220 V, 60 Hz)
MAX. 2.6 A	(AC 240 V, 50 Hz)
MAX. 5.18 A	(AC 110 V, 60 Hz) <TAIWAN>

2-2 OPERATION AREA

⚠ WARNING

- For the operation of this machine, secure a minimum area of 1.5 m (4.9 ft) [W] x 2.4 m (7.9 ft) [D]. The dimensions of the base periphery are established in consideration of ventilation, maintenance and customer passage. And if they fall and hit their head, there could be a very serious injury. Be sure to always secure enough space as prescribed in this manual.
- Be sure to provide sufficient space specified in this manual. Do not allow objects to block the ventilation ports. It can cause generation of heat and a fire.
- SEGA shall not be held responsible for damage or compensation for damage to a third party, resulting from the failure to observe this instruction.

STOP IMPORTANT

In order to transport the machine into a building, the minimum necessary dimensions of the opening (of doors, etc.) are 0.8 m (2.7 ft) [W] and 1.8 m (5.9 ft) [H].

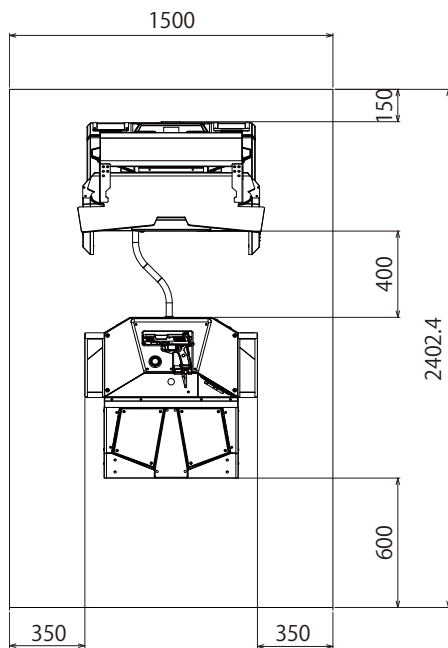

FIG. 2-2a
Recommended installation dimensions

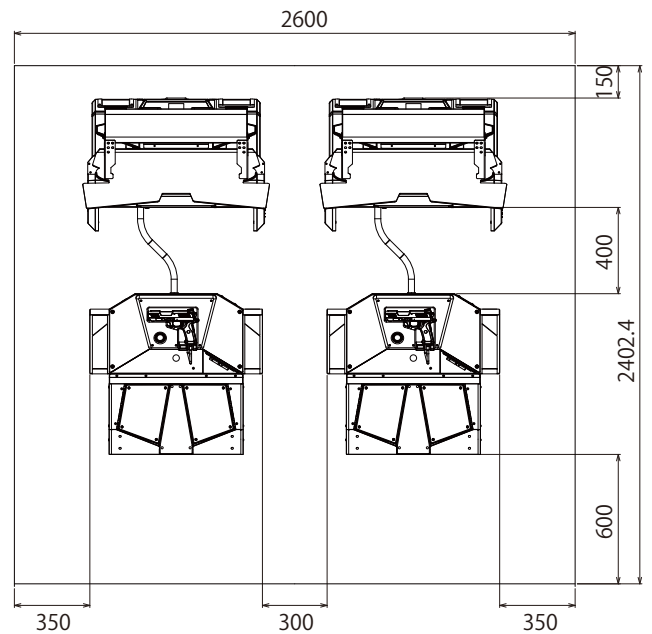

FIG. 2-2b
(Ref.) Recommended installation dimensions for two units used for competitive play

3 PRECAUTIONS REGARDING PRODUCT OPERATION

To avoid injury and trouble, be sure to pay attention to the behavior of visitors and players.

3-1 BEFORE OPERATION

WARNING

In order to avoid accidents, check the following before starting the operation:

- To ensure maximum safety for the players and the customers, ensure that where the product is operated has sufficient lighting to allow any warnings to be read. Operation under insufficient lighting can cause bodily contact with each other, hitting accident, and/or trouble between customers.
- Be sure to perform appropriate adjustment of the monitor (projector). For operation of this machine, do not leave monitor's flickering or deviation as is. Failure to observe this can have a bad influence upon the players' or the customers' physical conditions.
- It is suggested to ensure a space allowing the players who feel sick while playing the game to take a rest.
- Check if all of the adjusters are in contact with the surface. If they are not, the cabinet can move and cause an accident.

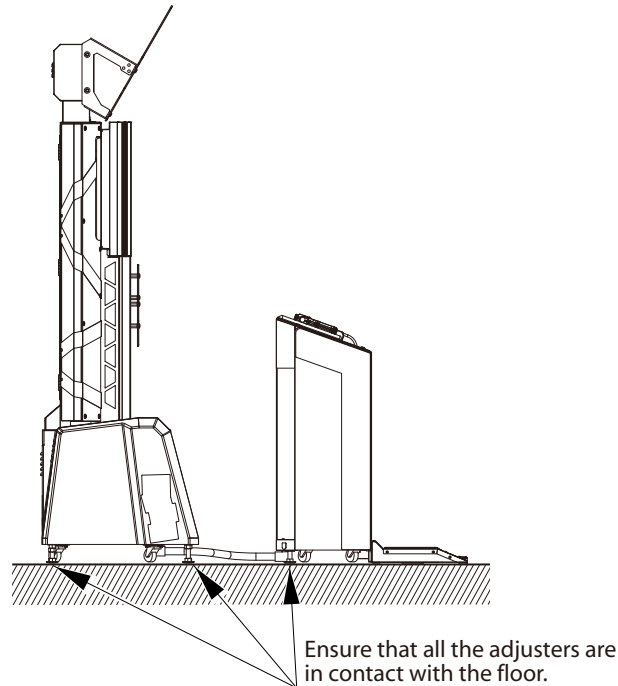

- Do not put any heavy item on this product. Placing any heavy item on the product can cause a falling down accident or parts damage.
- Do not climb on the product. Climbing on the product can cause falling down accidents. To check the top portion of the product, use a step ladder.
- To avoid electric shock, check to see if door & cover parts are damaged or omitted.
- To avoid electric shock, short circuit and/or parts damage, do not put the following items on or in the periphery of the product.
Flower vases, flowerpots, cups, water tanks, cosmetics, and receptacles/containers/vessels containing chemicals and water.

CAUTION

- To avoid injury, be sure to provide sufficient space by considering the potentially crowded situation at the installation location. Insufficient installation space can cause contact, collisions, and/or trouble between customers.
- Every day when cleaning the gun, inspect the gun and make sure that there are no scratches or cracks in the surface, and that the fastening screws are not loose. If the game is played with scratches, cracks or loose screws, it can cause injuries to the player or to people nearby.

Ensure that the screws are not loose and are all present.

Ensure that the casing is free of scratches and cracks.

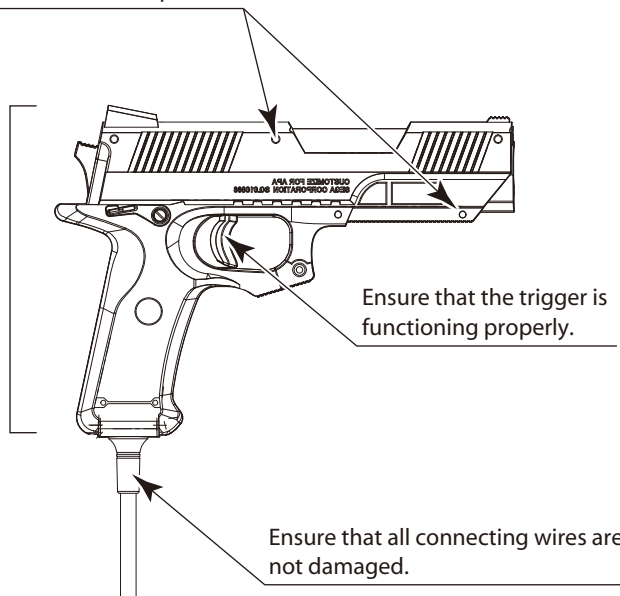

STOP IMPORTANT

- Players directly hold the controller with their bare hands so it is recommended that wet towels (paper towels) be provided.
- Placing the LCD monitor near halogen lamps or other types of light fixtures which emit strong light may cause a malfunction. Make sure to install the monitor at a reasonable distance from such sources of light.

3-2 DURING OPERATION (PAYING ATTENTION TO CUSTOMERS)

To avoid injury and trouble, be sure to pay attention to the behavior of visitors and players.

WARNING

- For safety reasons, do not allow any of the following people to play the game.
 - Those who need assistance such as the use of apparatus when walking.
 - Those who have high blood pressure or a heart problem.
 - Those who have experienced muscle convulsion or loss of consciousness when playing video games, etc.
 - Those who have neck or spinal cord problems.
 - Those who are intoxicated or under the influence of drugs.
 - Pregnant women.
 - Those who are not in good health.
 - Those who do not follow the attendant's instructions.
 - Those who cannot grasp the Control Unit securely because of immobility in fingers, hands or arms.
 - Persons who disregard the product's warning displays.
- Even players who have never been adversely affected by light stimulus might experience dizziness or headache depending on their physical condition when playing the game. Small children are especially likely to experience these symptoms. Caution guardians of small children to keep watch on their children during play.
- Instruct those who feel sick during play to have a medical examination.
- To avoid injury from falls and electric shocks due to spilled drinks, instruct the player not to place heavy items or drinks on the product.
- To avoid electric shocks and short circuits, do not allow customers to put hands and fingers or extraneous matter in the openings of the product or small openings in or around the doors.
- To avoid falls and resulting injury, immediately stop the customer from leaning against or climbing on the product, etc.
- To avoid electric shock and short circuit, do not allow customers to unplug the power plug without a justifiable reason.

CAUTION

- Immediately stop such violent acts as hitting and kicking the product. Such violent acts can cause parts damage or cause the cabinet to fall over, resulting in injury.
- Instruct players to hold the gun securely while playing. If the gun is dropped, it could cause injury to the player.
- Items such as large finger rings can cause injury to the fingers while playing. Instruct players to remove all accessories that could cause an accident before playing.
- Instruct players that a single gun is never to be held by two or more people during play. Otherwise there could be dangerous contact or a collision.

4 PART DESCRIPTIONS

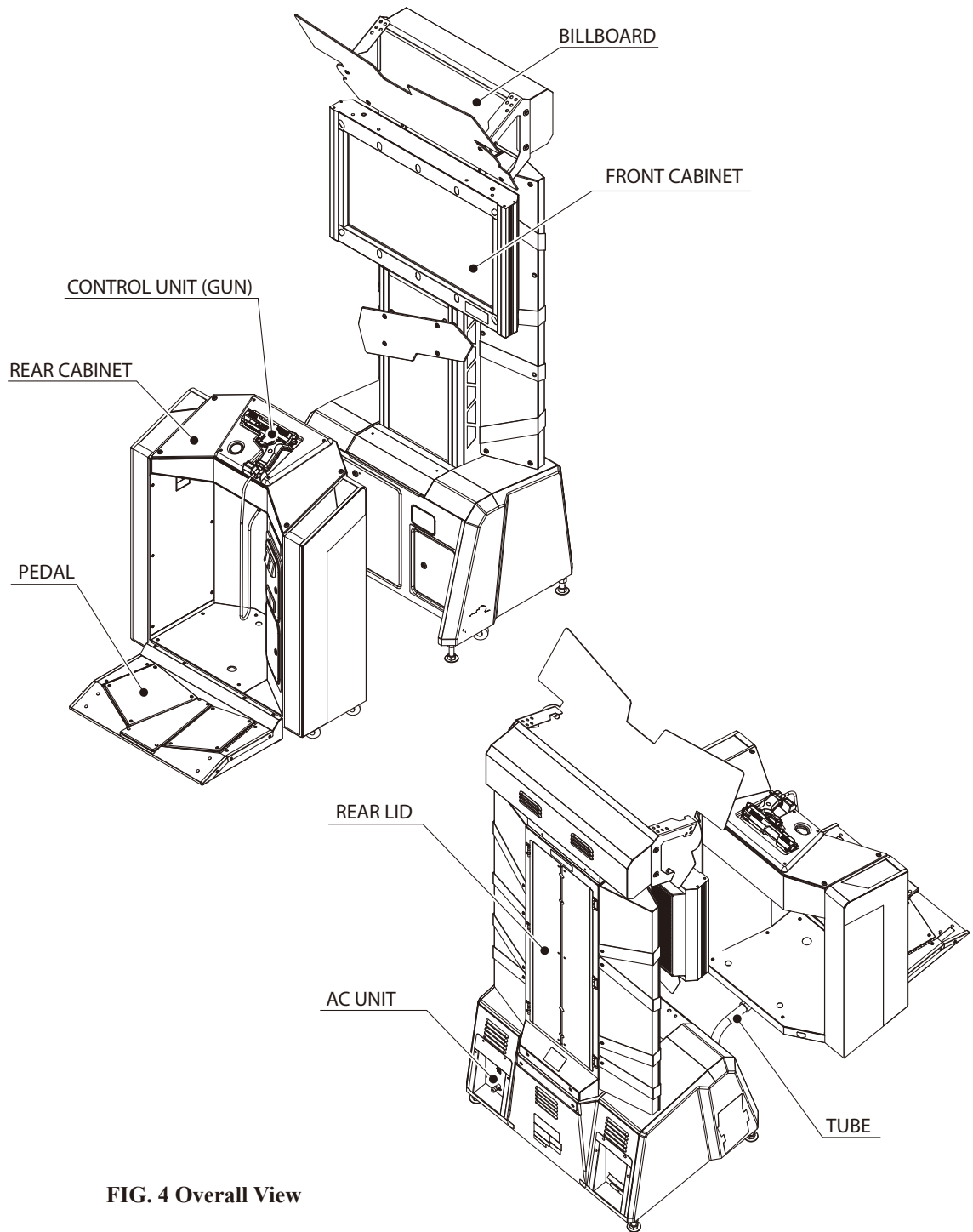

FIG. 4 Overall View

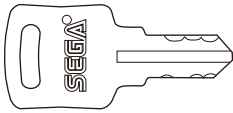
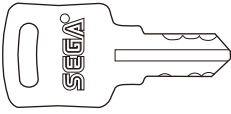
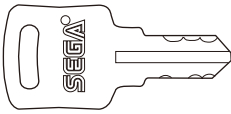

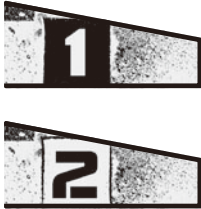
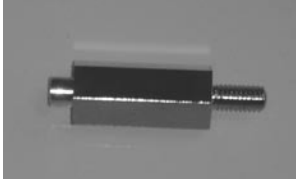
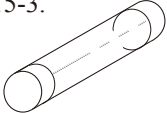
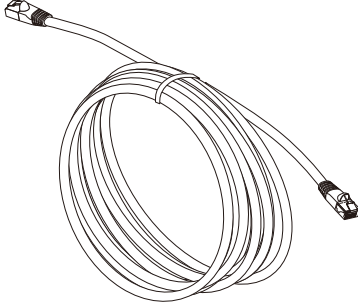
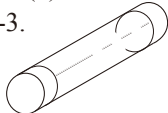
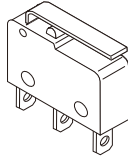

TABLE 4 Dimensions and Weights for Major Parts

ITEMS	Width x Depth x Height	Weight
BILLBOARD	865.5 mm (34.1 in) x 465 mm (18.3 in) x 455 mm (17.9 in)	12 kg (26.5 lb)
FRONT CABINET	820 mm (32.3 in) x 616 mm (24.3 in) x 1,732 mm (68.2 in)	116 kg (255.7 lb)
REAR CABINET	800 mm (31.5 in) x 370 mm (14.6 in) x 967 mm (38.1 in)	52 kg (114.6 lb)
PEDAL	622.5 mm (24.5 in) x 385.2 mm (15.2 in) x 86 mm (3.4 in)	11 kg (24.3 lb)
UPON COMPLETION (recommended)	865.5 mm (34.1 in) x 1664 mm (65.5 in) x 2176 mm (85.7 in)	191 kg (421.1 lb)

5 ACCESSORIES

Confirm that the accessories listed in the table below are present when setting up the product. Accessories marked “Spare” in the note column are consumable items but included as spares.

TABLE 5a ACCESSORIES

<p>DESCRIPTION: OWNER’S MANUAL Part No. (Qty.): 420-7031-01 (1) Note: This manual Figures: Parts not labeled with part numbers are as yet unregistered or cannot be registered. Be sure to handle all parts with care, as some parts are not available for purchase separately.</p>		<p>KEY MASTER 220-5793-2-A001 (2) For opening/closing the doors</p> 
<p>KEY (2) For the front cabinet’s cashbox door Located inside the service door of the front cabinet at time of shipment</p> 	<p>KEY (2) For the rear cabinet’s cashbox door Located inside the service door of the rear cabinet at time of shipment</p> 	<p>LINDBERGH RED SERVICE MANUAL 420-7032-01 (1) Explanation of built-in game board</p>
<p>FRONT DESIGN PLATE 1P, 2P APA-0001 (1) APA-0002 (1) For installation, see chapter 6 [9].</p> 	<p>STICKER 1P2P APA-0004 (1) For installation, see chapter 6 [5].</p> 	<p>PLATE LEG APA-0003 (4) For Front Design Plate installation, see chapter 6 [9].</p> 
<p>FUSE 250 V, 200 mA 514-5143-200 (1) Spare, see 15-3.</p> 	<p>NETWORK (LAN) CABLE 600-7269-0500 (1) For network play, see chapter 6 [5].</p> 	<p>FASTENER, WASHER FAS-290045 (4) 280-6686-01 (4) For Front Design Plate installation, see chapter 6 [9].</p>
<p>FUSE 250 V, 2 A 514-5143-2000 (1) Spare, see 15-3.</p> 	<p>MICROSWITCH 509-5080 (1) Spare, see chapter 10.</p> 	<p>HEAT SHRINKABLE TUBING (SUMITUBE F D 20MM) 310-5029-D20 (2) Spare, see chapter 10.</p> 

The parts listed in Table 5b are packaged separately, but they must always be attached when using the product. They are attached while assembling and installing the product.

TABLE 5b

DVD KIT (1)

KEY CHIP (1)

DVD-ROM (1)

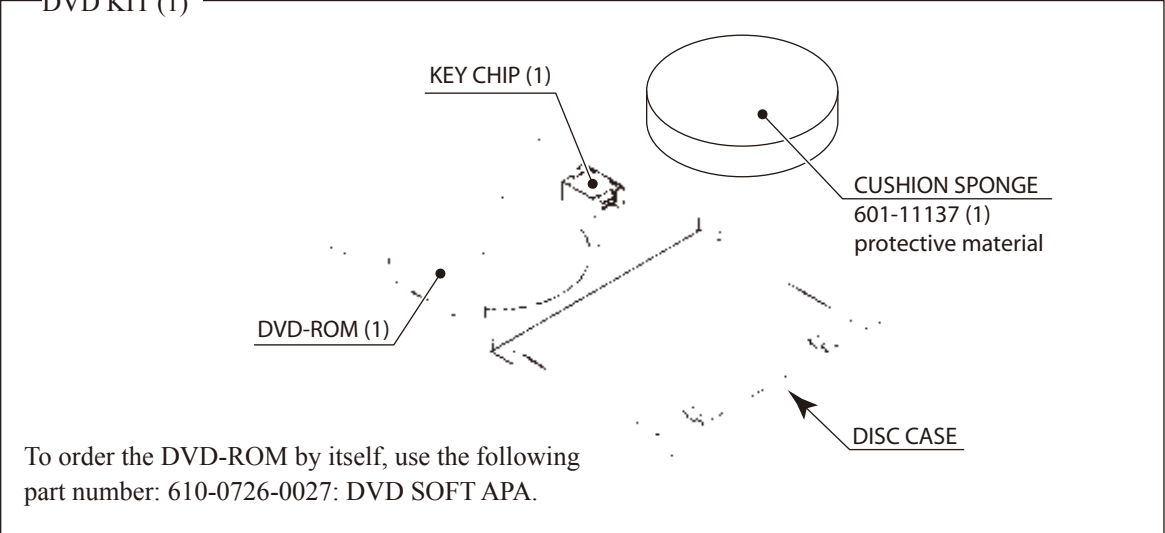

CUSHION SPONGE
601-11137 (1)
protective material

DISC CASE

To order the DVD-ROM by itself, use the following part number: 610-0726-0027: DVD SOFT APA.

POWER CABLE
 600-6729-01 (1) <Taiwan>
 600-6619-02 (1) <Singapore, Malaysia>
 600-6618-01 (1) <Others>
 For installation, see 6-4.

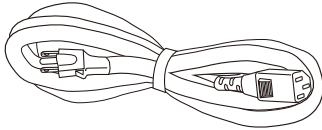

STICKER 845-0002D-02
 443-50002D-02 (1)
 Board number sticker, see chapter 6 [6].

845-0002D-02

DVD WIRE FOR LINDBERGH RED (2 m)
 605-0094-01 (1)
 For software installation, see chapter 6 [8].

NOTE: Use the (2 m) wire included with this product, and not the (1 m) wire included with the DVD DRIVE kit.

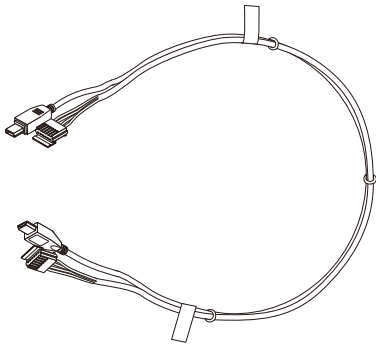

TABLE 5c XKT-1515-01: DVD DRIVE KIT FOR LBG ENG

SERVICE MANUAL
420-6923-01 (1)

DVD WIRE
605-0094 (1)
For software installation.

NOTE: Do not use with this product.

DVD DRIVE
610-0719-01-91 (1)
For software installation, see chapter 6 [8].

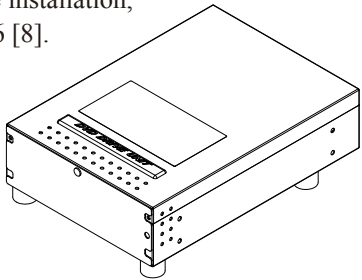

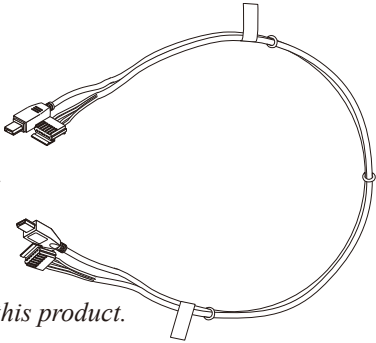

6 ASSEMBLY AND INSTALLATION

WARNING

- This work should be carried out by site maintenance personnel or other qualified professionals. Work performed by non-technical personnel can cause a severe accident such as electric shock. Failing to comply with this instruction can cause a severe accident such as electric shock to the player during operation.
- Perform assembly work by following the procedure herein stated. Failure to comply with the instructions can cause electric shock.
- Perform assembling as per this manual. Since this is a complex machine, incorrect assembling can cause an electric shock, machine damage and/or improper functioning as per specified performance.
- When assembling, more than one person is required. Depending on the assembly work, there are some cases in which working by one person alone can cause personal injury or parts damage.
- Ensure that connectors are properly connected. Improper connections can cause electric shock.
- Be careful not to damage the wires. Damaged wires may cause electric shock or short circuit or present a risk of fire.
- Do not carelessly push on the monitor. This could cause it to fall over.
- Provide sufficient space so that assembling can be performed. Performing work in places with narrow space or low ceiling may cause an accident and assembly work to be difficult.
- To perform work safely and avoid serious accident such as the cabinet falling down, do not perform work in places where step-like grade differences, a ditch, or slope exist.
- Do not use connectors other than those connected to and used by the game board at the time of shipment. Do not connect wires to unused connectors. This could cause the generation of heat or smoke, or a burnout.

CAUTION

- Wear appropriate work clothing so that work can be performed safely. Use gloves and safety shoes to prevent accidents or injuries.
- When installing a wire protection cover over a floor, use a material shaped so that no one passing by will stumble over it. Using a material that could be stumbled over might lead to an accidental fall.
- Be careful in handling plastic parts. Be sure not to tighten screws or nuts too tightly. If such parts are exposed to excessive loads or impact, they might become damaged, resulting in fragments or cracks that could cause accidental injury.

Installation and assembly of this product should take place in the following sequence.

- 1** Installation of Billboard
- 2** Connection of Front Cabinet, Rear Cabinet, and Tube
- 3** Fixation to Installation Site
- 4** Installation of Pedal
- 5** Preparation of Two Units for Competitive Play (1P: left side, 2P: right side)
- 6** Preparation for Software Installation
- 7** Connection of Power and Ground
- 8** Engagement of Power Supply and Software Installation
- 9** Installation of Front Design Plate
- 10** Engagement of Power Supply after Installing Software
- 11** Assembling Check

Use the following tools for assembly work.

- Philips screwdrivers (for M4,M6,M8)

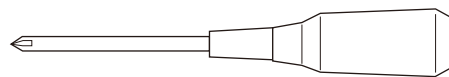

- Sockets for hexagon bolts and nuts (for M8)

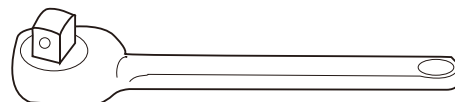

- Socket wrench



- 24 mm spanner

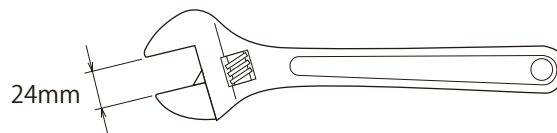

- MASTER KEYS (Accessory)

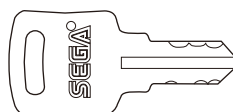

- ALLEN WRENCH (2.5 mm)

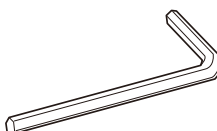

1 INSTALLATION OF BILLBOARD

- 1** Attach the billboard plate to the billboard box with four screws.

HEXAGON SOCKET SCREW (4)
M4 x 6, special washer used

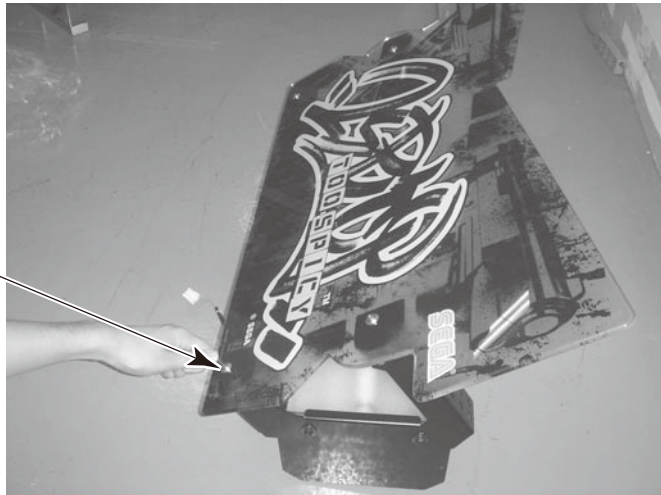

FIG. 6-1a

- 2** Two people lift up the billboard, and place it on the top of the front cabinet.

BILLBOARD

FRONT CABINET



FIG. 6-1b



FIG. 6-1c

- 3** Slide the billboard forward, pushing it into the gap.

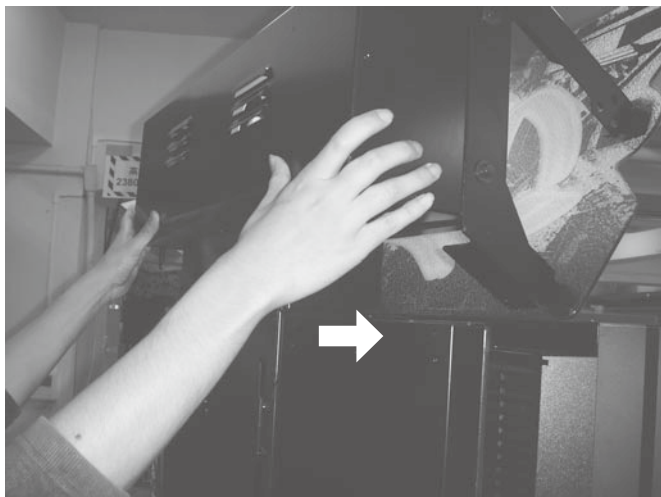

FIG. 6-1d

4 Secure with two screws.

TRUSS SCREW (2), black
M4 x 8

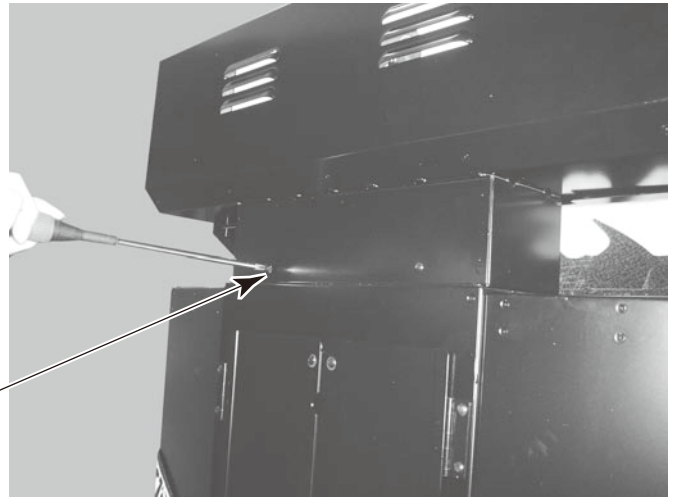

FIG. 6-1e

5 Remove the rear lid's six screws, open it, and connect the connector.

TRUSS SCREW (6), black
M4 x 8

REAR LID

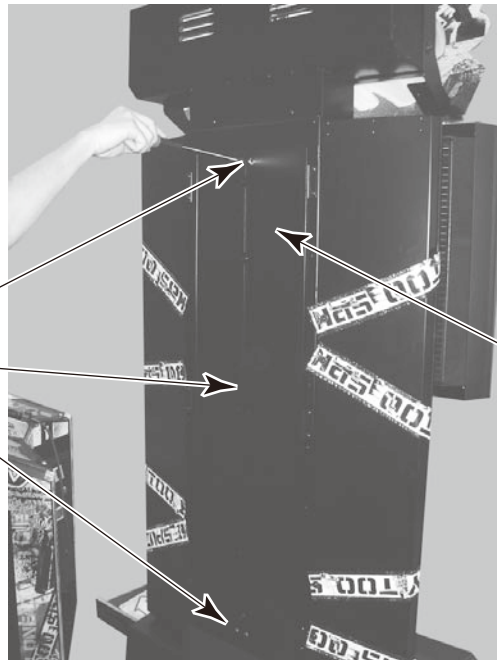

FIG. 6-1f

CONNECTOR (1)
VL 3P (white)

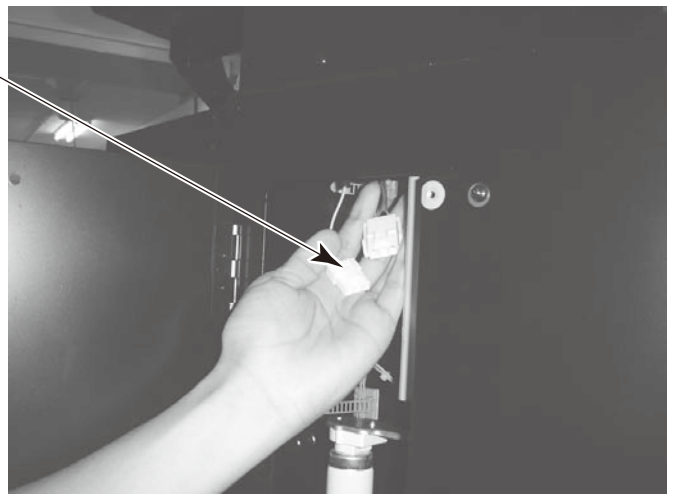

FIG. 6-1g

2 CONNECTION OF FRONT CABINET, REAR CABINET, AND TUBE

- 1** Open the front door using the master key.

MASTER KEY

FRONT DOOR

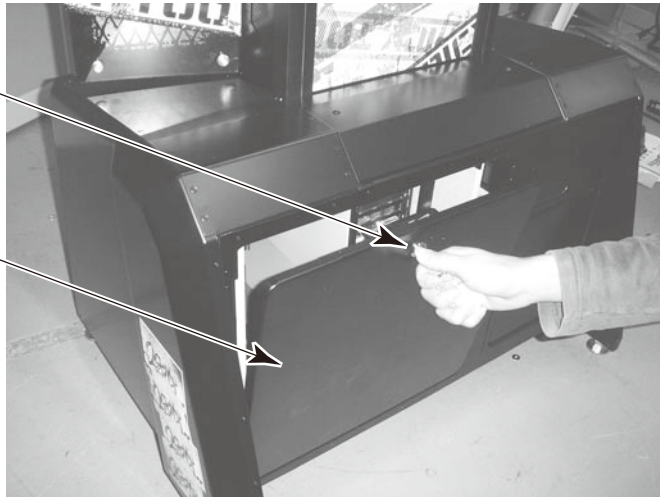

FIG. 6-2a

- 2** Remove the nut and washer of the tube before proceeding.

NUT

WASHER

TUBE
APA-0100

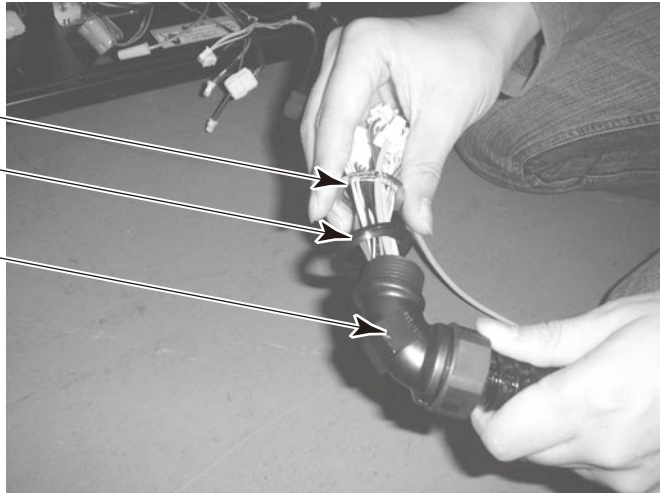

FIG. 6-2b

- 3** Run the tube wiring from the bottom side of the circular hole on the base of the front cabinet. After passing the washer through the wiring from the upper side, secure by tightening the nut.



FIG. 6-2c

4 Connect the seven connectors.

CONNECTOR (7)

VL 1P (white), YL 4P (white), YL 6P (white),
SM 2P (white), SM 3P (white), SM 4P (white),
SM 6P (white)

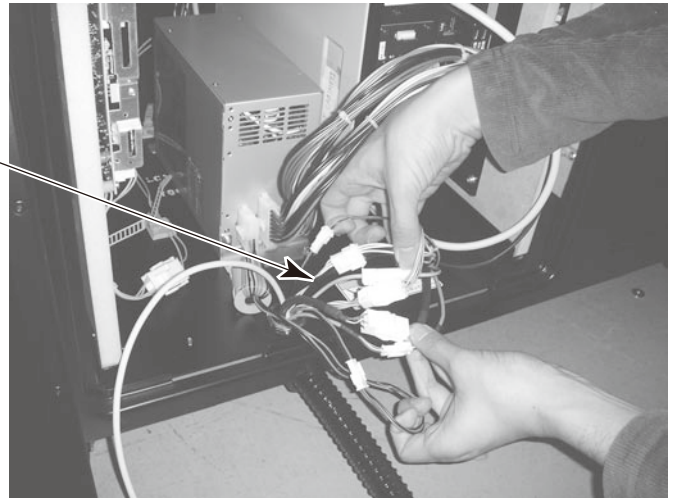

FIG. 6-2d

5 Connect the JVS cable, and close the front door.

JVS CABLE

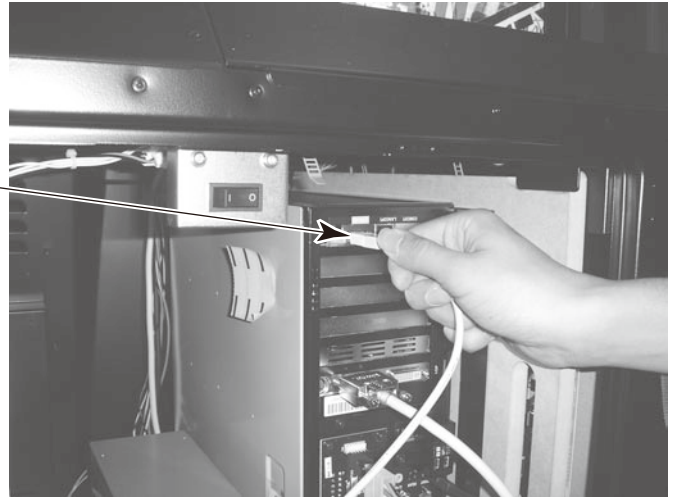

FIG. 6-2e

6 Remove the rear cabinet's foot lid after removing its six truss screws.

FOOT LID

TRUSS SCREW (6), black
M4 x 8

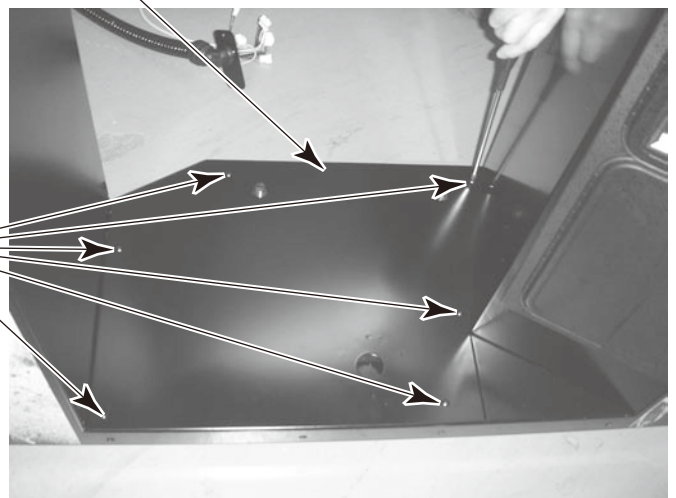

FIG. 6-2f

7 Run the tube wiring from the hole on the lower part of the rear cabinet. Fasten the sheet metal parts of the tube to the cabinet with two screws.

SCREW (2)
M4 x 12, w/flat & spring washers

TUBE
APA-0100

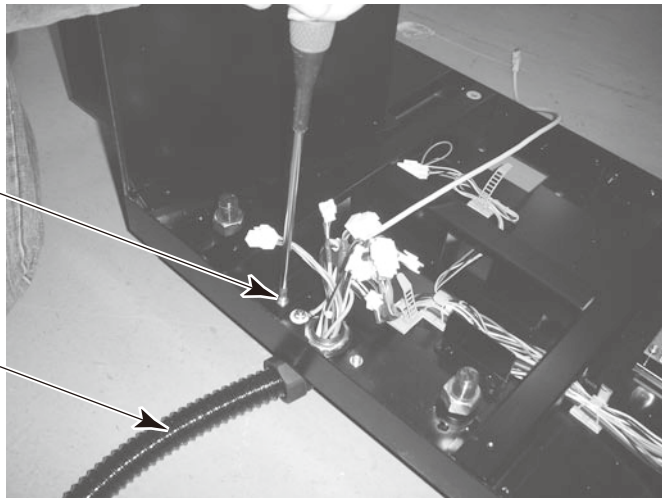

FIG. 6-2g

8 Connect the six connectors.

CONNECTOR (6)
YL 4P (white), YL 6P (white), SM 2P (white),
SM 3P (white), SM 4P (white), SM 6P (white)

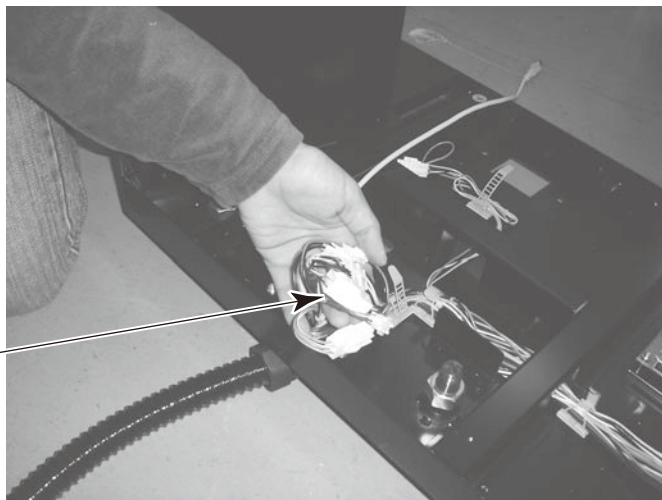

FIG. 6-2h

9 Connect the JVS cable as depicted, and attach the foot lid. When the above assembly work is complete, move the unit to the installation location.

JVS CABLE

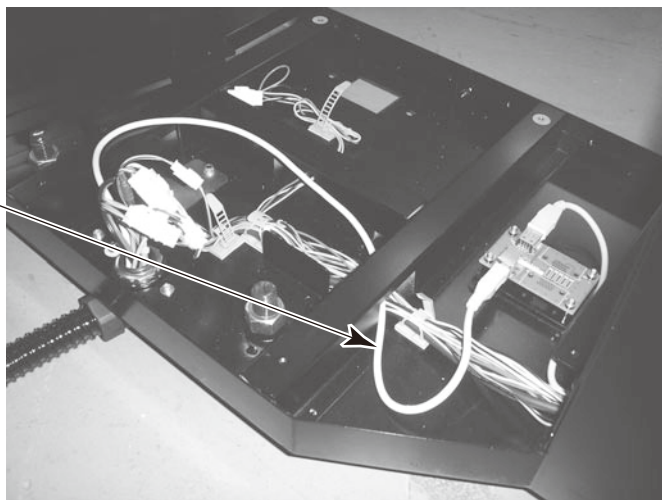

FIG. 6-2i

3 FIXATION TO INSTALLATION SITE

⚠ WARNING

Make sure that all the adjusters contact the floor. Otherwise the cabinet could move, causing an accident.

STOP IMPORTANT

The pedal unit should only be attached after moving the product to its installation site.

This product has eight casters (four on front cabinet, four on rear cabinet) and six adjusters (four on front cabinet and two on rear cabinet).

After determining the installation location, have the adjusters contact the floor directly, and adjust them so the machine will remain in a level position keeping a space of about 5 mm between the floor and the casters.

- 1 Move the product to the installation site. Move the main cabinet with two or more people, and the rear cabinet with one or more people.

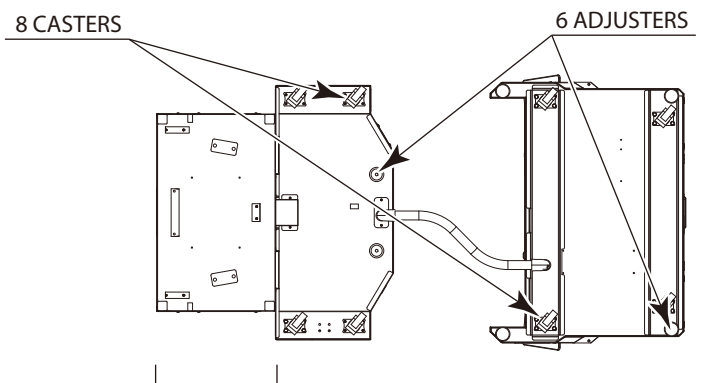

The pedal unit is installed after moving.

FIG. 6-3a Bottom View

- 2 Place the front cabinet's adjusters in contact the floor. Use a wrench to set adjuster heights so that the unit will stay level.
- 3 After setting, turn adjuster nuts upwards to tighten them and secure adjuster heights.

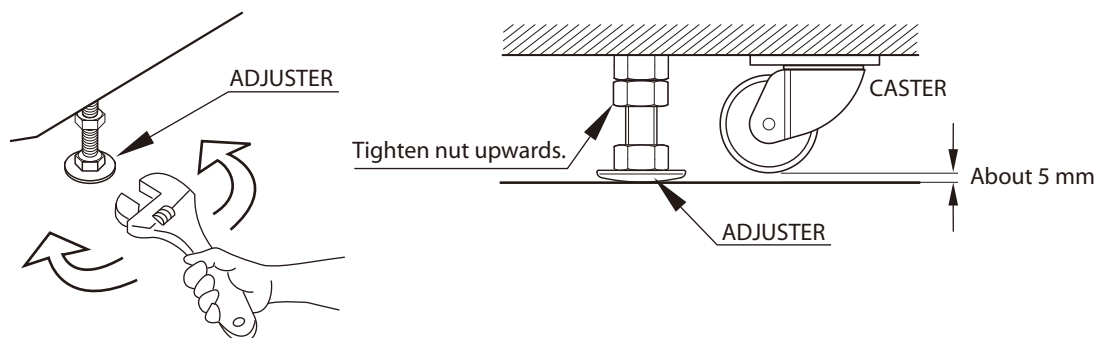

FIG. 6-3b Illustration of Adjuster Setting

- 4** The rear cabinet's adjusters are inside of the rear cabinet. Remove the rear lid, and adjust them using the same method as described for the front cabinet.

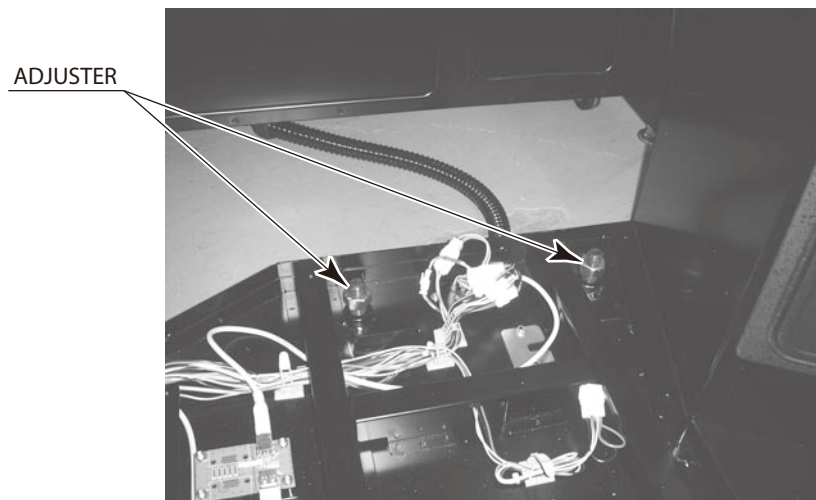

FIG. 6-3c

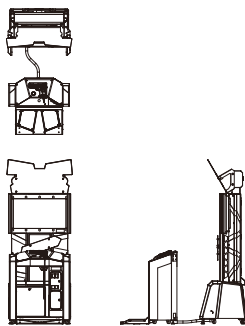

FIG. 6-3d Three Surface Views

Views are reduced to 1/100. Use them for reference in installation site layout.

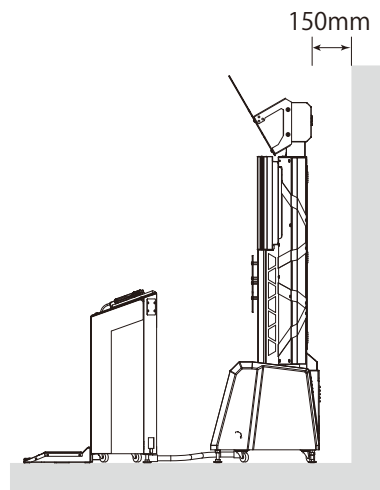

FIG. 6-3e Ventilation Space

Provide ventilation space for the ventilation opening.

4 INSTALLATION OF PEDAL

- 1 Remove the foot lid, and attach the wire cover rear to the base of the rear cabinet.

SCREW (2)
M4 x 12, w/flat & spring washers

WIRE COVER REAR

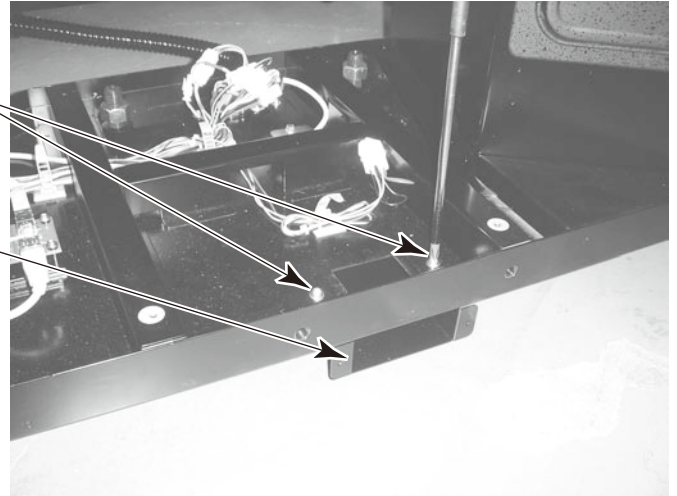

FIG. 6-4a

- 2 Remove the pedal base's pedal cover by removing the four truss screws.

TRUSS SCREW (4), chrome
M4 x 8

PEDAL COVER

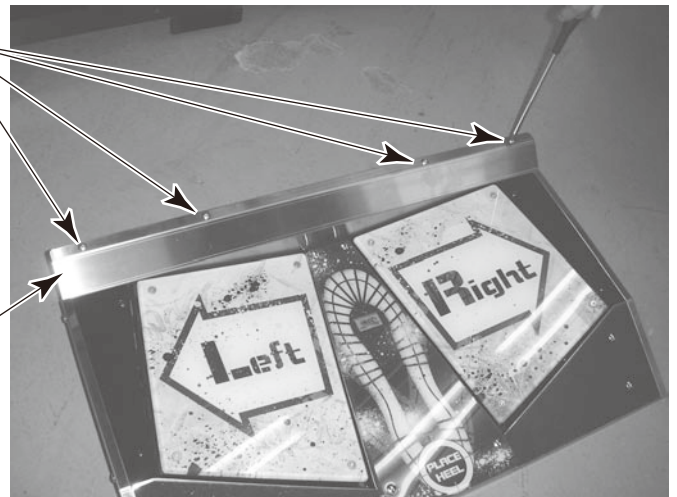

FIG. 6-4b

- 3 Connect the foot pedals to the rear cabinet, and secure them with four hexagon bolts.

HEXAGON BOLT (4)
M8 x 20, w/spring washer,
flat washer used

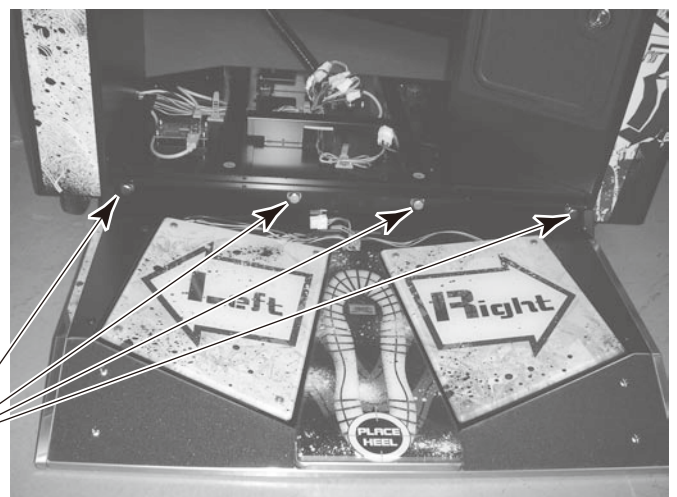

FIG. 6-4c

4 Secure the wire cover rear with two screws.

SCREW (2)
M4 x 12, w/flat & spring washers



FIG. 6-4d

5 Connect the connector.

CONNECTOR (1)
YL 6P (white)

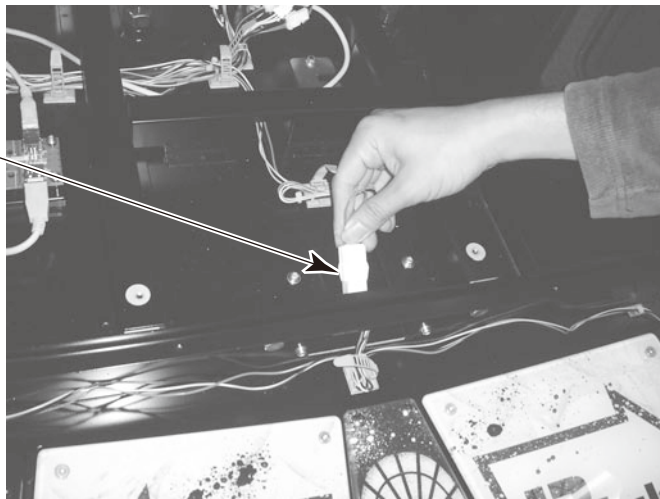

FIG. 6-4e

6 Use four truss screws to secure the foot lid and pedal cover in their original positions.

TRUSS SCREW (4), chrome
M4 x 8

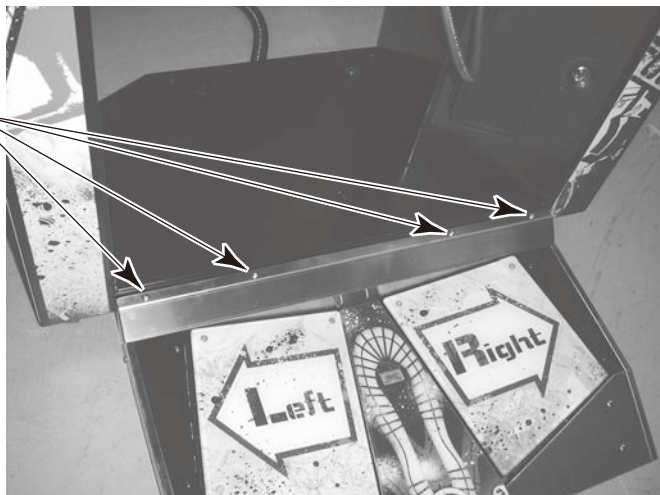

FIG. 6-4f

5 PREPARATION OF TWO UNITS FOR COMPETITIVE PLAY (1P: LEFT SIDE, 2P: RIGHT SIDE)

When not using two machines for competitive play, the procedure below is not necessary.

LAN Cable Connection

- 1 Run the included LAN cable from the back of the front cabinet.

LAN CABLE (5 m)
600-7269-0500



FIG. 6-5a

- 2 Open the front door with the master key. Connect the LAN cable, which has been drawn out from the back of the front cabinet, to the connector tagged "LAN" in the middle of the game board. Perform the same procedure on the 2P side.



FIG. 6-5b

- 3 For installation of two units to be used for competitive play, check the connection of the interference prevention wire while referring to Chapter 6, [10], and refer to Chapter 9 "Network Assignments".

Front Design Plate Replacement

Referring to chapter 6, [9], replace the front design plate 1P with a front design plate 2P.

FRONT DESIGN PLATE 2P



FIG. 6-5c

Sticker 2P Attachment

As shown in the picture, attach the accessory sticker 2P over the sticker 1P.

NOTE: The sticker 1P is not used at this time.

STICKER 2P



FIG. 6-5d

6 PREPARATION FOR SOFTWARE INSTALLATION

⚠ WARNING

- When connecting the DVD wire connector, check the orientation carefully and connect securely. The connector must be connected in the proper direction. If it is connected in the wrong direction or indiscriminately at an incline so that a load is applied, the connector or its terminal pins could break, causing a short circuit or fire.
- Be careful not to damage the DVD wire by getting it caught between objects, etc. Doing so may cause a short circuit or fire.
- Connect the DVD DRIVE to the LINDBERGH RED before connecting the power. Adhere strictly to the proper sequence in performing work. Failing to do so may cause electrical shock or short circuit.

Prepare the DVD DRIVE kit (sold separately) and the DVD wire (2 m) included with this product's DVD kit. In preparation for software installation, connect the LINDBERGH RED in the front cabinet to the DVD DRIVE with DVD wire.

- 1 Run the included DVD wire from the back of the front cabinet.

DVD WIRE
605-0094-01

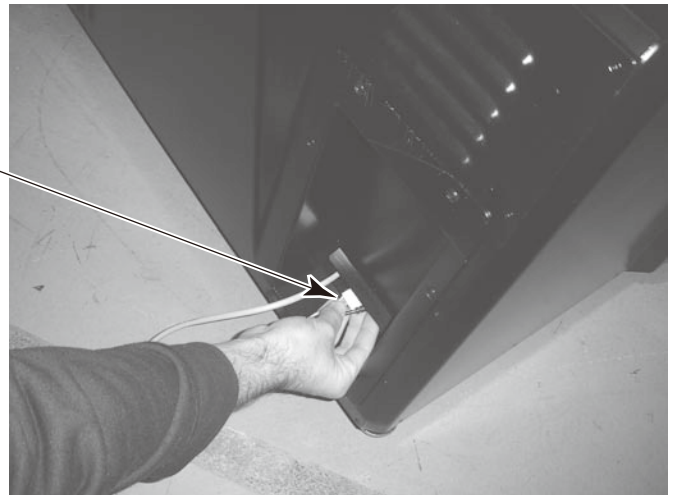

FIG. 6-6a

- 2 Connect the DVD wire to the game board's USB port. The wire can be connected to any of the four ports.



FIG. 6-6b

-
- 3** Insert the key chip and attach the accessory Board No. sticker.

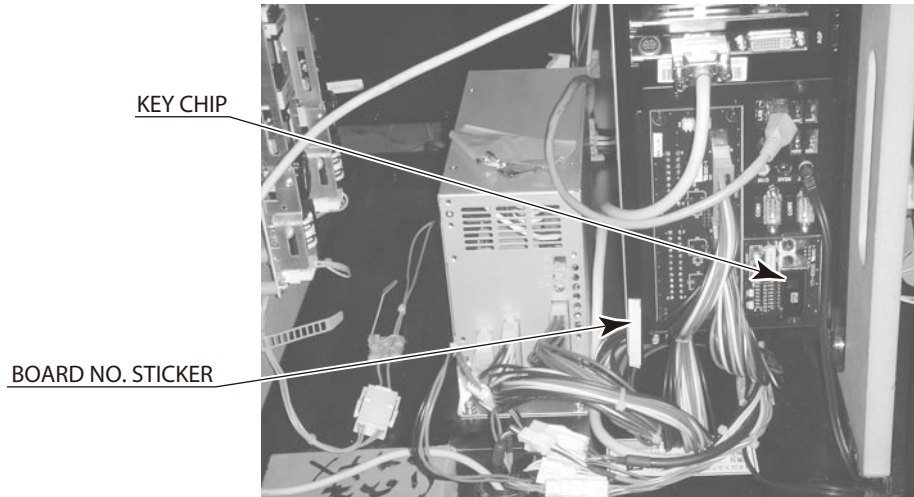

FIG. 6-6c

-
- 4** Connect the two connectors on the end of the DVD wire tagged "DVD" to the side of the DVD drive.

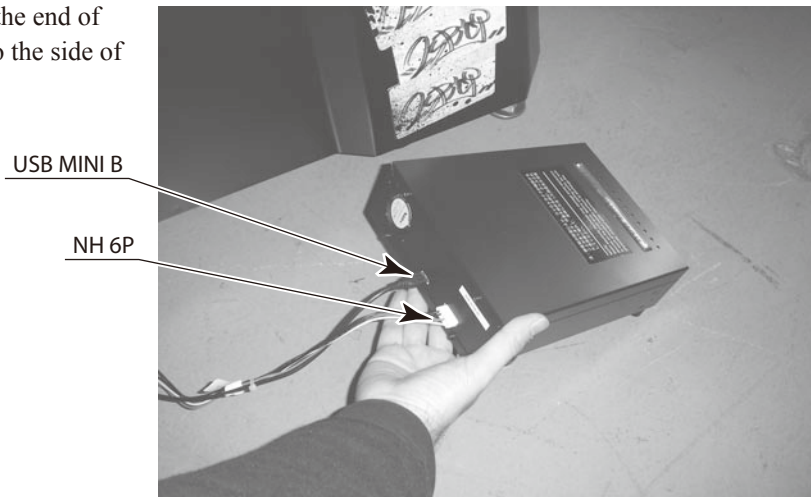

FIG. 6-6d

-
- 5** Verify that the sub power switch inside the front cabinet is turned on. Close and lock the front door.

7 CONNECTION OF POWER AND GROUND

⚠ WARNING

- Use the power supply equipped with an earth leakage breaker. Use of power supply without such a breaker could result in fire if there is a current leakage.
- Have available a securely grounded indoor ground terminal. Without proper grounding, customers could be electrocuted and product operations might not always be stable.
- Do not expose the power cord or ground wire. If these are exposed, customers could stumble over them, for instance, and easily damage them. Additionally, if these lines are damaged, there could be a risk of electrical shock or short circuit. Set these lines at locations where they will not interfere with customer traffic, or attach covers to them.
- After laying out the power cord on the floor, be sure to always protect it. If the power cord is left exposed, it can easily be damaged, resulting in electrical shock.
- When using the product's AC unit ground terminal, use ground wire with a circular terminal as shown in the illustration, and establish ground securely. Avoid indiscriminant grounding operations such as use of wire with only its sheath peeled off.

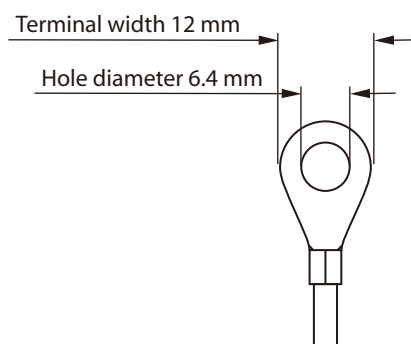

STOP IMPORTANT

If grounding has been established with the ground wire inside the power cord, do not perform grounding with the AC unit ground terminal. Conversely, if the AC unit ground terminal has been used for grounding, do not establish ground with the ground wire in the power cord. Otherwise there could be faulty or erroneous operations.

The accessory power cord has a ground wire inside it.

Connect the power cord to the AC unit then insert the power cord plug into a “power outlet with ground terminal.” If there is no “power outlet with ground terminal,” be sure to establish ground by some other means; for example, by connecting the AC unit ground terminal to a ground wire with a ground mechanism prepared separately. If you use a conversion adapter sold on the market to supply power, connect the ground wire terminal of the adapter to a “securely grounded ground terminal.” <For Taiwan>

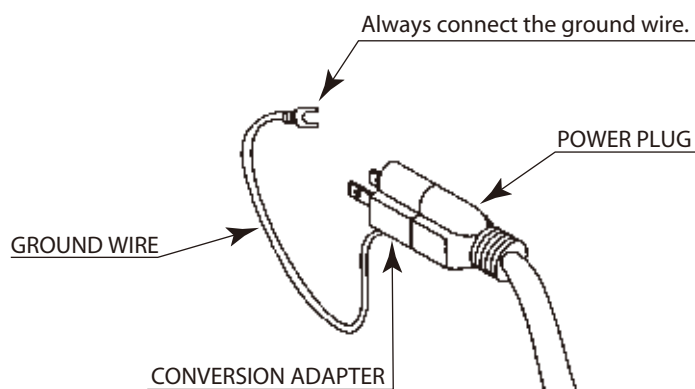

FIG. 6-7a

- 1** Confirm that the main switch is at OFF.

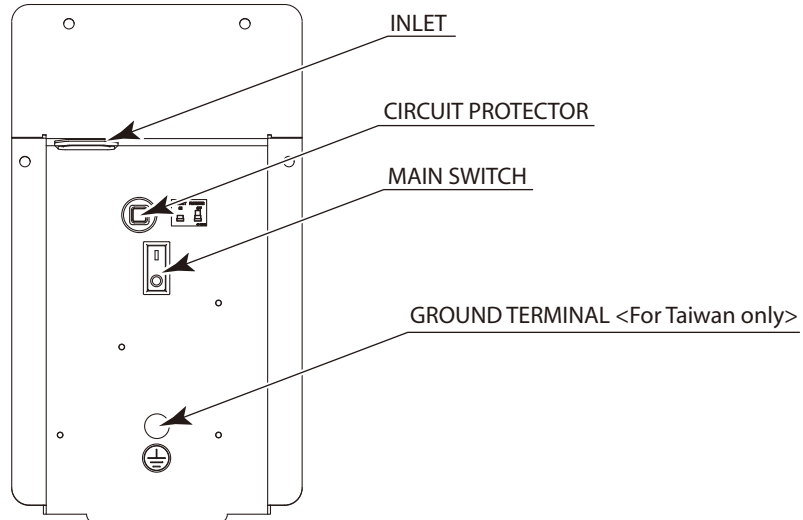
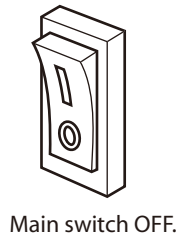

FIG. 6-7b AC Unit

- 2** Fully insert the power cord connector on the side opposite the power plug into the AC unit inlet.

- 3** Fully insert the power cord plug into the outlet.

- 4** When using a ground wire made available separately, connect one end of the wire to the AC unit ground terminal and the opposite end to an indoor ground terminal. The AC unit ground terminal is a bolt-and-nut combination. Remove the nut and pass the bolt through the ground terminal, then secure the nut to the bolt. <For Taiwan>

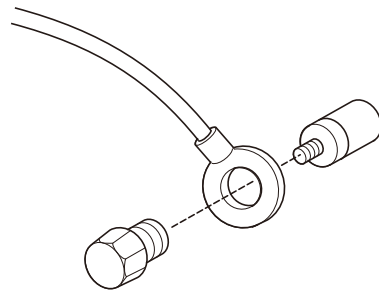

FIG. 6-7c

- 5** The power cord is laid out indoors. Protect the power cord by attaching wire cover to it. If ground will be established with a ground wire made available separately, lay out the ground wire indoors and have it protected. <For Taiwan>

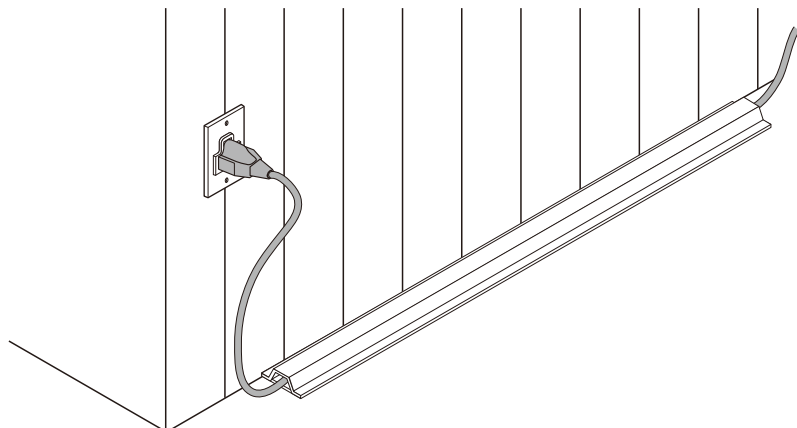

FIG. 6-7d

8 ENGAGEMENT OF POWER SUPPLY AND SOFTWARE INSTALLATION

WARNING

- Be careful not to damage the DVD wire by getting it caught between objects, etc. Doing so may cause a short circuit or fire.
- The following explanation assumes that the product has been assembled properly as explained above. If there is an error or if the product operates in a manner other than as indicated below, cut off the power supply immediately. Failure to do so may result in a fire or electrical shock.
- If you look directly at the laser beam in the DVD DRIVE, you could suffer vision impairment. Do not look inside the DVD DRIVE.

STOP IMPORTANT

- The software is not installed on the game board (LINDBERGH RED) when the power supply is engaged, so the “Error 22” message is not a malfunction. However, if there is another error display, or if there is no video output at all, there might have been an error in product assembly, wiring connections might be faulty, or the LINDBERGH RED might not be functioning properly.
- After the power supply is engaged, wait for “Error 22” message to be displayed. If the product is indiscriminately operated in any way beforehand, there could be unexpected problems or malfunctions, as well as damage to parts.
- Once “Error 22” is displayed, set the DVD-ROM in the DVD DRIVE and re-engage the power supply. Installation takes place.
- After the power supply is engaged, the DVD DRIVE tray will not come out for about 30 seconds even if you press the switch. This is due to DVD DRIVE initialization.
- The DVD DRIVE tray can come out or return only while the power supply is engaged. The tray cannot be opened or closed while the power is off.
- Even after the software has been installed, store the DVD software kit, DVD DRIVE and DVD wire in a secure location.
- If for any reason installation cannot be completed, an error is displayed. Refer to the service manual and take corrective action.

Prepare the DVD DRIVE kit (sold separately). (See Table 5c.)

Use the DVD wire (2 m) included with this product, and not the wire included with the DVD DRIVE kit.

1 Turn the main switch of the AC unit to ON and engage the power supply.

2 The LINDBERGH RED Startup Screen appears. Wait for at least one minute. The error state is established. Check to be sure it is “Error 22.” If it is “Error 22,” proceed to the next operation. If it is not “Error 22,” refer to the LINDBERGH RED Service Manual and take corrective action.

- 3** Take out 1 urea (resin-head) screw and remove the DVD DRIVE case lid.

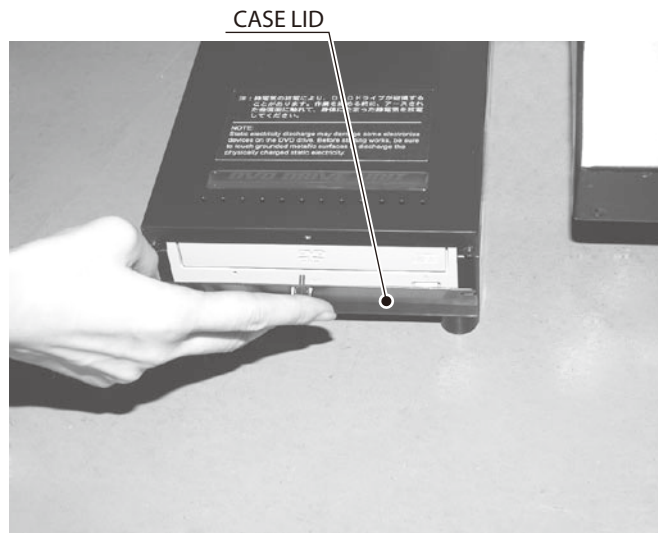

FIG. 6-8a

- 4** Press the DVD DRIVE switch and the DVD DRIVE tray will come out. Set the DVD from the DVD kit into the tray. Always have the labeled side facing upward.

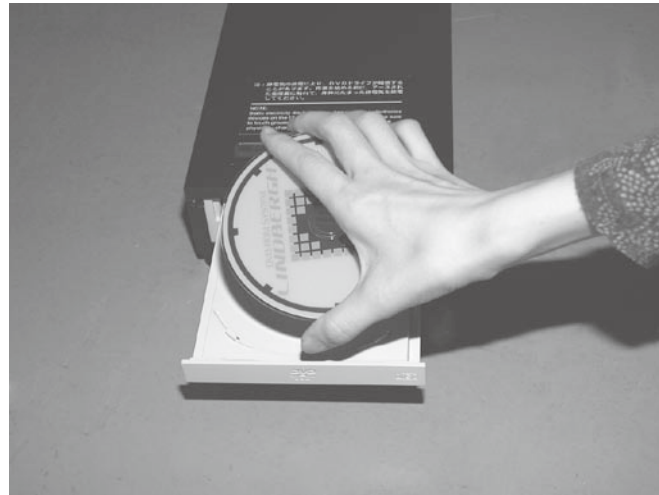

FIG. 6-8b

- 5** Press the DVD DRIVE switch. The tray goes back into the drive.
- 6** Turn the main switch to OFF once, wait for at least one minute, then turn the switch back to ON.
- 7** Software is installed automatically from the DVD to the LINDBERGH RED. In some cases, it may take about 5 minutes to install software to the LINDBERGH RED.
- 8** Upon completion of installation, initialization takes place automatically.
- 9** Initialization is completed when the Attract Mode Screen appears.
- 10** Press the DVD DRIVE switch so that the tray comes out. Remove the DVD.
- 11** Press the DVD DRIVE switch so that the tray goes back into the unit. If the power is cut off, the tray will not move.
- 12** Set the main switch to OFF.

13 Remove the DVD wire from the DVD DRIVE.

14 Attach the DVD DRIVE case lid and fasten it with 1 urea screw.

15 Unlock and remove the front door.

16 Remove the DVD wire from the LINDBERGH RED and withdraw it from the back side of the front cabinet.

17 Attach and lock the front door.

18 Store the DVD DRIVE, DVD wire and DVD DRIVE kit in a location free of dust and cigarette smoke.

9 INSTALLATION OF FRONT DESIGN PLATE

1 Attach four plate legs to the front cabinet.

PLATE LEG



FIG. 6-9a

2 Attach the front design plate 1P using included four screws.

HEXAGON SOCKET SCREW (4)
M4 x 6, special washer used

FRONT DESIGN PLATE 1P



FIG. 6-9b

10 ENGAGEMENT OF POWER SUPPLY AFTER INSTALLING SOFTWARE

Turn the AC unit's main switch to ON to turn on the power. When the power is turned on, the fluorescent lights inside of the billboard and on the front cabinet's left and right will illuminate. Shortly afterwards, the System Startup Screen will be displayed, which will then change to the Customer Waiting Screen (Attract Mode).

The time required for Attract Mode to begin will vary from seconds to minutes. The time required will not be the same each startup.

Sound will come from the woofer in the center of the front cabinet and the rear cabinet's left and right speakers as soon as Attract Mode begins. The control panel and START Button will illuminate or flash based on directions from the game.

Credit count and ranking data will be retained even if this product's power is turned off. However, fractional coin counts (the count of coins inserted that were not sufficient for a credit) and bonus adder count data will not be saved.

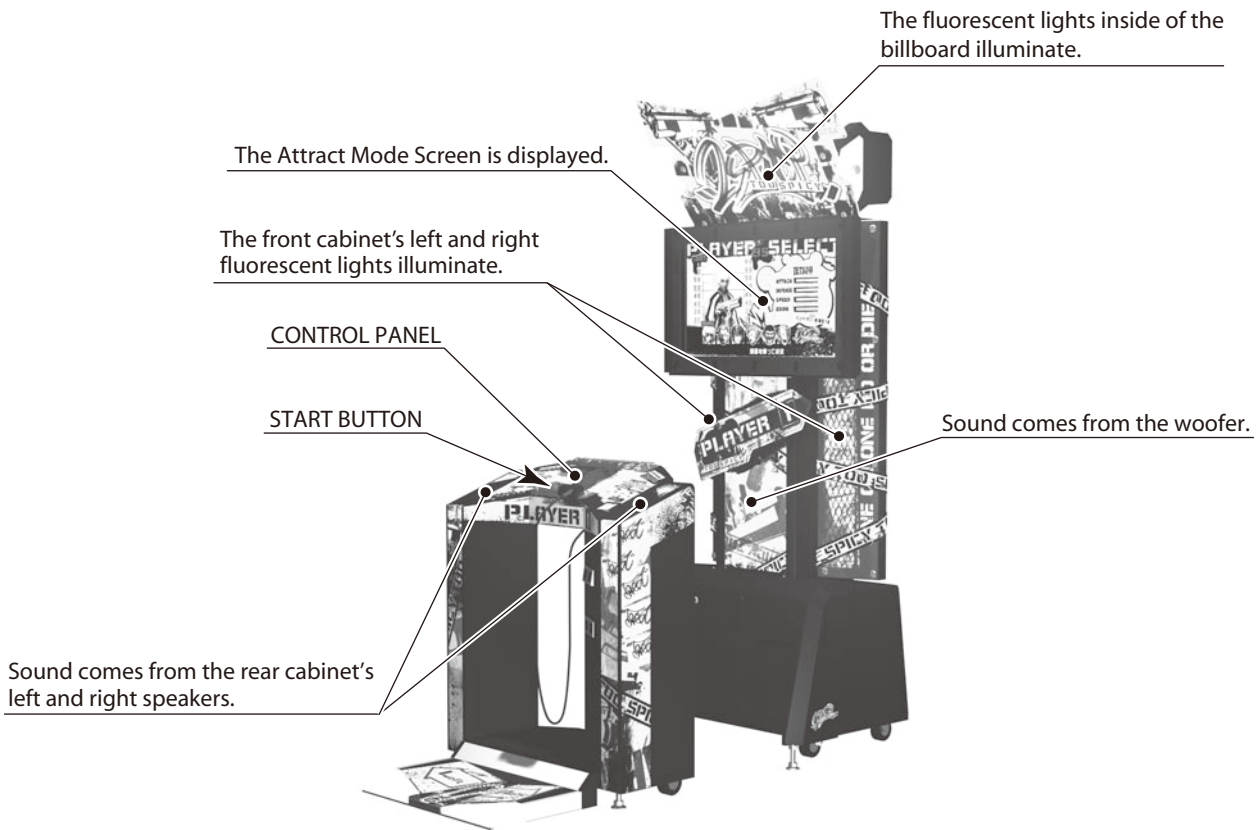

FIG. 6-10

11 ASSEMBLING CHECK

Using Test Mode, verify points such as the proper assembly of the machine. Also verify normal operation of the LINDBERGH RED, boards which have been connected, and the product's various input and output devices. In Test Mode, conduct the tests described below.

(1) MONITOR TEST

When MONITOR TEST is chosen from System Test Menu Screen, a screen to test the LCD will be displayed. Though the LCD is pre-adjusted at the time of shipment from the factory, view the test screen to determine whether or not adjustment is necessary. If so, refer to Chapter 11 and adjust the LCD.

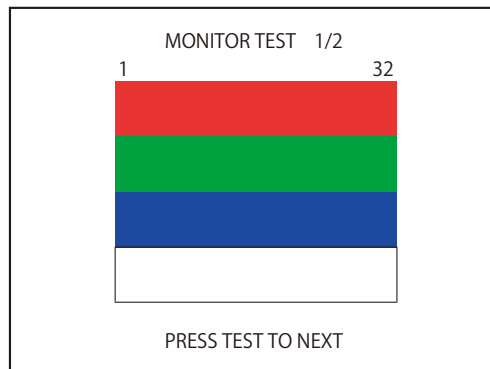

FIG. 6-11a

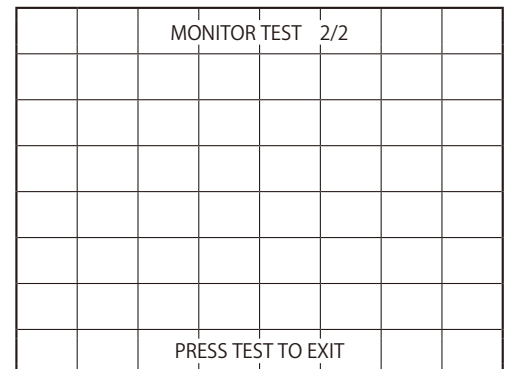

FIG. 6-11b

(2) SPEAKER TEST

When SPEAKER TEST is chosen from System Test Menu Screen, a screen to test each of the speakers will be displayed.

The RIGHT SPEAKER and the LEFT SPEAKER are the only speakers which can be checked by just changing their respective settings to ON and OFF. The WOOFER SPEAKER will only output sound when sound from the RIGHT/LEFT SPEAKER is outputted at the same time. No sound will be outputted by only changing its own setting to ON.

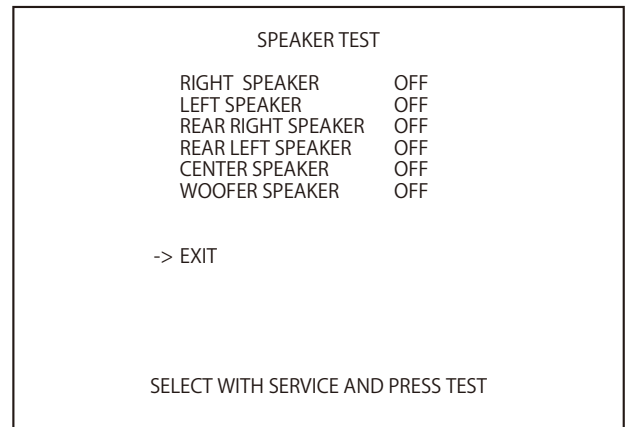

FIG. 6-11c

(3) INPUT TEST

When INPUT TEST is chosen from Game Test Menu Screen, a screen to test the game's switches will be displayed.

Flip each switch. If the display that appears to the right of the switch changes to "ON", the switch and its wiring are normal.

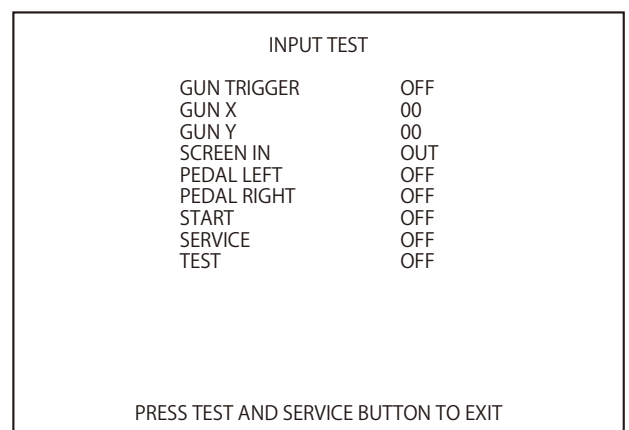

FIG. 6-11d

(4) OUTPUT TEST

When OUTPUT TEST is chosen from Game Test Menu Screen, a screen to test lamps and their wiring connections will be displayed. Verify that the lamps illuminate correctly.

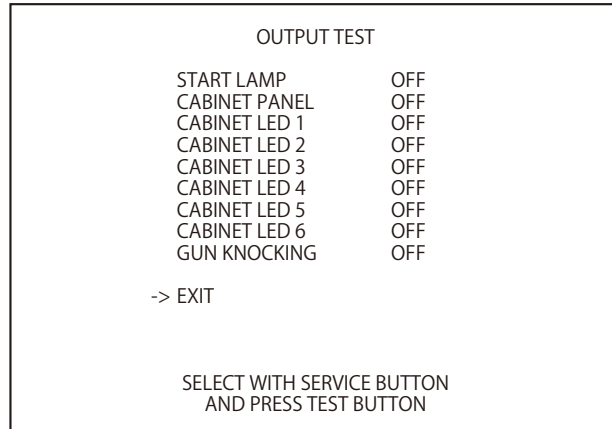

FIG. 6-11e

(5) GUN ADJUSTMENT

When GUN ADJUSTMENT is chosen from Game Test Menu Screen, a screen for adjusting the gun crosshair will be displayed.

Before operating the product, always play the game to verify that there are no irregularities during play and that the crosshair does not require adjustment. Though the crosshair is adjusted at the factory, adjustment may be required in some situations because the product is disassembled for shipment.

NOTE: Strong lighting located near the LCD monitor, other machines in the surrounding area, and other objects may have an effect on the gun adjustment.

The above inspections should be conducted regularly as part of a monthly inspection. However, GUN ADJUSTMENT should be conducted once per week.

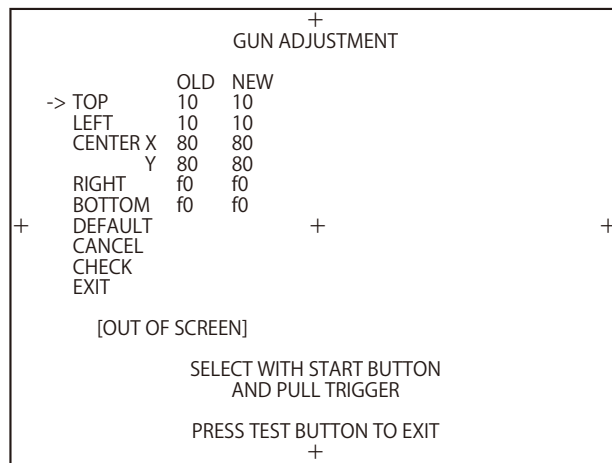

FIG. 6-11f

(6) NETWORK ASSIGNMENTS

When NETWORK ASSIGNMENTS is chosen from Game Test Menu Screen, a communications settings screen will be displayed. To connect two machines for competitive play, both cabinets must be setup. Choose the communication method and CABINET ID as appropriate.

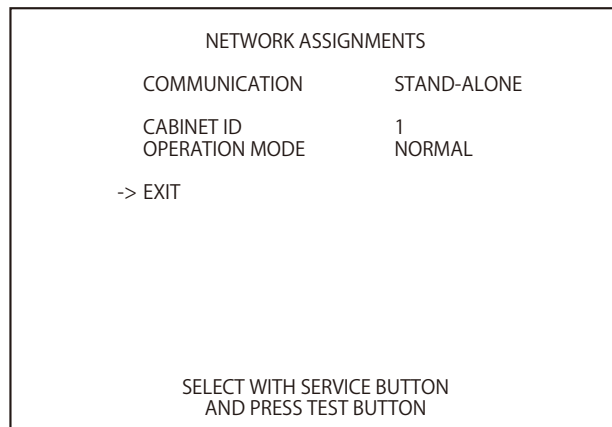

FIG. 6-11g

The Interference Prevention Wiring

⚠ WARNING

- This work should be performed by the site maintenance individual or other skilled professional. Work performed by non-technical personnel can cause malfunctioning.
- In order to prevent electric shock and short circuit hazards, be sure to turn power off before performing work.
- Be careful not to damage the wires. Damaged wires may cause electric shock or short circuit or present a fire risk.

When the game machines of a same or similar type are installed side by side, their sensors may interfere with each other. To reject the interference, follow the procedure below.

The following game machines employ a same or similar type of sensor. If interference happens to the sensors, operation of the games may be mutually disturbed.

- THE HOUSE OF THE DEAD 2, U/R type, DX type and Super DX type
- DEATH CRIMSON, U/R type and DX type
- THE LOST WORLD, U/R type, DX type and Super DX type
- BRAVE FIRE FIGHTERS
- SAMBA DE AMIGO
- CONFIDENTIAL MISSION, U/R type and DX type
- SHAKATTO TAMBOURINE
- LUPIN THE 3RD THE SHOOTING, U/R type and DX type
- THE MAZE OF THE KINGS, U/R type and DX type
- THE HOUSE OF THE DEAD 3, U/R type and DX type
- VIRTUA COP 3, U/R type and DX type
- GHOST SQUAD, U/R type and DX type
- THE HOUSE OF THE DEAD 4 DX type and SPECIAL type
- 2SPICY

- 1 Turn off the power.
- 2 Open the coin chute door. It's an interference prevention wire with "FREQ" tag.
- 3 When arranging two machines side by side and setting them for competitive play, or simply arranging two like game machines next to one another, the machines should be arranged such that one machine has its interference prevention wire connected, and the other does not. Be sure to keep the removed interference prevention wire.

INTERFERENCE PREVENTION WIRING
APA-60038

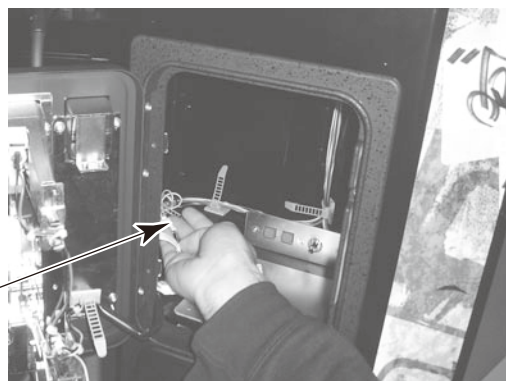

FIG. 6-11h

7 PRECAUTIONS WHEN MOVING THE MACHINE

⚠ WARNING

- Always disconnect the power cable before moving the product. If it is moved with the power cable connected, the cable could be damaged, causing fire or electric shock.
- To move the unit over the floor, pull in the adjusters and have the casters contact the floor. While moving the unit, be careful that the casters do not roll over the power cord or the ground wire. If cord or wire is damaged, there could be electrical shocks and/or short circuits.
- To lift up the cabinet, hold it at the bottom. If you hold it anywhere else, the weight of the cabinet could cause damage to parts or attachments, resulting in injury.
- To install this product, the entrance must be at least 1.7 m (5.6 ft) in width and 2.2 m (7.2 ft) in height. If the entrance is too narrow, do not tilt the product carelessly. If all the product weight is put on the casters at one side only, there could be damages or deformations, causing serious accidents such as workers getting caught underneath.
- If the unit cannot be taken through the entrance, do not disassemble it indiscriminately. Do not disassemble the unit in any way other than as instructed in this manual. Indiscriminate disassembly could result in electrical shocks, short circuits, or accidents while working on or operating the unit, leading to injuries.

⚠ CAUTION

- Do not hold or press the plastic parts as indicated by the figure. Failure to observe this instruction may break the parts, and eventually the broken pieces may cause a personal injury.
- Remove the pedal unit. It is very difficult to move the product while the pedal unit is attached. Failure to remove it could cause an accident. Parts could also become damaged or deformed, and the floor surface could be damaged.

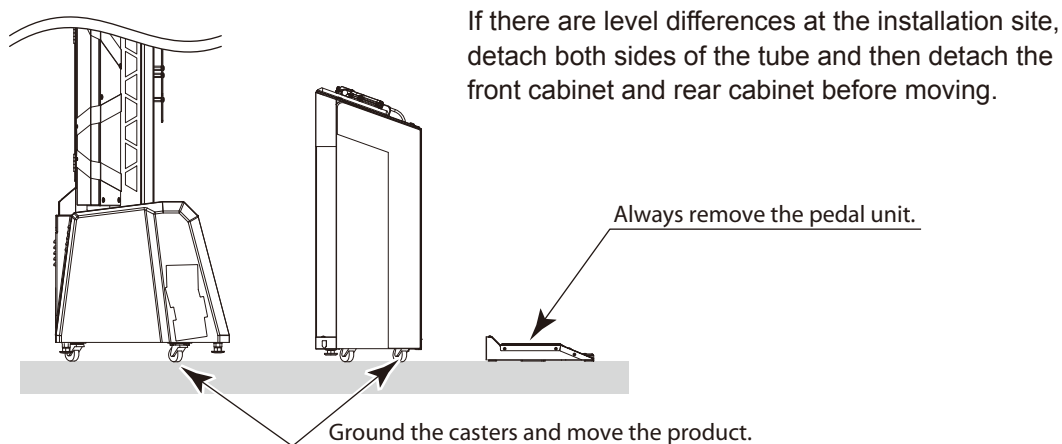
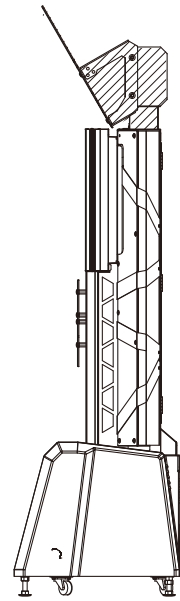
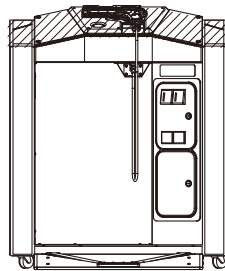
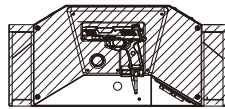
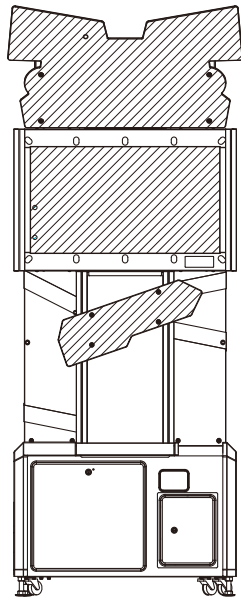

FIG. 7a

7 PRECAUTIONS WHEN MOVING THE MACHINE



Do not move or push the product holding the shaded areas.

FIG. 7b

8 GAME DESCRIPTION

The following explanations apply when the product is functioning satisfactorily. Should there be any operations different from the following contents, some sort of abnormality may have occurred. Immediately look into the cause of the fault and eliminate the cause thereof to ensure satisfactory operation.

When the cabinet is powered, a fluorescent lamp on the billboard and two fluorescent lamps (L and R) on the tower will always be illuminated.

The LCD screen will display demo videos and rankings.

Sound is output from the left and right speakers on the rear cabinet's control panel. There is also a woofer output in the center of the front cabinet.

Whether or not sound is output during Attract Mode can be chosen within Test Mode's settings.

The START Button on the control panel is an illuminated button. In Attract Mode, this button is not lit up.

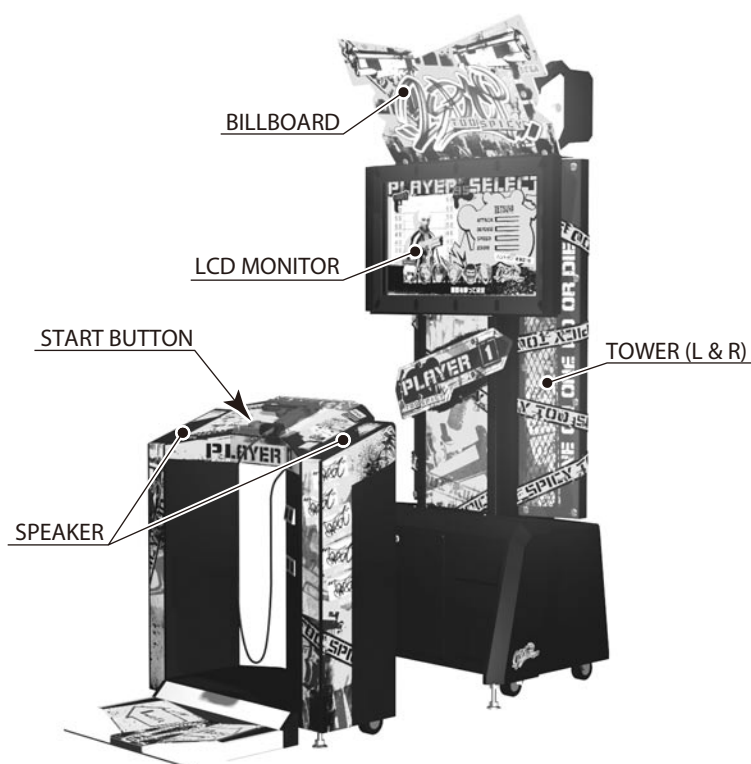

FIG. 8

(1) HOW TO PLAY

- 1 When a coin is inserted, the credit display on the bottom of the screen will increase in number.
When a sufficient number of coins to play either of the game's modes is inserted, the "INSERT COIN(S)" message on the bottom of the screen will disappear, and the display of the playable game mode will change to "XX Mode: PRESS START BUTTON". The START Button will then begin to blink.

Up to twenty four credits can be counted. If coins are inserted after twenty four credits have been counted, they will not be counted towards credits, and they will not be returned. However, they will be counted as inserted coins for the coin meter and for Test Mode data.



FIG. 8.1a



FIG. 8.1b

- 2 When the START Button is pressed, the tutorial will begin.
Follow the instructions that display on the screen to practice using the controls.
The tutorial can be skipped by pressing the START Button once again.
- 3 When the tutorial is over, the Game Mode Select Screen will be displayed.
Point the gun (control unit) towards the screen to highlight a mode, and pull the trigger to select.
Modes for which sufficient credits have not been entered cannot be selected.

Versus Mode:

One on one, player vs. player mode. When an opponent is not available, the game will be against a computer opponent.

Story Mode:

A mode for single players with numerous missions to clear. Each character has a different story.

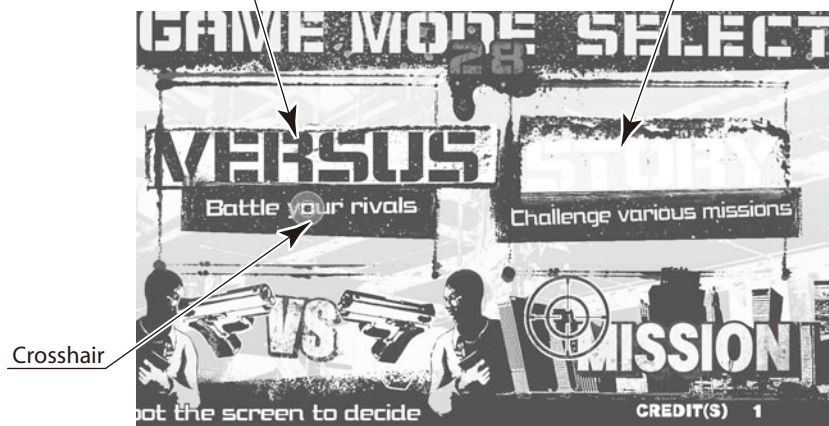

FIG. 8.1c

- 4 When a mode is selected, the Player Select Screen will be displayed.
Point the gun at the screen and highlight a player, and pull the trigger to select.
The game will begin after a player is selected.

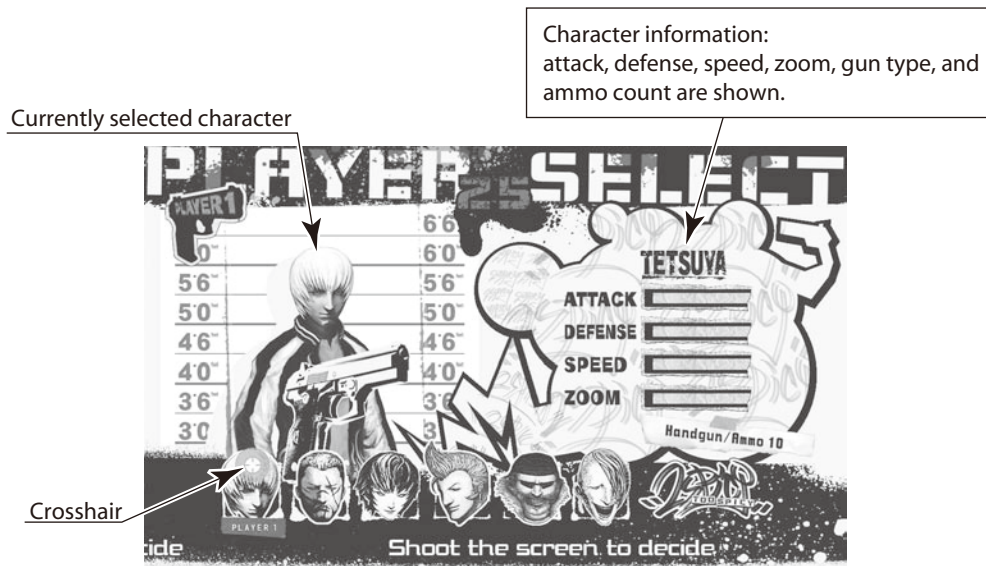

FIG. 8.1d

(2) GAME SCREEN

In the middle of the top of the screen, the remaining time is shown. On the left side of the time is the player's life and remaining shots, and on the right side is the enemy's life. On either side of the bottom of the screen, the possible movement directions are displayed.

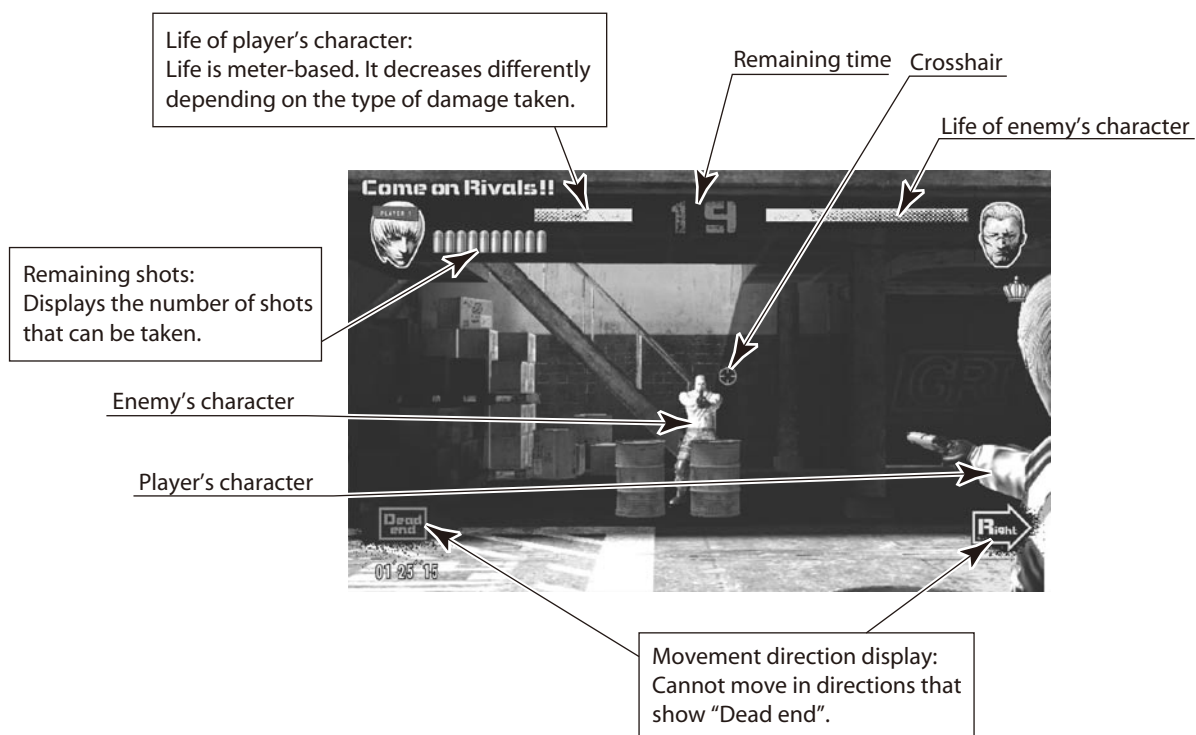
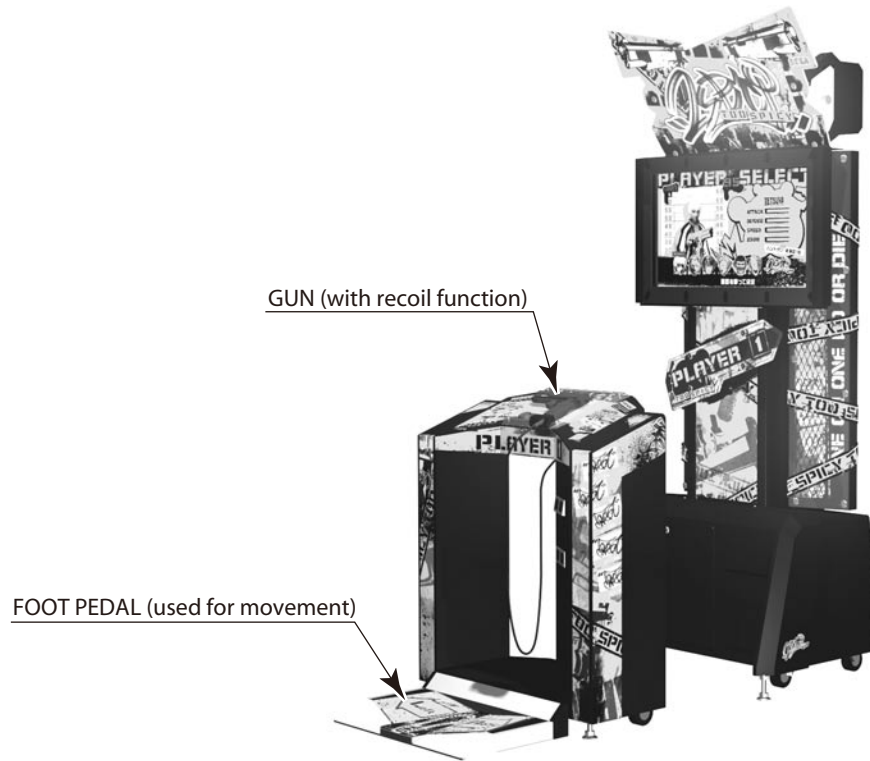

FIG. 8.2

(3) CONTROL INSTRUCTIONS**FIG. 8.3a**

When the gun is pointed at the screen, it can be fired.

When the gun is pointed away from the screen, players can hide behind cover such as oil drums and pillars. Taking cover will reduce the amount of damage taken from enemies.

Also, when the gun is pointed away from the screen, animation showing the character loading the gun will begin. This allows ammo to be replenished.

**FIG. 8.3b**

Players can move between cover items by stepping on the pedals.

While moving, players can point the gun at the screen to fire, or point the gun away from the screen to reduce damage taken from enemies and to replenish ammo.

Also, as long as one of the pedals is held down, players will continue to move without stopping until they proceed to the next item.

While moving, stepping on a pedal twice will enable a "Jump Shot" if the gun is pointed at the screen, or a "Dodge" if the gun is pointed away from the screen.

The camera will zoom in if the crosshair remains on the enemy or a cover item on the enemy's side for a specified amount of time.

While zoomed, attack power will increase, and hitting an enemy in the head will result in a "Head Shot" that deals a large amount of damage.

Some cover items can be destroyed by shooting them, and, if a character is near the item at such a time, they will take damage and be knocked down.

When knocked down, players can step on the pedals to get up quickly.



Player is in danger. Will also be displayed when an enemy is zooming in on the player.

FIG. 8.3c

Displayed while down. Players can get up quickly by stepping on the pedals.

(4) VERSUS MODE

This is a one on one competitive mode. There are eight stages.

When the game is started with just one cabinet, players will face a character controlled by the computer. (COM Battle)

When two cabinets are connected, if the other cabinet starts a game and Versus Mode is chosen, players can face one another. (Player Battle)

When the opponent's life reaches zero, the surviving player has won that round. The winner will be the player who wins the previously specified number of rounds.

If in a COM Battle, the winner will then advance to the next stage. If in a Player Battle, the winning player will move on to a COM Battle.



Number of rounds won

Elapsed game play time

FIG. 8.4a

For the loser, “CONTINUE?” will display.

By inserting the necessary amount of coins and pressing the START Button, the player can continue.

If enough credits already remain, the START Button can be pressed without inserting additional coins.

When in a COM Battle, the player will continue the game from the stage they couldn't get past. In a Player Battle, players will once again face off.



FIG. 8.4b

If the loser does not continue or a player clears all stages, the game will be over.

If the total time for clearing all stages is within the top ten in the rankings, the player can enter their name.

NOTE: Time during a Player Battle is excluded.



FIG. 8.4c

(5) STORY MODE

This mode allows players to enjoy a storyline while clearing a large number of missions. The story of each character is different.

When beginning Story Mode, players can choose to play a Practice Mission. The Practice Mission allows players to practice using controls that were not introduced during the tutorial. This Practice Mission can be skipped, even while underway, by pressing the START Button.



FIG. 8.5a

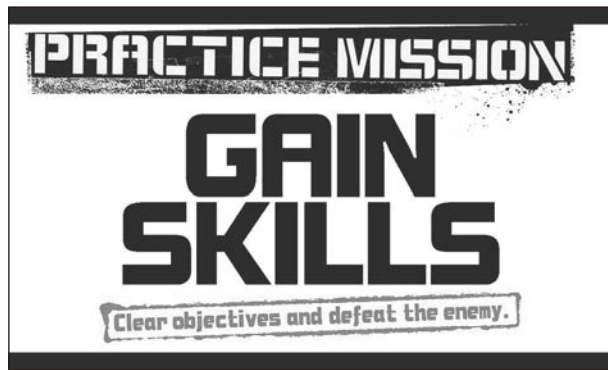

FIG. 8.5b

If the Practice Mission was completed or was fully or partially skipped, a “Story” will be displayed, and the game will continue in the order shown below.

- 1) Demo
- 2) Mission Title
- 3) Mission
- 4) Mission Clear Screen (Success / Failure)
- 5) If the mission is a failure, the game can be retried from step 2) of the same mission (excludes Bonus Missions).
- 6) If the mission is a success, the game proceeds to step 1) of the next mission.
- 7) Steps 1) - 6) repeat a number of times, as the player moves through the demo, Stage Results display, and on to the next stage.

Mission Points. If a mission cannot be cleared, one ☆ will be deducted. When “☆” reaches zero, the game is over. When a Bonus Mission is cleared, one ☆ will be gained (unless the player is already at the maximum number).



FIG. 8.5c

When a mission is cleared, the score displayed depends on the player's remaining energy, remaining time, skill attainment, and the number of attempts needed to clear that mission.



FIG. 8.5d

If a mission could not be cleared, a Mission Point will be deducted and the player retries the mission. When all Mission Points are depleted, "CONTINUE?" will display.

By inserting the necessary amount of coins and pressing the START Button, the player can continue. If enough credits already remain, the START Button can be pressed without inserting additional coins. When continuing, the player will retry the same mission.



FIG. 8.5e



FIG. 8.5f

If the player does not continue after all Mission Points are depleted, or the player clears all stages, the game will be over.

If the total score from clearing all of the stages is within the top three in the rankings for that selected character, players can enter their name.



FIG. 8.5g

(6) MATCHING

Versus Mode is normally started when both players are matched up together and then competitive play begins. It is also possible for players to be matched up if both are playing Story Mode, or one is playing Story Mode and the other Versus Mode.

Versus Mode vs. Versus Mode

The first player who wins the number of rounds specified in the Test Mode's MATCH COUNT setting will be the winner, and can continue the game.

The game will be over for the player who loses.

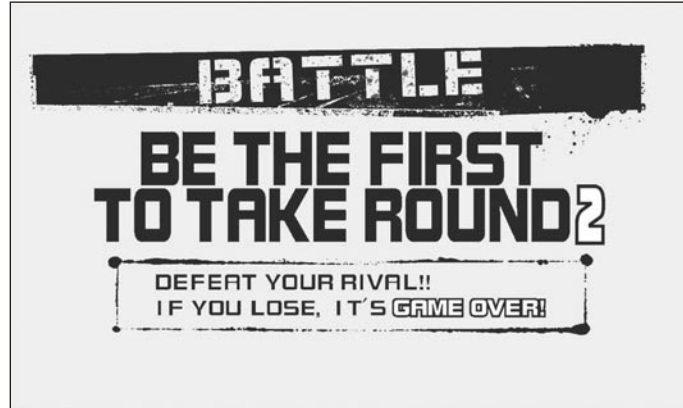

FIG. 8.6a

Story Mode vs. Story Mode

Story Mode vs. Versus Mode

- When Versus Mode was being played:
There will be one round of competition in the form of a sudden death trial battle.
The game will not be over for the player that loses.

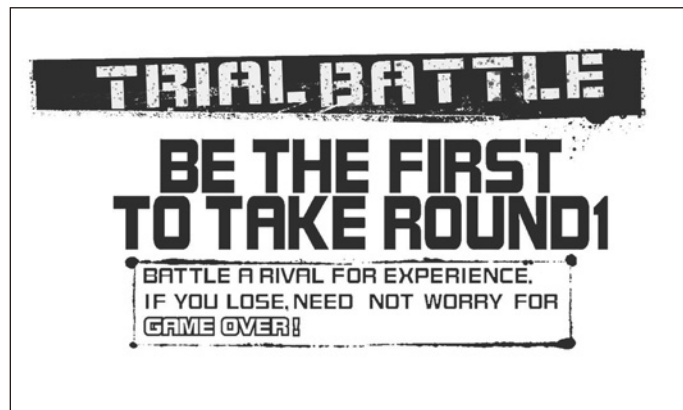

FIG. 8.6b

- When Story Mode was being played:
If a player has not already acquired the maximum number of Mission Points, they will receive a ☆ by winning. If a player already has the maximum number of Mission Points, there will be one round of competition in the form of a sudden death trial battle. The game will not be over for the player that loses.

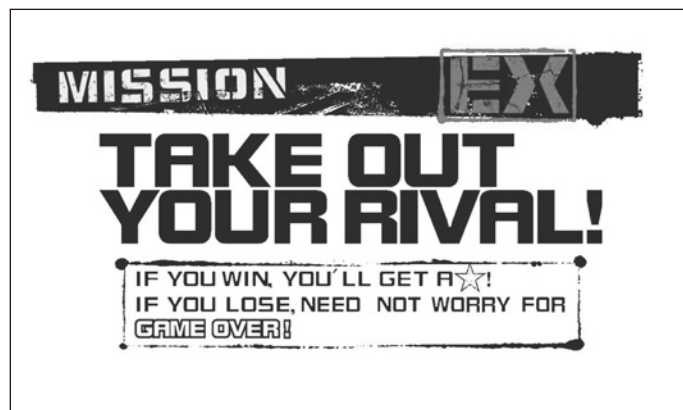

FIG. 8.6c

(7) CHARACTER LIST

All characters are androids created by a company called GRI.

To obtain information regarding an inheritance left behind by the “Boss”, they pursue the “Man in Black” a.k.a. “Shadow”.



FIG. 8.7a

• TETSUYA

[Handgun / Ammo 10]

Seeks to repay his debt to the Yakuza by obtaining the inheritance.

A standard, balanced character.

Does not become immobile for a short time after a Jump Shot.

Stumbles often when shot in the legs.



FIG. 8.7b

• ALEXANDER

[Gun w/Scope / Ammo 8]

A former Russian Army android used to handling weapons.

Currently hired by an organization seeking the inheritance.

Uses zoom very effectively.



FIG. 8.7c

• MING-HUA

[Dual Pistols / Ammo 20]

A female thief planning to use Shadow’s information to get lots of money from organizations throughout the world.

Two shots will be fired for a single pull of the trigger.

Has a powerful jump shot.



FIG. 8.7d

• CHARLIE

[Machine Gun / Ammo 20]

A special secret agent who wants to obtain the inheritance for the prosperity of his country.

Rapid fire is possible by holding down the trigger.

Moves quickly.



FIG. 8.7e

• LAURENCE

[Shotgun / Ammo 4]

An experimental GRI android.

Bears a grudge against Shadow, and seeks revenge for the death of his dog Washington.

Carries a highly destructive shotgun. Because of his heavysset physique, moves very slowly.



FIG. 8.7f

• SICKS

[Revolver / Ammo 6]

Self-proclaimed “gourmet killer”.

Got involved in assassinations thanks to Shadow.

Can disappear while moving, but if he stops or is hit, he will reappear.

(8) STAGE LIST

- **Warehouse Stage**

GRI's warehouse.

Destroy pillars to have them fall on enemies, or stop enemies from moving using steam from the valves.



FIG. 8.8a

- **Hong Kong Stage**

On the roof of a building in Hong Kong.

Destroy signs to have them fall on enemies, or stop enemies from moving using smoke from outdoor machinery.



FIG. 8.8b

- **Japan Stage**

A traditional Japanese restaurant.

Use the tables for cover during battle.



FIG. 8.8c

- **Smuggling Boat Stage**

On the deck of a container freighter.

Containers move around, so cover may be lost, exposing the player to fire.



FIG. 8.8d

- **Desert Stage**

At an isolated gas station in the desert.
Destroy gas pumps or cars to inflict secondary damage on enemies.



FIG. 8.8e

- **Subway Stage**

An abandoned subway station.
Destroy pillars to have them fall on enemies.
Trains sometimes pass through. This allows the player to move if they time things right.



FIG. 8.8f

- **Factory Stage**

GRI's factory.
Battle atop always moving conveyer belts.



FIG. 8.8g

- **Mansion Stage**

The private residence of the president of GRI.
Destroy statues to have them fall on enemies.



FIG. 8.8h

9 EXPLANATION OF TEST AND DATA DISPLAY

WARNING

Do not touch any parts that are not specified in these directions. Touching unspecified locations may lead to electric shock or cause short circuits.

CAUTION

Be careful that a finger or hand does not get caught when opening/closing the coin chute door.

STOP IMPORTANT

- When you enter the Test Mode, fractional coin and bonus adder data is erased.
- Adjust the sound to the optimum volume, taking into consideration the environmental requirements of the installation location.
- Removing the coin meter circuitry renders the game inoperable.

Perform tests and data checks periodically by manipulating the TEST Button and SERVICE Button in the cabinet. Follow the instructions in this chapter to conduct checks when the game machine is first installed, when money is being collected, or when the game machine does not operate properly.

Shown below are the tests and screens to be used for different problems.

This product uses a LINDBERGH RED game board and a DVD DRIVE. In the system, a different game can be played by putting a different DVD ROM in the DVD DRIVE.

For this reason, the product's Test Mode consists of two modes: a System Test Mode for systems in which coin settings, for instance, are made for products that use the same system, and a Game Test Mode for setting of difficulty level, etc., and for input/output test of operational units used exclusively with this product.

NOTE: "S/M" in the table denotes LINDBERGH RED service manual, which is provided separately.

TABLE 9

ITEMS	DESCRIPTION	REFERENCE SECTIONS
Game machine installation	1. Confirm that the Information Display Screen appears in normal fashion.	"S/M" Chapter 4
	2. Investigate each input device on the Input Test Screen.	"S/M" Chapter 4 & 9-3 B, E
	3. Investigate each output device on the Output Test Screen.	"S/M" Chapter 4 & 9-3 C
Periodic maintenance	1. Check settings.	"S/M" Chapter 4 & 9-3 D, E
	2. Test each input device on the Input Test Screen.	"S/M" Chapter 4 & 9-3 B, E
	3. Test each output device on the Output Test Screen.	"S/M" Chapter 4 & 9-3 C
Control problem	1. Investigate each input device on the Input Test Screen.	"S/M" Chapter 4 & 9-3 B, E
	2. Adjust or replace each input device.	Chapter 10 & 12
	3. If the problem persists, examine the mechanical components of each input device.	Chapter 10 & 12
Monitor problem	On the Monitor Adjustment Check Screen, check to be sure the monitor has been adjusted properly.	"S/M" Chapter 4 & Chapter 11
IC board problem	1. Information Display Screen	"S/M" Chapter 4
	2. Speaker Test	"S/M" Chapter 4
Date Check	Check data on game play times, histograms, etc., and adjust the level of difficulty.	9-3 G, D

9-1 SWITCH UNIT AND COIN METER

Switch Unit

In Test Mode, the switch unit in the coin chute door is operated. Unlock and open the coin chute door. Inside is a switch unit.

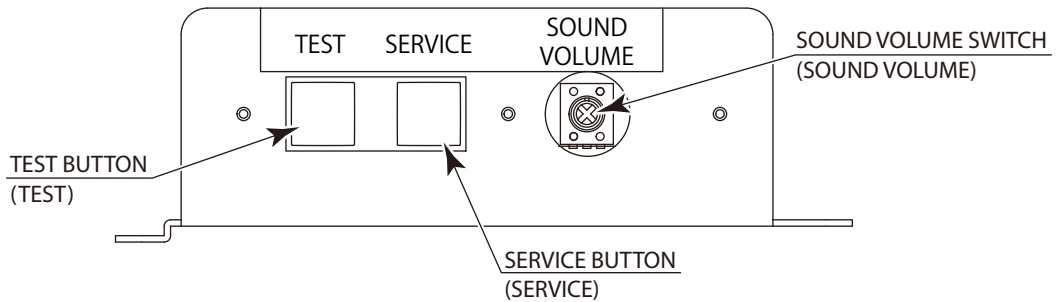

FIG. 9-1a Switch Unit

TEST Button (TEST)

Establishes Test Mode. Becomes the button to confirm selections in Test Mode.

SERVICE Button (SERVICE)

Makes it possible to enter credits for service without increasing the coin meter. Becomes the button to select items in Test Mode.

Sound Volume Switch (SOUND VOLUME)

This is the volume knob for speakers at the left and right of the control panel. Turn the knob to the right to increase speaker volume.

Coin Meter

After using a special-purpose key to unlock the cashbox door, the coin meter can be found at the bottom of the cashbox.

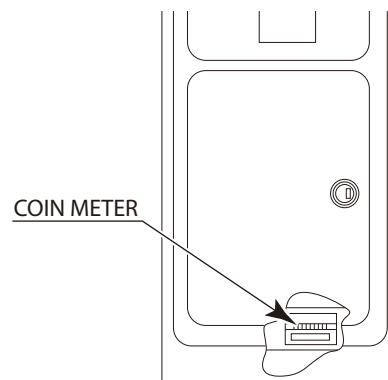

FIG. 9-1b Coin Meter

9-2 SYSTEM TEST MODE

STOP IMPORTANT

- The details of changes to Test Mode settings are saved when you exit from Test Mode by selecting EXIT from the system Test Mode menu. Be careful because if the power is turned off before that point, changes to the settings will be lost.
- Use with the specified settings. If settings other than those specified are used, inappropriate operations or malfunction may occur.

In the System Test Mode, the main activities include checking LINDBERGH RED information and actions and the setting of coin/credit. Also, a screen appears for checking screen adjustments. For details, see the LINDBERGH RED service manual, which is provided separately.

Use the following settings with this product. If the settings are not as specified, error messages might appear and operations might not be normal.

• COIN ASSIGNMENTS

COIN CHUTE TYPE: COMMON
SERVICE TYPE: COMMON

• NETWORK SETTING

NETWORK TYPE: MAIN
MAIN NETWORK: SETTING NOT REQUIRED

1 When the TEST Button is pressed, the System Test Menu Screen (SYSTEM TEST MENU) appears.

2 Use the SERVICE Button to move the cursor to the desired test item.

3 Press the TEST Button to confirm selection of the item.

4 When testing and checking are completed, select EXIT and press the TEST Button. The System Test Menu Screen reappears.

5 When all tests are completed, select EXIT and press the TEST Button. The Game Screen reappears.

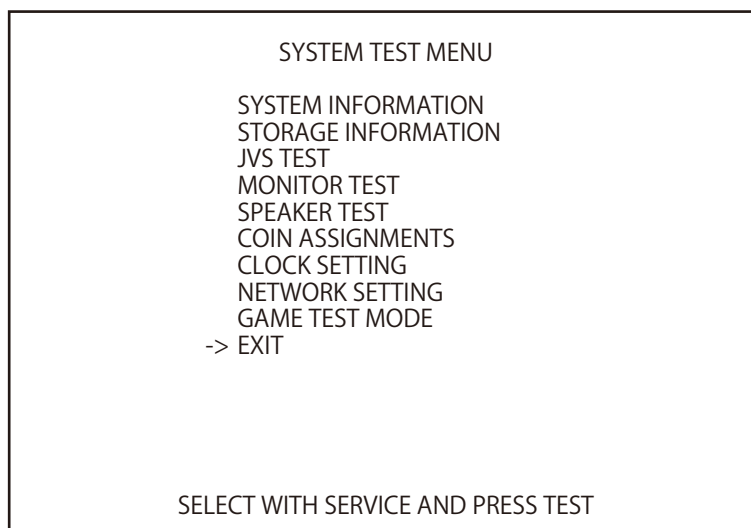

FIG. 9-2 System Test Menu Screen

9-3 GAME TEST MODE

STOP IMPORTANT

To change settings in the Game Test Mode, simply making changes on the setting screen will not be effective. Complete the Test Mode in normal fashion.

A. GAME TEST MENU

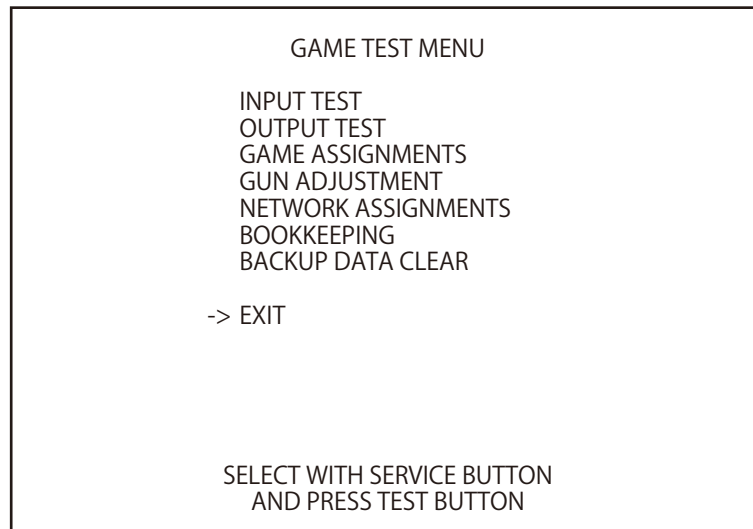

FIG. 9-3a

- 1 Select GAME TEST MODE from the System Test Menu Screen to display the Game Test Mode Screen as follows.
- 2 Use the SERVICE Button to move the cursor to the desired test item. Press the TEST Button to enter the selected item.
- 3 After the test is complete, move the cursor to EXIT and press the TEST Button to return to the System Test Menu Screen.

B. INPUT TEST

Select INPUT TEST to display the following screen and check the status of input devices. This test should be used periodically to check that each input device is functioning correctly.

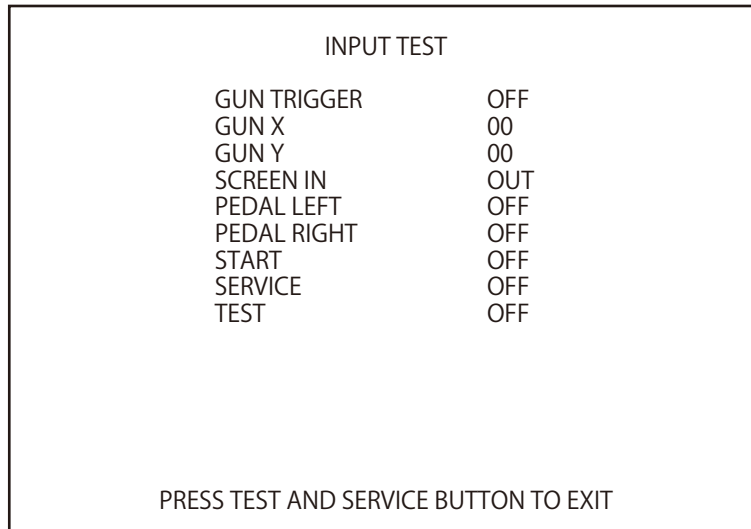

FIG. 9-3b

- 1 If the displays of the items change from "OFF" to "ON" when the respective button, trigger, or pedal is pressed, operation is normal.
Confirm operation of the gun by pointing it to the screen and moving it up, down, left, and right. (It can also be confirmed in GUN ADJUSTMENT.)

- 2 Press the SERVICE and TEST Buttons simultaneously to return to the Game Test Menu Screen.

GUN TRIGGER:	Turns "ON" when the gun's trigger is pulled.
GUN X:	Displays the gun's crosshair position along the X-axis. Has values of 00 through ff. (00 if off screen)
GUN Y:	Displays the gun's crosshair position along the Y-axis. Has values of 00 through ff. (00 if off screen)
SCREEN IN:	Turns "IN" if the gun's crosshair is on the screen.
PEDAL LEFT:	Turns "ON" when the left foot pedal is depressed.
PEDAL RIGHT:	Turns "ON" when the right foot pedal is depressed.
START:	Turns "ON" when the START Button is pressed.
SERVICE:	Turns "ON" when the SERVICE Button is pressed.
TEST:	Turns "ON" when the TEST Button is pressed.

C. OUTPUT TEST

This screen is for confirming the proper operation of each output device used by the game. Periodically use this screen to check the status of each output device.

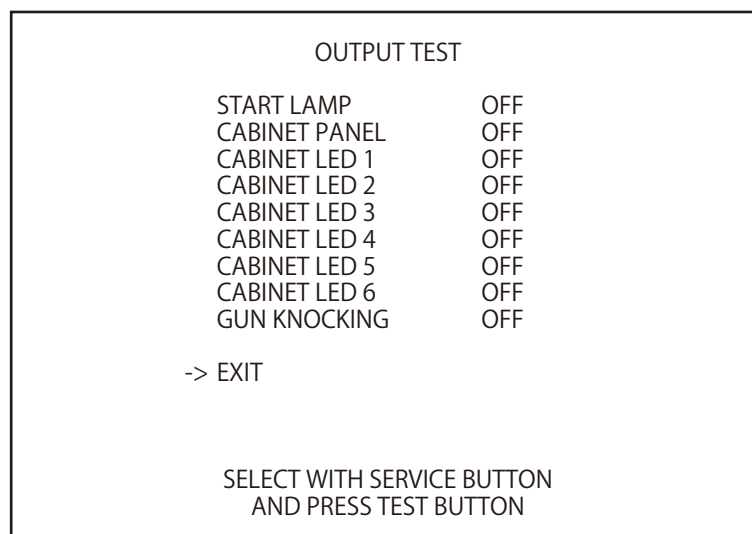

FIG. 9-3c

- 1 Use the SERVICE Button to move the cursor.
- 2 Move the cursor to the desired item and press the TEST Button.
Besides GUN KNOCKING, the output devices will change between ON and OFF when the TEST Button is pressed.
- 3 Move the cursor to EXIT and press the TEST Button to turn off all lamps and return to the Game Test Menu Screen.

START LAMP: While ON, the START Button will illuminate.

CABINET PANEL: While ON, the control panel will light up yellow.

CABINET LED: While ON, the control panel's LEDs will light up red. (1 - 6 from right)

GUN KNOCKING: The gun will recoil once for every press of the TEST Button.

D. GAME ASSIGNMENTS

This screen is for adjusting settings such as game difficulty.

When using NETWORK, the cabinet that is CABINET ID 2 will have its settings the same as CABINET ID 1's cabinet.

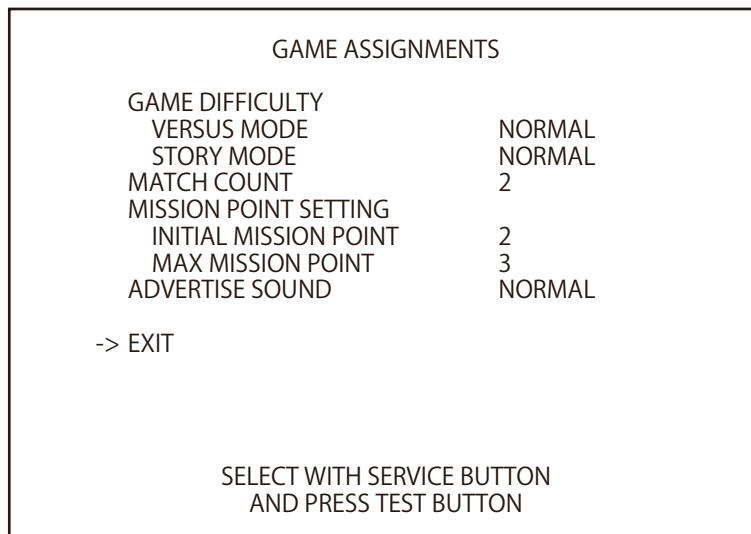

FIG. 9-3d

- 1 Use the SERVICE Button to move the cursor.
- 2 Move the cursor to the desired item and press the TEST Button.
- 3 Move the cursor to EXIT and press the TEST Button to return to the Game Test Menu Screen.

GAME DIFFICULTY:

Settings can be made for each mode.

There are five levels: VERY EASY / EASY / NORMAL / HARD / VERY HARD

(Default setting: NORMAL)

MATCH COUNT:

The number of winning rounds required for victory in Versus Mode. The range is from 1 to 4.

(Default setting: 2)

MISSION POINT SETTING INITIAL MISSION POINT:

The number of Mission Points players begin with in Story Mode. The range is from 1 to 6.

The value cannot be set higher than MAX MISSION POINT.

(Default setting: 2)

MISSION POINT SETTING MAX MISSION POINT:

The maximum number of Mission Points obtainable in Story Mode. The range is from 1 to 6.

(Default setting: 3)

ADVERTISE SOUND:

Set the sound during Attract Mode to ON or OFF.

There are five levels: NORMAL / "3/4" / "1/2" / "1/4" / OFF

(Default setting: NORMAL)

E. GUN ADJUSTMENT

This screen allows for the adjustment of the gun’s crosshair settings which are used during gameplay.

NOTE: Because of discrepancies between cabinets, be sure to adjust these settings prior to operating the cabinet for the first time.

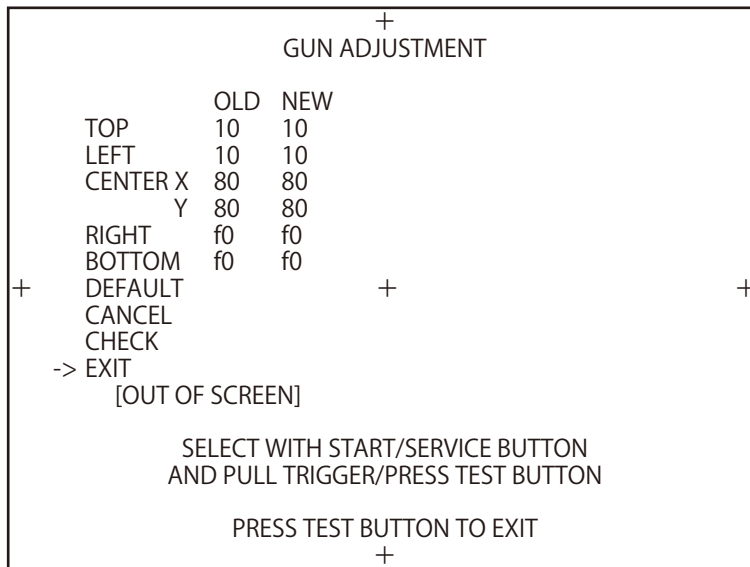

FIG. 9-3ea

- 1 Use the START Button to move the cursor.
- 2 Move the cursor to the desired item and pull the gun’s trigger.
- 3 Move the cursor to EXIT and press the TEST Button to update and save modified items, and return to the Game Test Menu Screen.

Each item’s OLD value represents its value as adjusted prior to entering this mode, and the NEW value represents what will now be set.

When the gun is pointed away from the screen, “OUT OF SCREEN” will be displayed.

TOP:

Sets the adjustment value vertically at its highest point.

Aim the gun at the “+” mark on the upper edge of the screen, pull the trigger, and the NEW adjustment value will be updated.

LEFT:

Sets the adjustment value horizontally at its leftmost point.

Aim the gun at the “+” mark on the left edge of the screen, pull the trigger, and the NEW adjustment value will be updated.

CENTER:

Sets the adjustment value for the center of the screen.

Aim the gun at the “+” mark in the center of the screen, pull the trigger, and the NEW adjustment value will be updated.

RIGHT:

Sets the adjustment value horizontally at its rightmost point.

Aim the gun at the “+” mark on the right edge of the screen, pull the trigger, and the NEW adjustment value will be updated.

BOTTOM:

Sets the adjustment value vertically at its lowest point.

Aim the gun at the “+” mark on the bottom edge of the screen, pull the trigger, and the NEW adjustment value will be updated.

DEFAULT:

When chosen, this sets the adjustment values to their default settings (when shipped from factory).

CANCEL:

When chosen, all current changes made to values will be erased, and the adjustment values will return to their previous values.

CHECK:

Point the gun at the screen to check the crosshair at currently changed adjustment values.

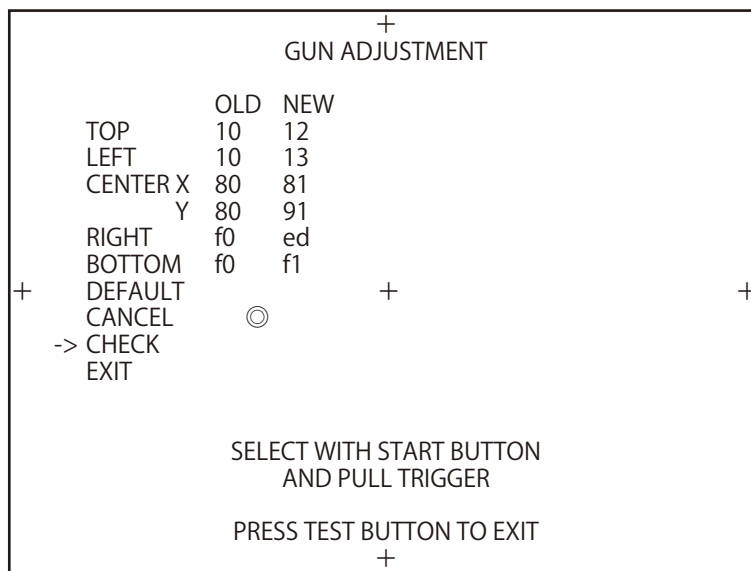

FIG. 9-3eb

Use the crosshair that is displayed on the screen to verify that the gun can be aimed all the way to each of the screen's edges.

If the crosshair aligns properly with the marks, move the cursor to EXIT and press the TEST Button to save the changes and return to the Game Test Menu Screen.

If the crosshair does not align properly with the marks, adjust the values once again.

F. NETWORK ASSIGNMENTS

This screen is for setting the cabinets' IDs and the communication method between cabinets.

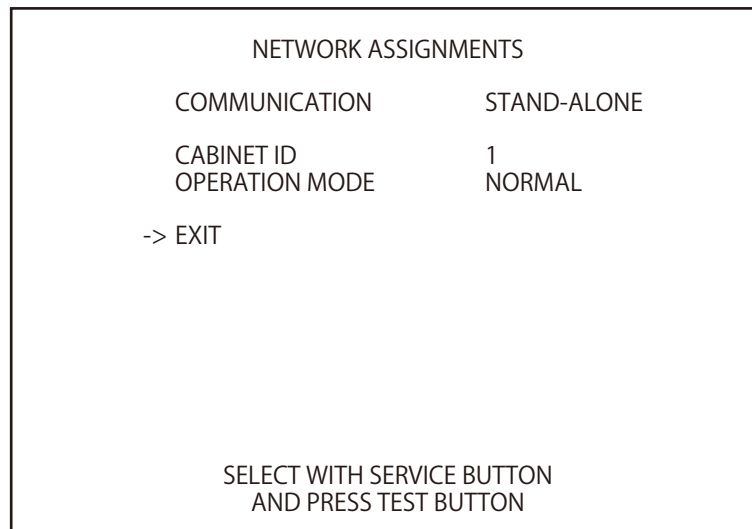

FIG. 9-3f

- 1** Use the SERVICE Button to move the cursor.
- 2** Move the cursor to the desired item and press the TEST Button.
- 3** Move the cursor to EXIT and press the TEST Button to return to the Game Test Menu Screen.

COMMUNICATION:

The communication method. When two cabinets will be operated in tandem, choose "NETWORK". When the respective cabinets will operate alone, choose "STAND-ALONE".

CABINET ID:

The cabinet's ID (also Player ID). Either 1 or 2.

When operating two cabinets in tandem, choose a different setting for each cabinet.

If the settings are the same for both cabinets, there will be a communications error.

OPERATION MODE:

The operation mode can be set to "NORMAL" or "EVENT."

When set to "EVENT", only Versus Mode can be played, and the game will be over after one match.

Two settings: NORMAL / EVENT

(Default setting: NORMAL)

G. BOOKKEEPING

The following screens display information regarding the game's operational records.

There are four screens in all that display up-to-date data.

When the TEST Button is pressed, the next screen will be shown.

Press the TEST Button while on the fourth screen to return to the Game Test Menu Screen.

BOOKKEEPING		PAGE 1/4
COIN 1	0	
COIN 2	0	
TOTAL COINS	0	
COIN CREDITS	0	
SERVICE CREDITS	0	
TOTAL CREDITS	0	
PRESS TEST BUTTON TO CONTINUE		

FIG. 9-3ga

- COIN 1, 2:** The number of coins inserted in each coin chute.
- TOTAL COINS:** The total number of coins inserted in all coin chutes.
- COIN CREDITS:** The number of credits added by inserting coins.
- SERVICE CREDITS:** The number of credits added by pressing the SERVICE Button.
- TOTAL CREDITS:** The total number of credits.

When the TEST Button is pressed, the next screen will be shown.

BOOKKEEPING		PAGE 2/4
NUMBER OF GAMES		0
VERSUS MODE		0
STORY MODE		0
NUMBER OF CONTINUE		0
VERSUS MODE		0
STORY MODE		0
TOTAL TIME	0D 00H 00M 00S	
PLAY TIME	0D 00H 00M 00S	
VERSUS MODE	0D 00H 00M 00S	
STORY MODE	0D 00H 00M 00S	
AVERAGE PLAY TIME	00M 00S	
VERSUS MODE	00M 00S	
STORY MODE	00M 00S	
LONGEST PLAY TIME	00M 00S	
VERSUS MODE	00M 00S	
STORY MODE	00M 00S	
SHORTEST PLAY TIME	00M 00S	
VERSUS MODE	00M 00S	
STORY MODE	00M 00S	
PRESS TEST BUTTON TO CONTINUE		

FIG. 9-3gb

- NUMBER OF GAMES:** The total number of games played.
- NUMBER OF CONTINUE:** The total number of continued games played.
- TOTAL TIME:** The total time the cabinet has been turned on.
- PLAY TIME:** The time spent in games.
- AVERAGE PLAY TIME:** The average time of one play.
- LONGEST PLAY TIME:** The time of the longest single play.
- SHORTEST PLAY TIME:** The time of the shortest single play.

NOTE: NUMBER OF GAMES, NUMBER OF CONTINUE, PLAY TIME, AVERAGE PLAY TIME, LONGEST PLAY TIME, and SHORTEST PLAY TIME are counted for each game mode.

When the TEST Button is pressed, the next screen will be shown.

BOOKKEEPING		PAGE 3/4
GAME HISTOGRAM (VERSUS MODE)		
0M00S - 0M29S	0	
0M30S - 0M59S	0	
1M00S - 1M29S	0	
1M30S - 1M59S	0	
2M00S - 2M29S	0	
2M30S - 2M59S	0	
3M00S - 3M29S	0	
3M30S - 3M59S	0	
4M00S - 4M29S	0	
4M30S - 4M59S	0	
5M00S - 5M29S	0	
5M30S - 5M59S	0	
6M00S - 6M29S	0	
6M30S - 6M59S	0	
7M00S - 7M29S	0	
7M30S - 7M59S	0	
8M00S - 8M29S	0	
8M30S - 8M59S	0	
9M00S - 9M29S	0	
9M30S - 9M59S	0	
OVER 10M00S	0	
PRESS TEST BUTTON TO CONTINUE		

FIG. 9-3gc

The GAME HISTOGRAM displays how many times a play ended at a certain time on that cabinet. Use this as a reference when determining settings such as difficulty level.

When the TEST Button is pressed, the next screen will be shown.

BOOKKEEPING		PAGE 4/4
GAME HISTOGRAM (STORY MODE)		
0M00S - 0M29S	0	
0M30S - 0M59S	0	
1M00S - 1M29S	0	
1M30S - 1M59S	0	
2M00S - 2M29S	0	
2M30S - 2M59S	0	
3M00S - 3M29S	0	
3M30S - 3M59S	0	
4M00S - 4M29S	0	
4M30S - 4M59S	0	
5M00S - 5M29S	0	
5M30S - 5M59S	0	
6M00S - 6M29S	0	
6M30S - 6M59S	0	
7M00S - 7M29S	0	
7M30S - 7M59S	0	
8M00S - 8M29S	0	
8M30S - 8M59S	0	
9M00S - 9M29S	0	
9M30S - 9M59S	0	
OVER 10M00S	0	
PRESS TEST BUTTON TO EXIT		

FIG. 9-3gd

Press the TEST Button to return to the Game Test Menu Screen.

H. BACKUP DATA CLEAR

Select BACKUP DATA CLEAR to display the following screen, and you can clear the bookkeeping data.

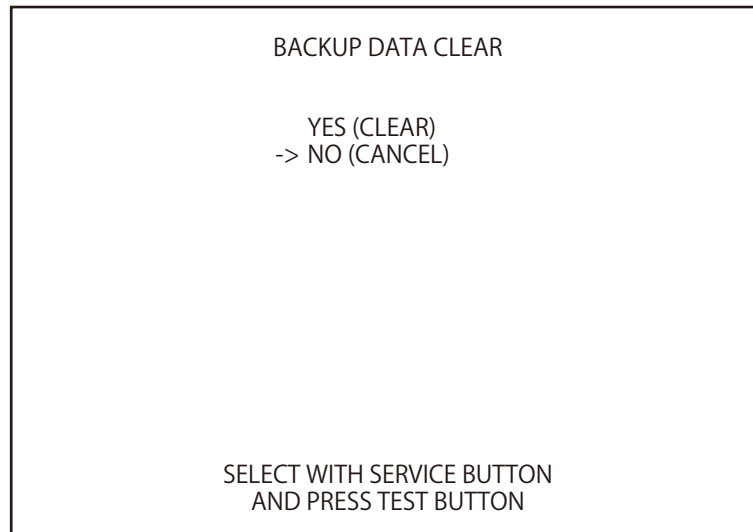

FIG. 9-3ha

To clear data, use the SERVICE Button to move the cursor to YES (CLEAR) and then press the TEST Button. When the data has been cleared, the message "COMPLETED" will be displayed.

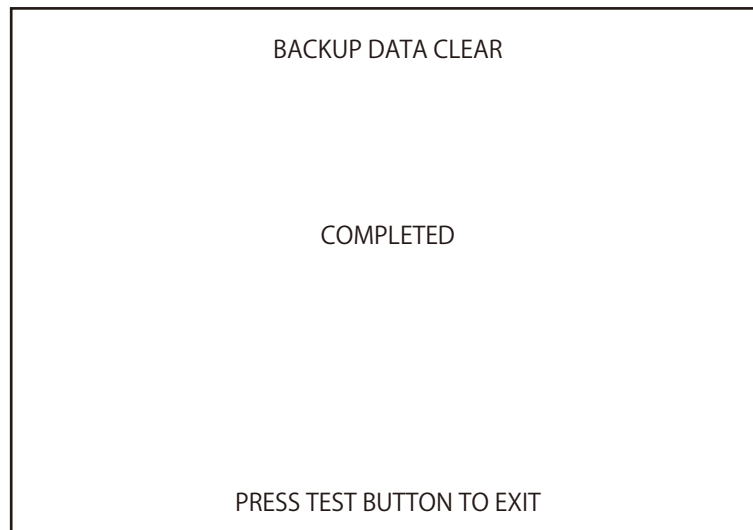

FIG. 9-3hb

Press the TEST Button again to return to the Game Test Menu Screen.

Move the cursor to NO (CANCEL) and press the TEST Button to return to the Game Test Menu Screen without clearing the data.

Using the functions of this screen to clear backup data will not clear GAME ASSIGNMENTS settings.

10 CONTROL UNIT (GUN)

WARNING

- When working with the product, be sure to turn the power off. Working with the power on may cause an electric shock or short circuit.
- Be careful not to damage the wires. Damaged wires may cause an electric shock, short circuit or present a risk of fire.
- Exercise due caution in performing soldering work. If soldering iron is handled carelessly, there could be fires or burns.

CAUTION

- When fastening plastic parts, be careful not to tighten screws or nuts excessively. If these are tightened to excess, parts could be damaged, resulting in injuries from fragments, etc.
- After the unit has been disassembled and reassembled again, check carefully to be sure that there are no gaps or rattling at the junctions and that the trigger can be operated smoothly. If there are gaps or rattling, or if operation is not satisfactory, the players could get fingers or hands caught, resulting in injury.
- Be sure to inspect gun surfaces for cracks and damage. Players could be injured if they play when the unit is cracked or damaged.
- Assemble so that there is no gap between the L and R covers. If there is a gap or rattling, the players could get fingers or hands caught, resulting in injury.

IMPORTANT

- Once the product has been disassembled, use slack preventive agent (product No. : 090-0012-N). Coat screws with suitable amounts of this agent and then tighten them. If this agent is not used, the product might start rattling or come apart.
- Use the slack preventive agent prescribed in these instructions. If any other agent is used, there could be chemical changes that inhibit the use of screws and part surfaces could be damaged.
- Be careful not to damage or lose small parts or screws.
- When a part has been replaced, be sure to always make adjustments and check conditions in Test Mode.

If the gun does not operate satisfactorily and adjustments in Test Mode are ineffective, it could be that parts inside the gun have been damaged.

Follow the steps given below to remove the gun, then take it apart and replace parts.

To replace parts in the gun, detach the L and R covers of the outer part.

Because internal parts are inserted on the R cover side, work with the R cover facing downward.

Microswitch Replacement

- 1 Three kinds of screws are used to fasten the L and R covers. The L and R covers can be detached by removing all ten of these screws.

SCREW (8), black
M3 x 12, w/ small flat & spring washers

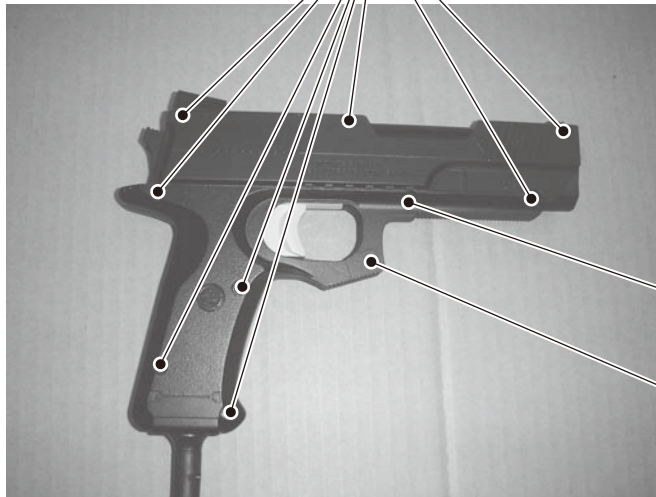

SCREW (1), black
M3 x 10, w/ small flat & spring washers

COUNTERSUNK-HEAD SCREW (1), black
M3 x 8

FIG. 10a

- 2 With the R cover on the bottom, remove the L cover by slowly lifting it straight up.

- 3 Remove the trigger microswitch from the R cover.

MICROSWITCH
509-5080

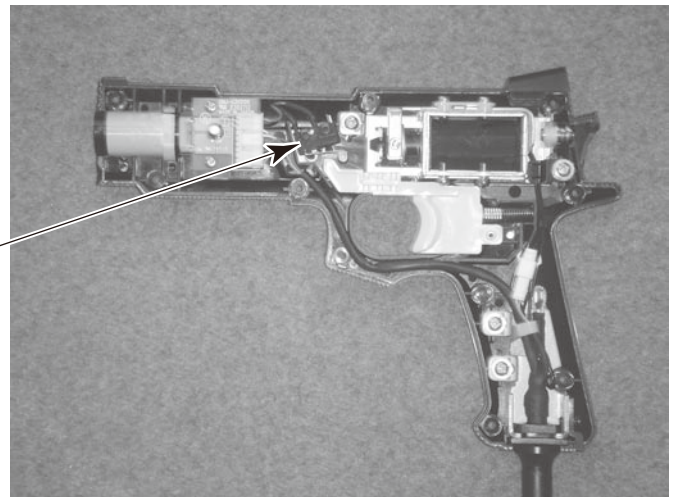

FIG. 10b

- 4 Remove the soldered part and then remove the microswitch.
- 5 Solder the new microswitch. Employ heat shrinkable tubing to protect the soldered part. Reassemble the gun. Operate the trigger to fully verify that the microswitch turns on and off properly. Then, reattach the L cover to the R cover. Do not tighten the screws excessively.
- 6 After replacing the microswitch, refer to the section titled "GAME TEST MODE". Conduct an Input Test.

Sensor Unit Replacement

1 Remove the L cover following the same procedures used when replacing a microswitch.

2 Remove the connector and then remove the sensor unit.

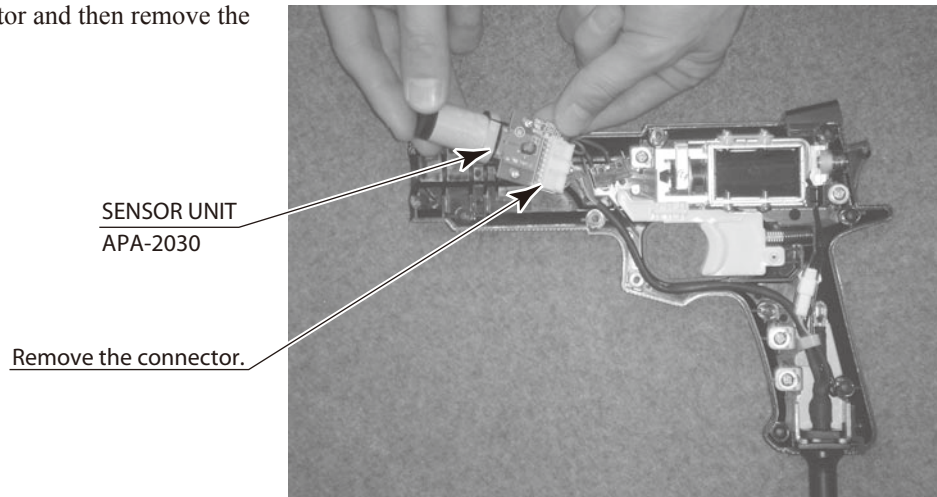

FIG. 10c

3 After replacing the sensor unit, reassemble the gun. Operate the trigger to fully verify that the microswitch turns on and off properly. Then, reattach the L cover to the R cover.

4 After replacing the sensor unit, refer to the section titled "GAME TEST MODE". Conduct a Gun Adjustment Test.

Solenoid Replacement

1 Remove the L cover following the same procedures used when replacing a microswitch.

2 Remove the cord clamp fastening the cable and remove the connector.

Remove the connector.

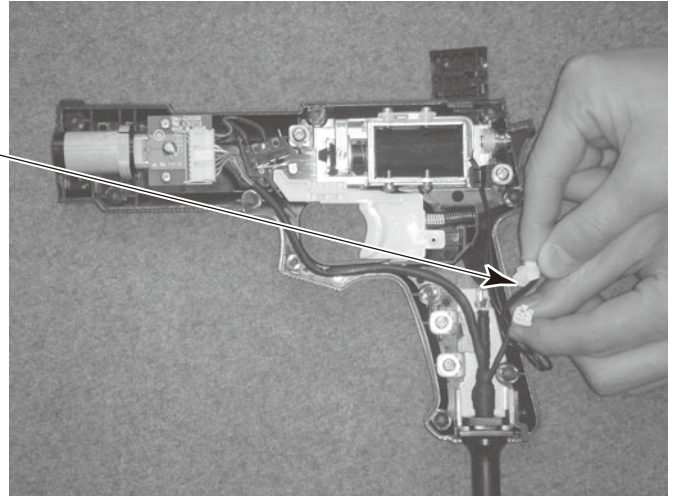

FIG. 10d

3 Remove the two screws and remove the solenoid ASSY.

SOLENOID ASSY

SCREW (2)
M4 x 8, w/flat & spring washers

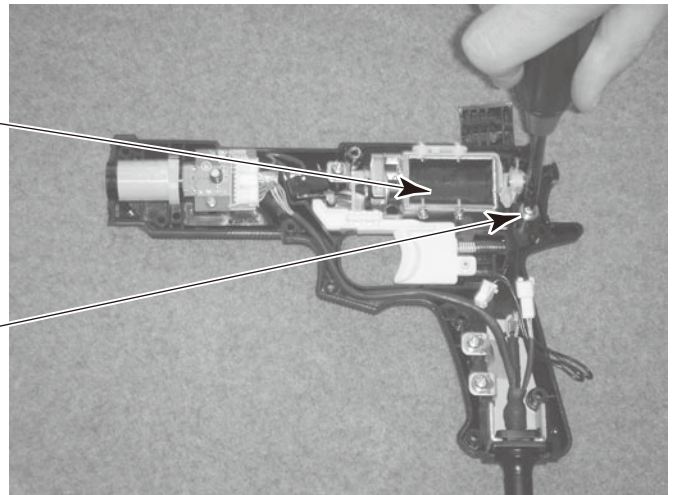

FIG. 10e

4 Pay special attention to spring washers and other small parts when removing the solenoid.

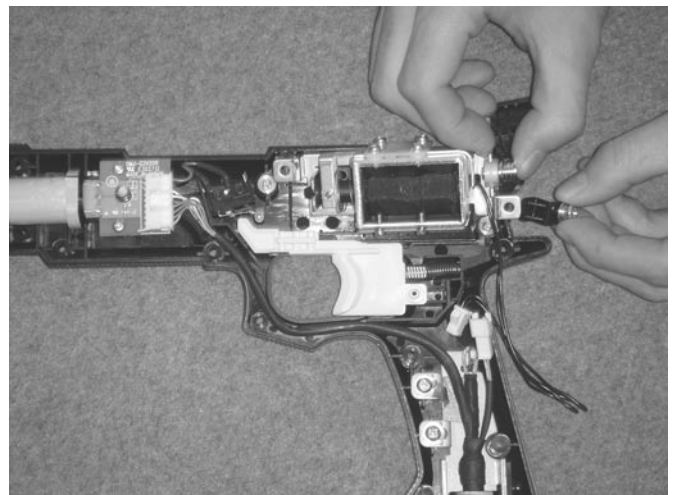

FIG. 10f

-
- 5** Remove the eight screws and an E-ring (2 mm), and replace the solenoid. Be careful not to lose small parts during this procedure.

SCREW (8)
M3 x 6, w/spring washer

SOLENOID
124-5101

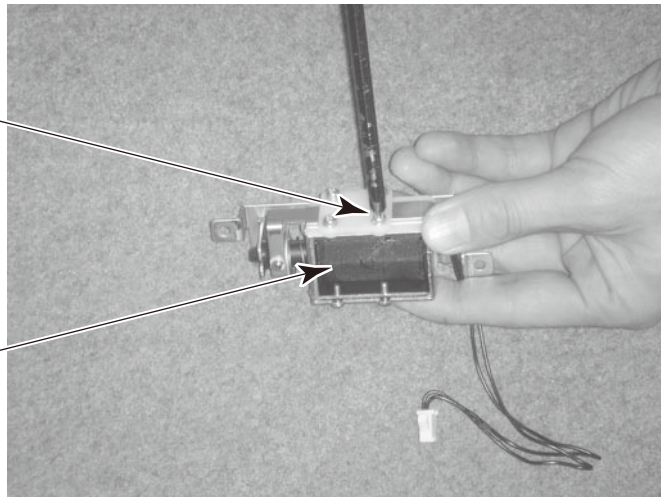

FIG. 10g

E-RING
2 mm

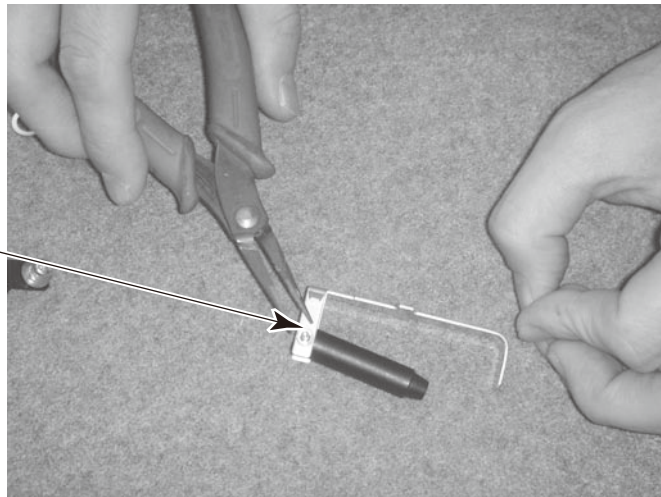

FIG. 10h

-
- 6** Attach the solenoid ASSY with two screws and connect the connector. Be careful not to damage the wiring.

-
- 7** Refer to the preceding sections regarding part replacement. Reattach the L cover, handling each part with appropriate care.

-
- 8** After replacing the solenoid, refer to the section titled GAME TEST MODE. Conduct an Output Test.

11 MONITOR (LCD DISPLAY)

11-1 SAFETY PRECAUTIONS WHEN HANDLING THE MONITOR

WARNING

Responding to breakdown or abnormality

- If smoke or a strange odor appears, immediately unplug the power cable from the power source.

Continuing to use the product may cause a fire or an electric shock. Ensure that smoke is no longer emitted, and contact the point of purchase.

- If nothing displays on the screen, immediately unplug the power cable from the power source.

Continuing to use the product may cause a fire or an electric shock. Contact the point of purchase and request an inspection.

- If water or a foreign object enters the monitor's interior, immediately unplug the power cable from the power source.

Continuing to use the product may cause a fire or an electric shock. Contact the point of purchase and request an inspection.

- If the monitor is dropped or the cabinet is damaged, immediately unplug the power cable from the power source.

Continuing to use the product may cause a fire or an electric shock. Contact the point of purchase and request an inspection.

During operation

- Do not repair, reconstruct, or disassemble the monitor.

The monitor's interior contains high voltage parts. A fire or an electric shock could result.

For inspections, adjustments, and repair of the monitor's interior, request work from the point of purchase.

- Do not insert foreign objects.

If metal objects or flammable materials such as paper are inserted into the interior through ventilation openings or other apertures, an electric shock could result.

- In the event of a thunder storm, do not touch the product or the power cable. An electric shock could result.

- Make sure to perform appropriate adjustments. Do not operate the product when the screen is flickering, distorted, or experiencing other abnormalities. Images from an improperly adjusted screen could cause players and other customers to experience dizziness, headaches, and other ailments.

11-2 CLEANING THE SCREEN SURFACE

CAUTION

- Use a soft, dry cloth (flannel-type) to wipe away dirt. Do not use materials such as coarse mesh gauze.
- Alcohol (ethanol) is the recommended solvent for removing dirt. When using a cleaning agent, follow the precautions below.
 - Dilute neutral cleaning agents for home use with water. Soak a soft cloth in the solution, and wring it thoroughly before wiping the screen.
 - Do not use abrasive cleaning agents or powders, or cleaning agents containing bleach.
 - Do not use alkaline cleaning agents such as glass cleaners, or solvents such as thinners.
- Do not scrub or scratch the screen surface with abrasive materials such as brushes or scrub brushes.

Clean the screen surface once a week.

11-3 ADJUSTMENT METHOD

STOP IMPORTANT

All adjustment values are set accurately at the time of shipping from the factory. Do not readjust these values needlessly or apply adjustments not specified in this manual. The display may not appear properly if the values are incorrect.

Controls – Adjustment Procedures

This section explains basic control procedures for making adjustments using the buttons on the monitor adjustment board. Remove the two truss screws from the front cabinet. Remove the front cover to access the monitor adjustment board.

TRUSS SCREW (2), black
M4 x 8

FRONT COVER

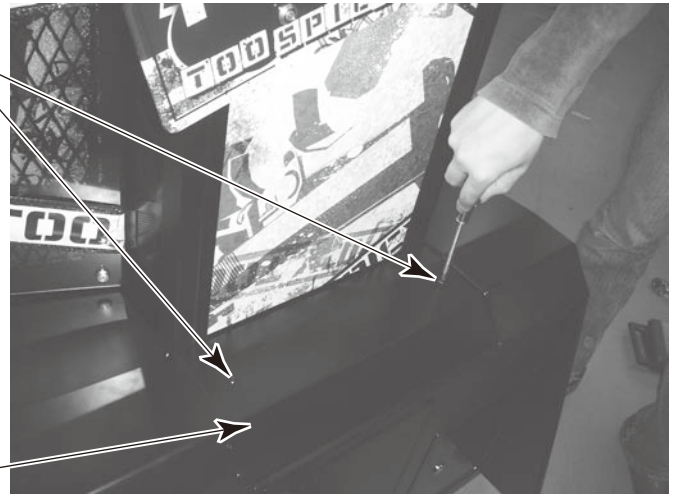

FIG. 11-3a

MONITOR ADJUSTMENT BOARD



FIG. 11-3b

Button Names and Functions

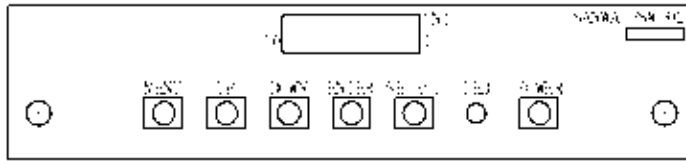

FIG. 11-3c

MENU:

Turn the Picture Menu display on and off.

UP:

Move the cursor up to highlight a menu item.
Increase the value of, or change, a selected menu item.

DOWN:

Move the cursor down to highlight a menu item.
Decrease the value of, or change, a selected menu item.

ENTER:

Select, or execute, a highlighted menu item.

SELECT:

Turn off the Picture Menu, and change the input type (either Analog RGB or DVI).
Each time the SELECT Button is pressed, the input type changes as follows.
(---Analog RGB → DVI → Analog RGB---)

LED:

LED illuminates green: Monitor is operating.
LED flashes red: Power is off.

POWER:

Turn the LCD monitor on and off. (Usually, it's not necessary to operate.)

On-Screen Display (OSD)

Press the MENU Button while the OSD is not displayed to bring up the Picture Menu. On the Picture Menu, it is possible to perform various screen adjustments.

Use the UP and DOWN Buttons to highlight the item you want to adjust.

After highlighting the desired item, press the ENTER Buttons to select and begin the adjustment.

Within each item, press the MENU Buttons to exit the adjustment screen. The adjustment values at this time will be saved simultaneously.

NOTE: H POSITION and V POSITION only function when the input type is Analog RGB.

BRIGHTNESS	050
CONTRAST	050
COLOR TEMP	NORMAL
H POSITION	***
V POSITION	***
BACKLIGHT	010
AUTO ADJUST	PRESS ENTER

FIG. 11-3d Picture Menu Screen

Available Settings

- **BRIGHTNESS (adjust brightness)**

Adjust screen brightness.

Values: 0 - 100 (“0” being the darkest setting, and “100” being the brightest)

- **CONTRAST (adjust contrast)**

Adjust contrast level.

Values: 0 - 100 (“0” having the least amount of difference between light and dark, and “100” having the most)

- **COLOR TEMP (adjust color)**

Adjust screen color. The following three color schemes are available.

Settings: COOL/NORMAL/WARM

- **H POSITION (adjust horizontal position)**

(only available when the input type is Analog RGB)

When the screen position does not fit even if performing the AUTO ADJUST setting, adjust the horizontal position of screen images.

Values: 0 - 999 (The screen moves to the left with UP Button, and move to the right with DOWN Button.)

- **V POSITION (adjust vertical position)**

(only available when the input type is Analog RGB)

When the screen position does not fit even if performing the AUTO ADJUST setting, adjust the vertical position of screen images.

Values: 0 - 999 (The screen moves upward with UP Button, and move downward with DOWN Button.)

- **BACKLIGHT (adjust backlight)**

Adjust the backlight.

Values: 0 - 10 (“0” being the darkest setting, and “10” being the brightest)

- **AUTO ADJUST (adjust screen automatically)**

Automatically adjusts the screen position based on the video input signal.

12 COIN SELECTOR

When the REJECT button fails to refund coins, open the coin chute door and open the selector gate. Once the jammed coin is removed, insert a standard coin to ensure that the selector is working properly.

Cleaning the Coin Selector

STOP IMPORTANT

- Remove and clean smears using a soft cloth dipped in water or diluted chemical detergent which is then wrung dry.
- Never apply machine oil, etc. to the coin selector.
- After cleaning the coin selector, properly insert a standard coin to ensure that the selector functions correctly.

The coin selector should be cleaned once every 3 months. When cleaning, follow the procedures below:

1 Turn off game unit power supply. Open coin chute door.

2 Remove coin selector from coin chute door.

3 Open gate and wipe away dirt with animal hairbrush or other soft brush.

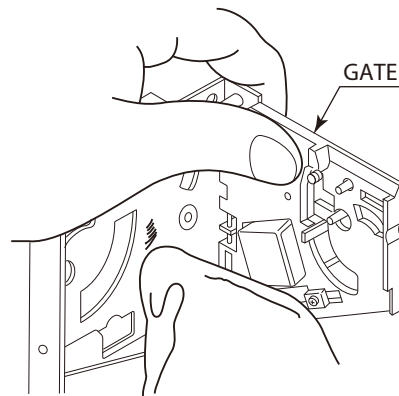

FIG. 12a

4 Soak a soft cloth in water or in a neutral cleaning agent diluted with water, wring it tightly and wipe away dirt.

5 Remove cradle. When removing the retaining ring (E ring), be careful not to bend the rotary shaft.

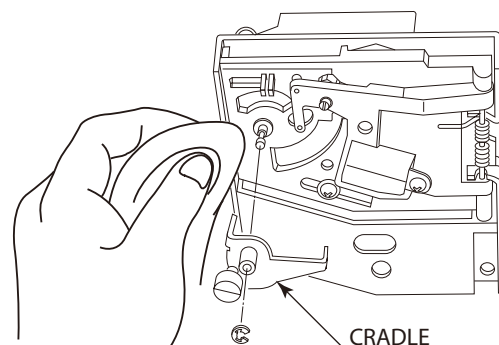

FIG. 12b

6 Use soft cloth to wipe dirt from rotary shaft and bearing.

7 After wiping off dirt, wipe away moisture with a dry cloth and make sure that the coin selector is completely dry.

Coin Insertion Test

Carry out a coin insertion test once per month. At the same time, check the following points:

- Does the coin meter count properly?
- Do coins drop into the cashbox correctly?
- Are coins rejected when inserted while holding down the REJECT button?

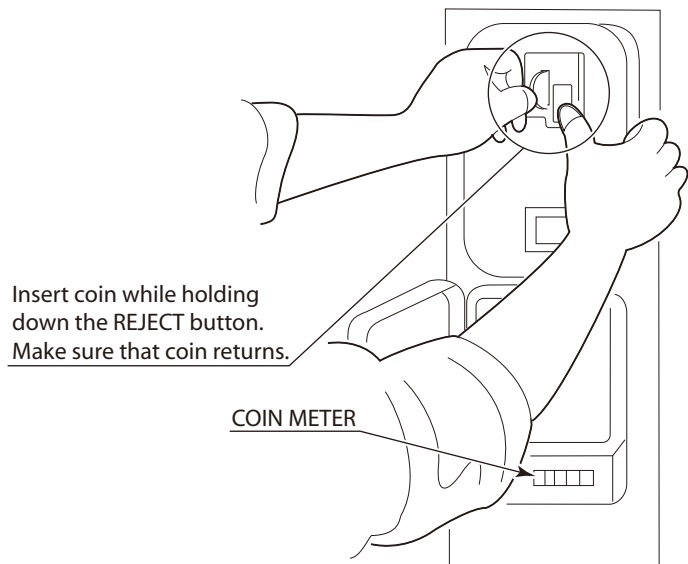

FIG. 12c

13 FLUORESCENT LAMP REPLACEMENT

⚠ WARNING

- When working with the product, be sure to turn the power off. Working with the power on may cause an electric shock or short circuit.
- There is danger that hot lamps can cause burns. Exercise due caution when replacing lamps.
- Use lamps of the specified ratings. Using lamps with different ratings may cause fires or damage.
- Such things as deteriorated insulation in lighting fixtures can cause a short circuit and/or smoke. Make sure there are no abnormalities. For example, check if you can smell anything burning, if any sockets have been discolored and if the lamp has to be replaced frequently.

⚠ CAUTION

Be careful when handling parts made of plastic or glass. For example, be careful not to tighten screws excessively. If such parts are damaged, injuries could be caused by fragments, cracks, etc.

Fluorescent Lamp Inside Front Cabinet

1 Turn off the power.

2 Remove the six truss screws from the back of the front cabinet.

TRUSS SCREW (6), black
M4 x 8

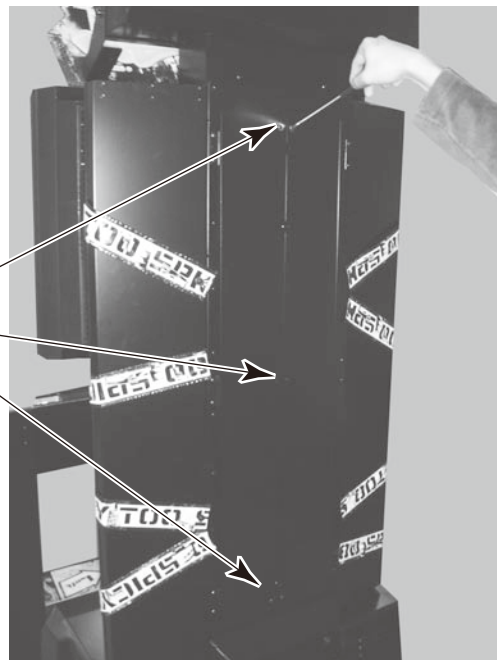

FIG. 13a

- 3 Open the rear lid of the front cabinet. Replace the fluorescent lamp.

FLUORESCENT LAMP 32 W: 390-5251-32-01
 GLOW LAMP: 390-5638-5P

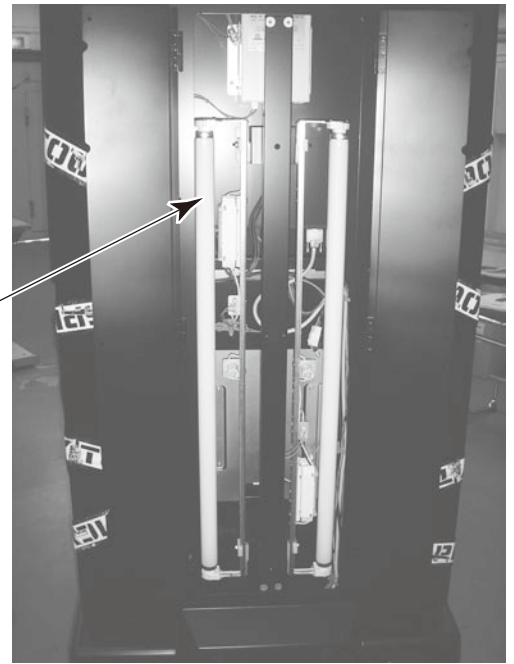

FIG. 13b

Fluorescent Lamp Inside Billboard

- 1 Turn off the power.
- 2 Remove the billboard from the front cabinet. Place it on the floor before performing any work.
- 3 Remove a total of four hexagon bolts from the sides of the billboard.

HEXAGON BOLT (total 4), black
 M6 x 16, w/spring washer, large flat washer used



FIG. 13c

4 Remove the plate holder.

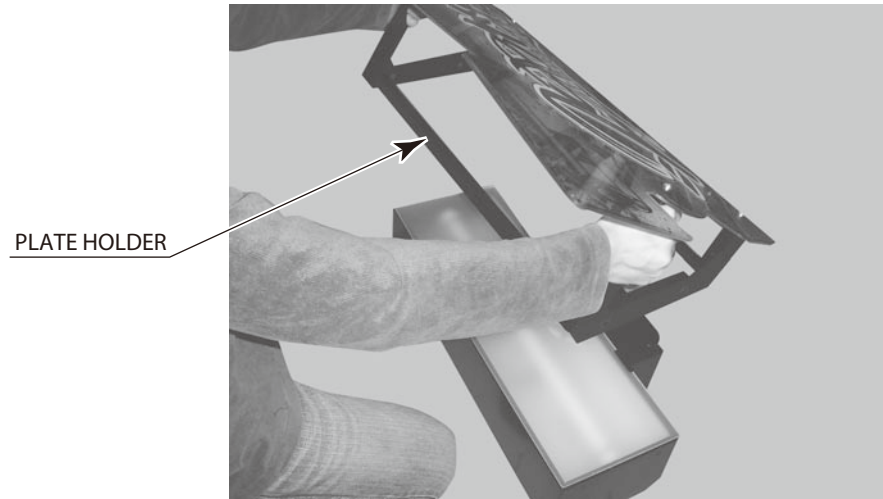

FIG. 13d

5 Remove the lamp cover. Replace the fluorescent lamp.

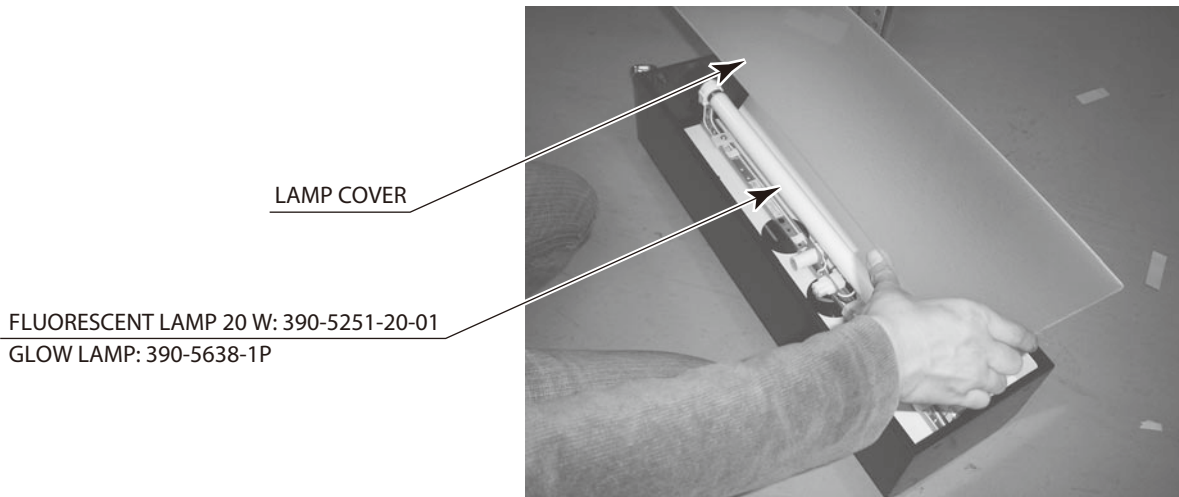



FIG. 13e

14 PERIODIC INSPECTION

The items listed below require periodic check and maintenance to retain the performance of this machine and to ensure safe business operation.

Players operate the gun by touching it and holding it with their hands. Clean the gun on a regular basis and have hand wipes, etc. available to ensure that players will always fully enjoy the game.

 WARNING

- **Be sure to check once a year to see whether power cords are damaged, the plug is securely inserted, dust has accumulated between the socket outlet and the power plug, etc. Using the product with accumulated dust can cause fire and electric shock.**
- **Never use a water jet, etc. to clean inside and outside the cabinet. If the machine gets wet for any reason, do not use it until it has completely dried.**
- **Periodically, around once a year, get in touch with the place of contact herein stated or the distributor, etc. where the product was purchased from, regarding internal cleaning. Using the product with accumulated dust in the interior can cause a fire or accident. Note that professional cleaning will require a fee.**
- **There is the danger of accidents involving electrical shorts circuits or fire caused by factors such as the deterioration of insulation in electrical and electronic equipment over time. Check that there are no abnormalities such as odors from burning.**

TABLE 14 PERIODIC INSPECTION TABLE

ITEMS	DESCRIPTION	PERIOD	REFERENCE
CABINET	Confirm that adjusters contact floor	Daily	3, 6, 7
MONITOR (LCD DISPLAY)	Screen cleaning	Weekly	11
	Check screen adjustment	Monthly	11
GUN CONTROL UNIT	Cleaning, Inspection	Daily	10
	Check gun adjustment	Weekly	9,10
	Microswitch test	Monthly	9,10
	Inspection of solenoid	Monthly	9,10
COIN SELECTOR	Coin insertion test	Monthly	12
	Cleaning	Every 3 months	12
FLUORESCENT LAMPS	Inspection of lighting fixtures	As appropriate	13
ELECTRICAL/ELECTRONIC PARTS	Inspection	As appropriate	As above
CABINET INTERIOR	Cleaning	1 year	As above
POWER CABLE	Inspection, Cleaning	1 year	As above
CABINET SURFACES	Cleaning	As appropriate	See below

Cleaning the Cabinet Surfaces

When the cabinet surfaces become dirty, remove stains with a soft cloth soaked in water or diluted (with water) chemical detergent and then wrung dry. To avoid damaging the finish, do not use such solvents as thinner, benzene, etc. (other than ethyl alcohol) or abrasives (bleaching agent and chemical dust-cloth).

Some general-purpose household, kitchen, and furniture cleaning products may contain strong solvents that degrade plastic parts, coatings, and print. Before using any cleaning product, read the product's cautionary notes carefully and test the product first on a small area that is not highly visible.

15 TROUBLESHOOTING

15-1 TROUBLESHOOTING TABLE

WARNING

- The work described below should be carried out by the site maintenance personnel or other qualified professional. Work carried out by personnel without the necessary skill or technology can cause accident.
- If no improvements can be noted even after the following measures have been taken, disengage the power and contact the point of purchase or the office indicated in these instructions. If the power is left on while there is an abnormality, a fire, electric shock or other serious accident can occur.
- When working with the product, be sure to turn the power off. Working with the power on may cause an electric shock or short circuit.
- Be careful not to damage the wires. Damaged wires may cause an electric shock, short circuit or present a risk of fire.
- Once the reason that the breaker or circuit protector activated has been removed, restore the breaker or circuit protector to its original condition. If the product is used while the reason for activation has not yet been removed, heat and/or fire could be generated.

If a problem occurs, first inspect the connection of any wiring connectors.

TABLE 15-1a

PROBLEMS	CAUSE	COUNTERMEASURES
With main switch ON, no activation.	Power is not supplied.	Securely insert the power plug into the plug socket.
	Power supply/voltage is not correct.	Make sure that power supply/voltage is correct.
	The circuit protector functioned due to the momentary overload.	After eliminating the cause of overload, reinstate the AC unit's circuit protector. < See chapter 6, [7], refer to the following.>
No sound is generated from the speaker.	Faulty adjustment of sound volume.	Adjust the sound volume. <See chapter 9.>
	Faulty wiring connection.	Check with speaker test in Test Mode. Then check connections of speakers that do not produce sound. <See the LINDBERGH RED Service Manual.>
The monitor screen's hue/saturation and/or brightness are unnatural.	Faulty connection of video signal connector.	Make sure that the video signal connector is properly connected and fastened.
The monitor screen does not display the correct colors.	Faulty connection of video signal connector.	Make sure that the video signal connector is properly connected and fastened. Also, verify that the connector's metal parts are not in contact with any of the cabinet's metal parts.
	Faulty screen adjustment.	Perform appropriate adjustments. <See chapter 11.>

TABLE 15-1b

PROBLEMS	CAUSE	COUNTERMEASURES
Gun crosshair is misaligned.	Faulty gun adjustment.	Adjust settings on the Gun Adjustment Screen in Test Mode. <See chapter 9.>
	Screen LED sensor board malfunction.	Contact the point of purchase for this product.
	Gun sensor board is damaged.	Replace sensor board. <See chapter 10.>
	Faulty wiring connection.	Make sure that wiring between the front and rear cabinet is connected properly. <See chapter 6, [2].>
	Light from the LED sensor board is impeded.	Remove any obstacle that appears to be blocking or reflecting the light. (Remove any laminated signs or stickers attached above the control panel that appear to be impeding the light.)
	Sensor interference caused by another like machine.	Make sure that the interference prevention wire is attached properly. <See chapter 6.>
	Malfunction caused by ambient lighting.	Change product installation location if strong lighting is positioned near the monitor.
Operability of gun trigger is unsatisfactory.	Microswitch malfunction.	Replace microswitch. <See chapter 10.>
	Deformation of trigger; age deterioration of spring.	Replace part. <See chapter 10.>
	Gun screw has been tightened excessively.	Adjust to appropriate tightening.
The gun does not vibrate.	Solenoid malfunction.	Replace solenoid. <See chapter 10.>
	Fuse board's fuse blows out due to a temporary overload.	Remove the source of the overload. Then, replace the fuse. <See 15-2.> <Fuse: 250 V, 200 mA, 514-5143-200 & 250 V, 2 A, 514-5143-2000>
Fluorescent lamp does not illuminate.	Lamp life expired.	Replace lamp/glow lamp. <See chapter 13.>

CIRCUIT PROTECTOR

Functions due to the activation of bimetal. To restore the function, wait for approximately one minute or longer until the bimetal cools off. (Press the button.)

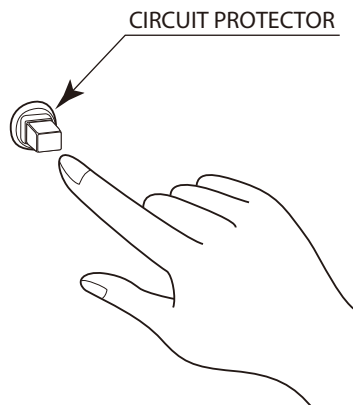

15-2 FUSE REPLACEMENT

1 Turn off the power.

2 Remove the six truss screws. Remove the rear lid of the rear cabinet.
 Make sure that the fuse's capacity matches the value specified on the sticker.

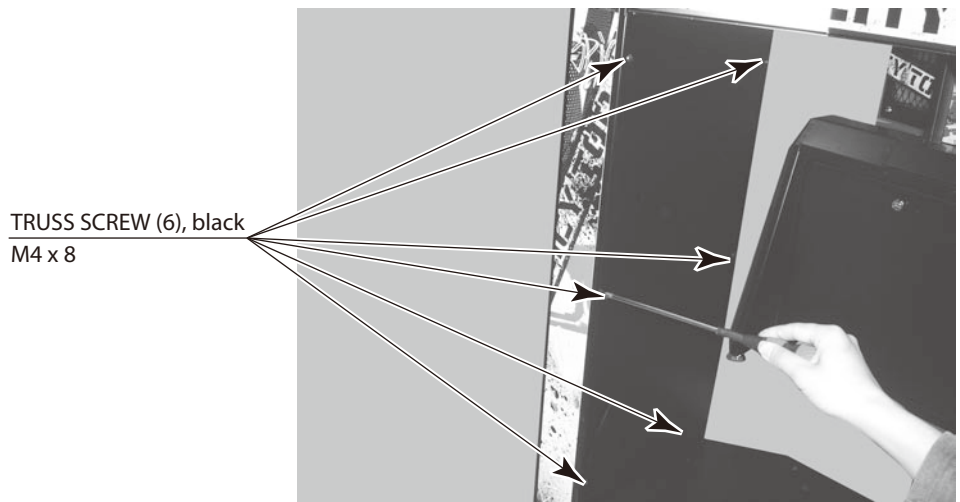

FIG. 15-2a

3 Replace the fuse.

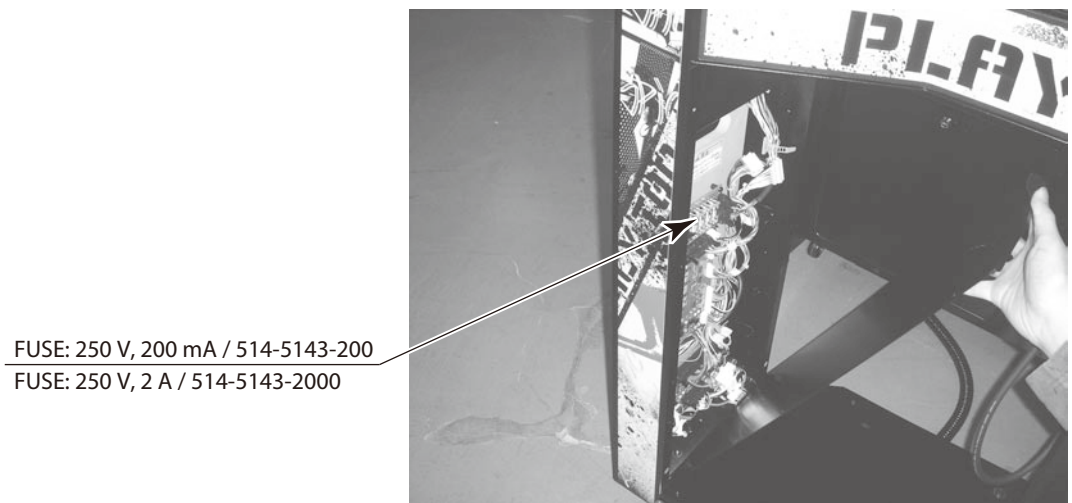

FIG. 15-2b

15-3 ERROR DISPLAY

WARNING

- If there is an error display, search out the cause immediately and take corrective action. If the product is operated while the error is ignored, there could be an accident. There could also be permanent damage to parts, etc.
- If an error is displayed, have the site maintenance personnel or other qualified individuals resolve it. If someone without specialized or technical knowledge attempts to rectify the problem, electric shock, short circuits or fire may result. If there is no site maintenance personnel or other qualified individuals available, turn the power off immediately, and contact your retailer or the office listed in this manual.
- If a problem not described in this manual and the LINDBERGH RED service manual occurs, or the resolution to a problem described in this manual is not effective, do not make further attempts to resolve the problem yourself. Immediately turn off the power and contact your retailer or the office listed in this manual. Any unguided attempts to solve such problems may lead to a serious accident.
- If countermeasures given in this manual have been taken and there are still no improvements, contact the point of purchase or the office indicated in these instructions.

Network Check during startup or when exiting Test Mode

When the communication method is set to “NETWORK” within NETWORK ASSIGNMENTS in the Test Mode, a check will be conducted when starting up the cabinets and when exiting Test Mode. If an error occurs, a screen such as the one below will be displayed.

```
CABINET ID      ... 1
NETWORK CHECK  ... NG
ERROR 6381
CHECK TIMEOUT
```

Press the TEST Button to enter Test Mode.

Verify that cables are properly connected, Test Mode settings are correct, and circuit boards are not damaged.

During Operation

If a network error occurs during a Player Battle, the screen below will be displayed, and a check will be conducted.

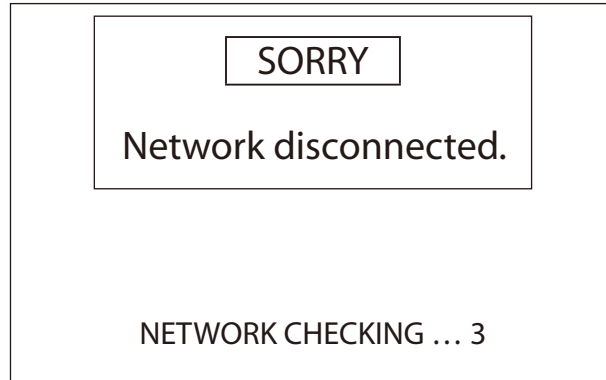

○ **When two players are in Versus Mode**

If an error occurs, a screen such as the one below will be displayed.
Press the TEST Button to enter Test Mode.

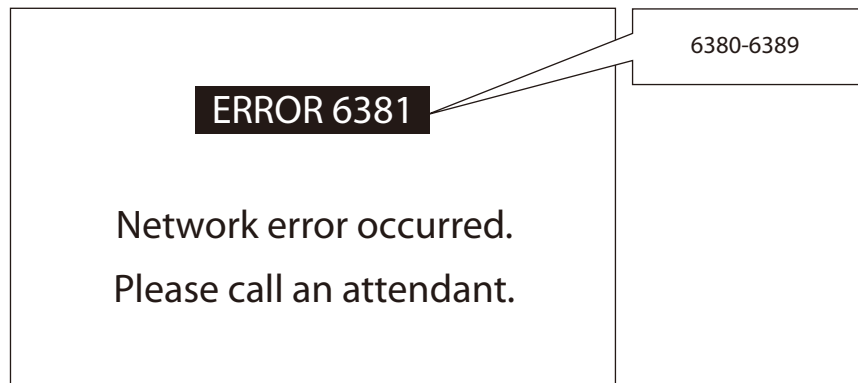

If there are no problems, the screen below will be displayed, and the round will be restarted.



○ **When two players are in Story Mode, or one is playing Story Mode and the other Versus Mode**

Whether or not an error occurs, a screen such as the one below will be displayed, and the game will return to the original mode.

If an error occurred, the players will no longer be matched up together.

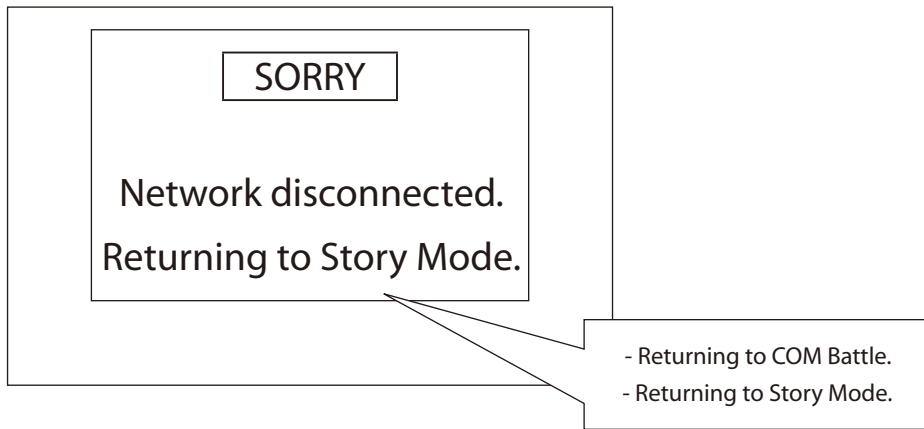

If an error occurred during the game, a check will be conducted during Attract Mode. If an error is still detected, a screen such as the one below will be displayed, and the cabinet will operate independently.

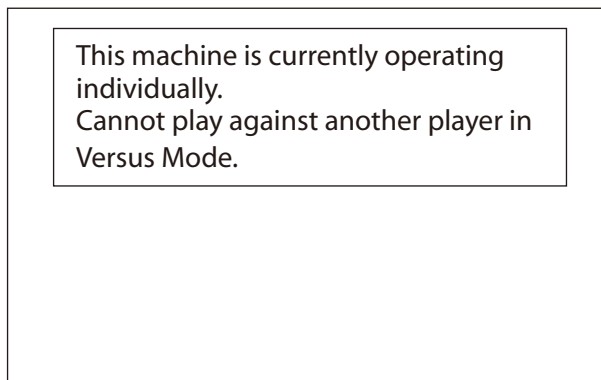

Verify that cables are properly connected, Test Mode settings are correct, and circuit boards are not damaged. When the error is resolved, the screen will no longer show.

Error Codes

ERROR 6380: UNKNOWN ERROR (Cause of error is not determined.)

Confirm points such as:

- Are the cables properly connected?
- Are Test Mode's settings correct?
- Are the circuit boards in good condition?

ERROR 6381: CHECK TIMEOUT (Network Check ran out of time.)

Confirm points such as:

- Are the cables properly connected?
- Is the other cabinet's power on?
- Is the other cabinet's communication setting set for "NETWORK"?
- Do both cabinets have different CABINET IDs?

ERROR 6383: DIFFERENT RESOLUTION (Network composed of cabinets with varying resolutions.)

- Communication cannot be established between a cabinet set at 640x480 (VGA) and another cabinet set at 1280x768 (WXGA).
- Operate using cabinets set with the same resolution.

ERROR 6389: PACKET LOST (Connection lost.)

Confirm points such as:

- Are the cables all making proper contact?
- Are hubs, etc. connected to the LAN?
- Are there devices that produce noise, such as strong magnetic charges, near the cabinet which may cause interference?

16 GAME BOARD

WARNING

- When working with the product, be sure to turn the power off. Working with the power on may cause an electric shock or short circuit.
- Be careful not to damage the wires. Damaged wires may cause an electric shock, short circuit or present a risk of fire.
- Do not expose the game board, etc. for any reason. Doing so may cause electric shock or malfunctioning.
- No connectors other than those connected on the game board when first delivered can be used by this product. Do not connect any other wires to any of the unused connectors. This may lead to the generation of heat, smoke or burn outs.
- When replacing or repairing the game board and then returning it to the cabinet, be sure to reconnect all the connectors correctly. Improper connection may cause electric shock, short circuit or fire.
- When connecting the connectors, be sure to attach them correctly. There is only one correct way in which they must be connected. Attempting to connect them incorrectly may cause damage to the pins on the connectors, and cause electric shock, short circuit or fire.

CAUTION

- In this product, setting changes are made using the Test Mode. The game board need not be operated. Use the game board, etc. as is with the same setting made at the time of shipment so as not to cause electric shock and malfunctioning.
- The chip parts on IC boards can be damaged by electrostatic discharge from the human body. Before handling an IC board, always neutralize any static charge in the body by touching a grounded metal surface.
- Be careful not to get fingers caught when removing doors or other parts.

IMPORTANT

- When exchanging the game board, place and post the damaged board in the new board's special packaging. If you do not have the packaging or it is damaged order one using the following product number/name <601-11691: CARTON BOX LBG>.
- When sending a board for repairs, do not dismantle the board in any way prior to sending it away. It may not be possible to meet your request if any parts are missing.
- Send a game board in for repair with the key chip still inserted.

16-1 REMOVING THE LINDBERGH RED

The LINDBERGH RED is mounted on the MAIN BD base (wooden board) inside the base box of the front cabinet. Remove the MAIN BD base, together with the LINDBERGH RED, from the base box.

1 Turn off the cabinet's power.

2 Unlock the front door with the master key. Remove the door. The LINDBERGH RED is the red sheet metal case found inside the door.

3 Remove the following connectors that are connected to the LINDBERGH RED. Hold the connector at its terminal and pull it straight it out. Be careful as not to pull it out at an angle.
The D-SUB connector and LAN cable have a fastening screw and a lock. After loosening the screw, remove the connector while opening the lock.

- D-SUB CONNECTOR
- LAN CABLE (Center of board / LAN terminal)
- JVS IO CABLE
- STEREO MINI PLUG CONNECTOR (Green / FRONT terminal)
- POWER CABLE CONNECTOR (18P, 24P) (1 of each)

CONNECTOR (total 6)



FIG. 16-1a

4 Remove the one thumbscrew which secures the MAIN BD base (wooden board).

THUMBSCREW (1)
M4 x 25, flat & spring washers used

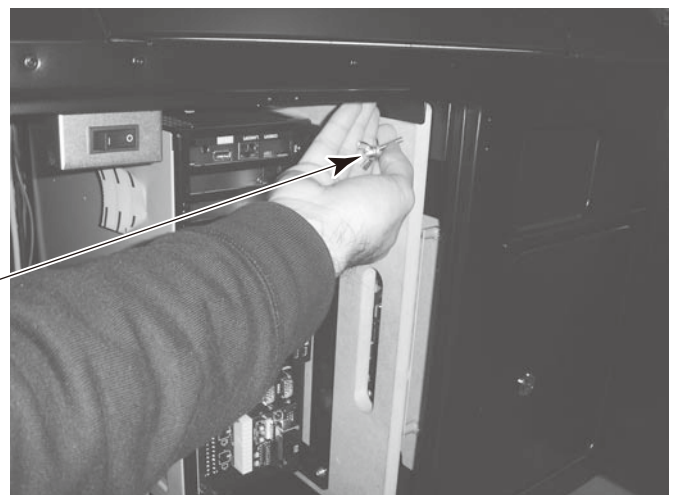

FIG. 16-1b

- 5** Taking care so not to catch the wiring, pull out the MAIN BD base together with the LINDBERGH RED.



FIG. 16-1c

- 6** Place the base on a level surface.

- 7** Remove the four screws which secure the LINDBERGH RED to the base.
When sending the LINDBERGH RED for repair, do not remove the key chip attached to the connector panel.

SCREW (4)
M4 x 16, w/flat & spring washers

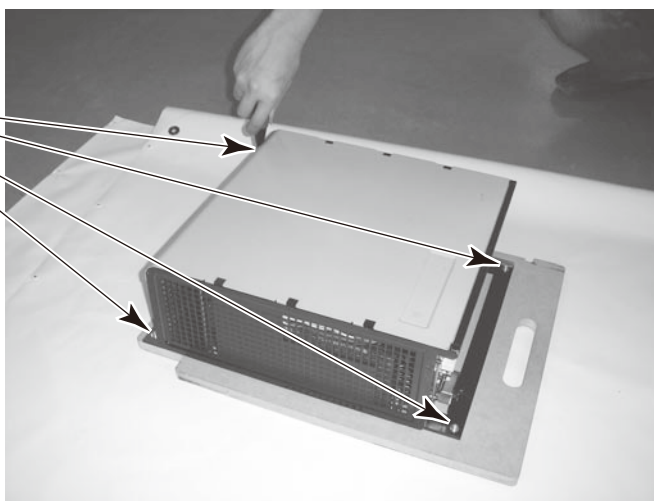

FIG. 16-1d

16-2 COMPOSITION OF THE GAME BOARD

STOP IMPORTANT

- The game board becomes the game board for this product once the key chip is inserted.
- The DIP SW (dip switches) on the board must be set as specified below. If set incorrectly for this product, an error will be displayed and the game will not run.

ASSY CASE LBJ L 512MB APA EXP (845-0002D-02)

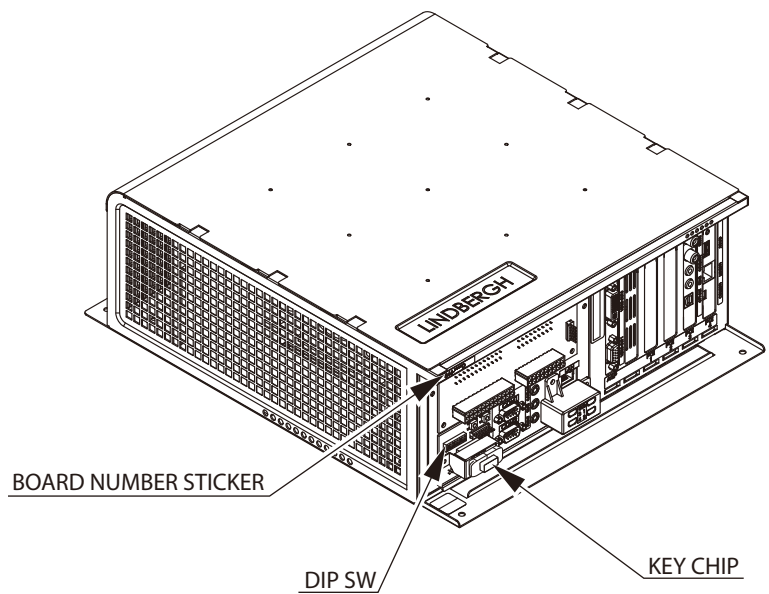

FIG. 16-2a

DIP SW Setting

Use this product with the DIP SW settings shown in the figure below.

NOTE: It is not possible to conduct competitive play with two machines if the cabinets have different DIP SW settings.

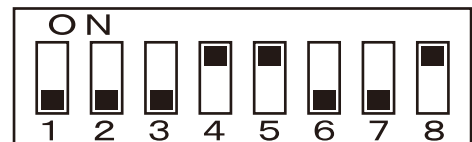

FIG. 16-2b For 1280 x 768 Resolution

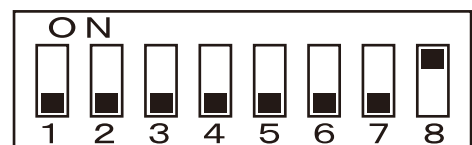
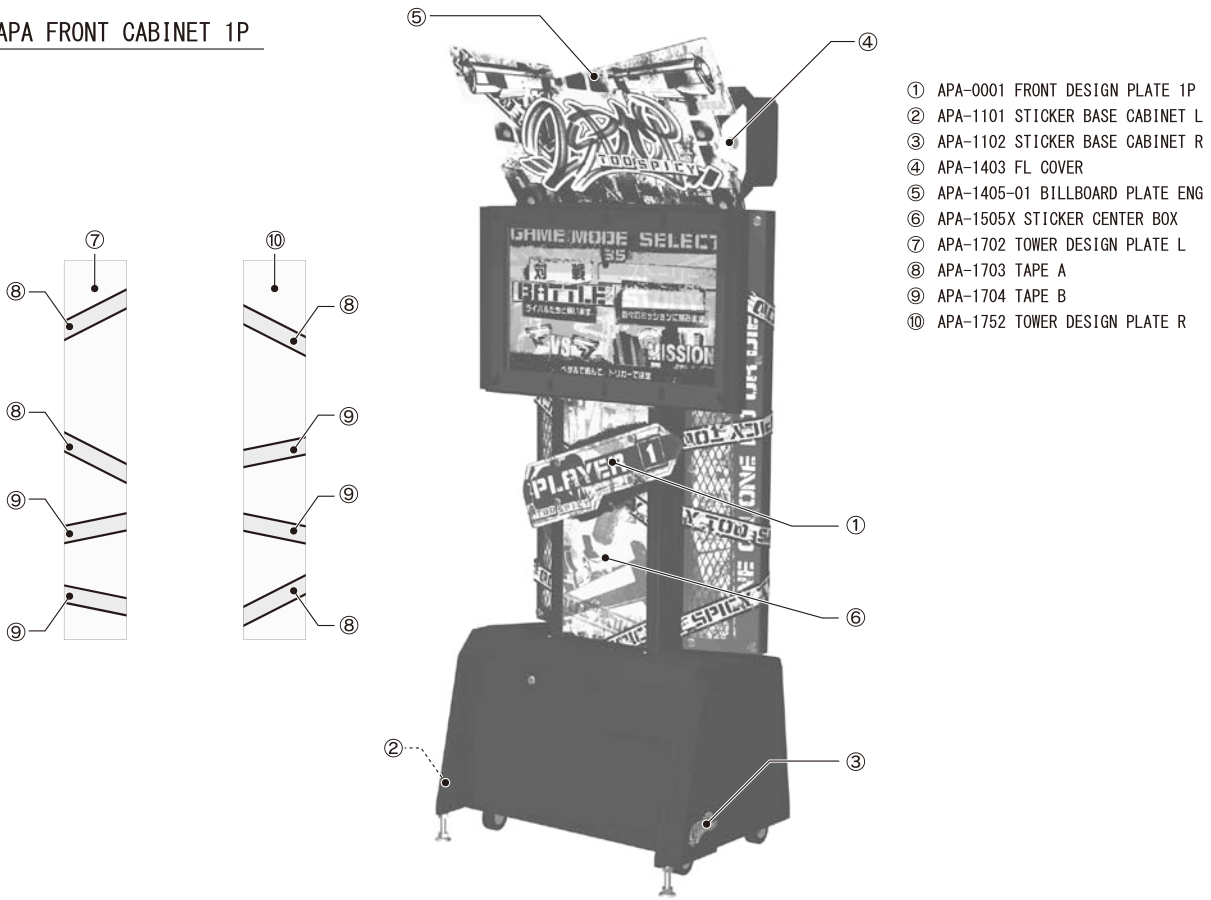

FIG. 16-2c For 640 x 480 Resolution

17 DESIGN-RELATED PARTS

For the warning display stickers, refer to Section 1.

APA FRONT CABINET 1P



- ① APA-0001 FRONT DESIGN PLATE 1P
- ② APA-1101 STICKER BASE CABINET L
- ③ APA-1102 STICKER BASE CABINET R
- ④ APA-1403 FL COVER
- ⑤ APA-1405-01 BILLBOARD PLATE ENG
- ⑥ APA-1505X STICKER CENTER BOX
- ⑦ APA-1702 TOWER DESIGN PLATE L
- ⑧ APA-1703 TAPE A
- ⑨ APA-1704 TAPE B
- ⑩ APA-1752 TOWER DESIGN PLATE R

FIG. 17a

APA REAR CABINET 1P

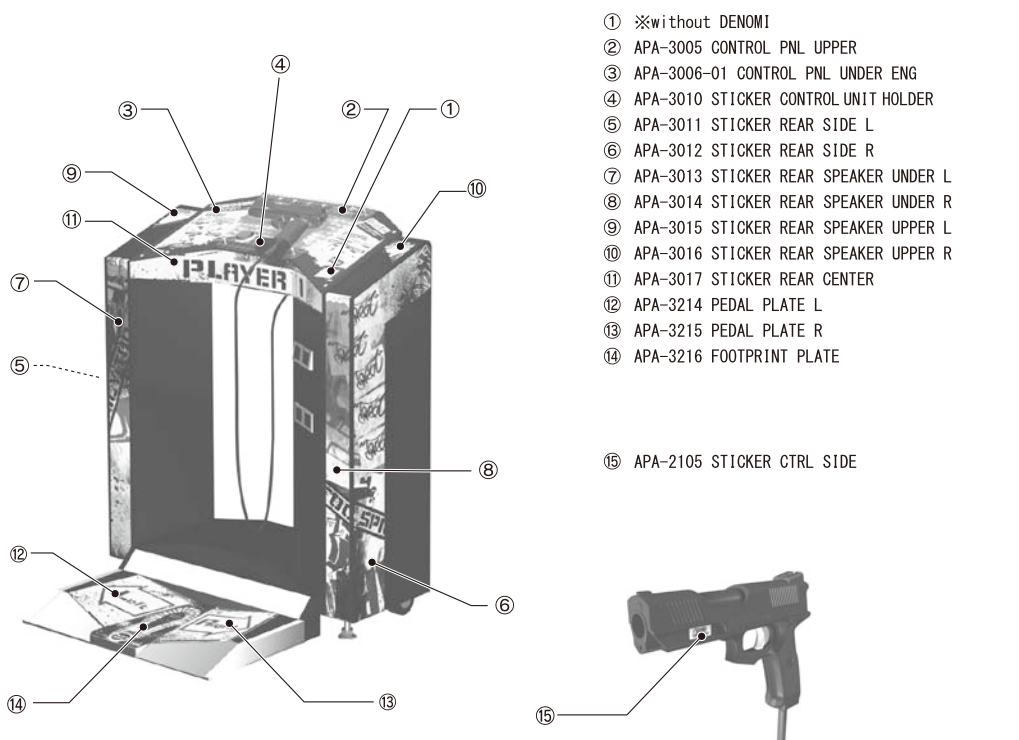

- ① ※without DENOMI
- ② APA-3005 CONTROL PNL UPPER
- ③ APA-3006-01 CONTROL PNL UNDER ENG
- ④ APA-3010 STICKER CONTROL UNIT HOLDER
- ⑤ APA-3011 STICKER REAR SIDE L
- ⑥ APA-3012 STICKER REAR SIDE R
- ⑦ APA-3013 STICKER REAR SPEAKER UNDER L
- ⑧ APA-3014 STICKER REAR SPEAKER UNDER R
- ⑨ APA-3015 STICKER REAR SPEAKER UPPER L
- ⑩ APA-3016 STICKER REAR SPEAKER UPPER R
- ⑪ APA-3017 STICKER REAR CENTER
- ⑫ APA-3214 PEDAL PLATE L
- ⑬ APA-3215 PEDAL PLATE R
- ⑭ APA-3216 FOOTPRINT PLATE
- ⑮ APA-2105 STICKER CTRL SIDE

FIG. 17b

18 PARTS LIST

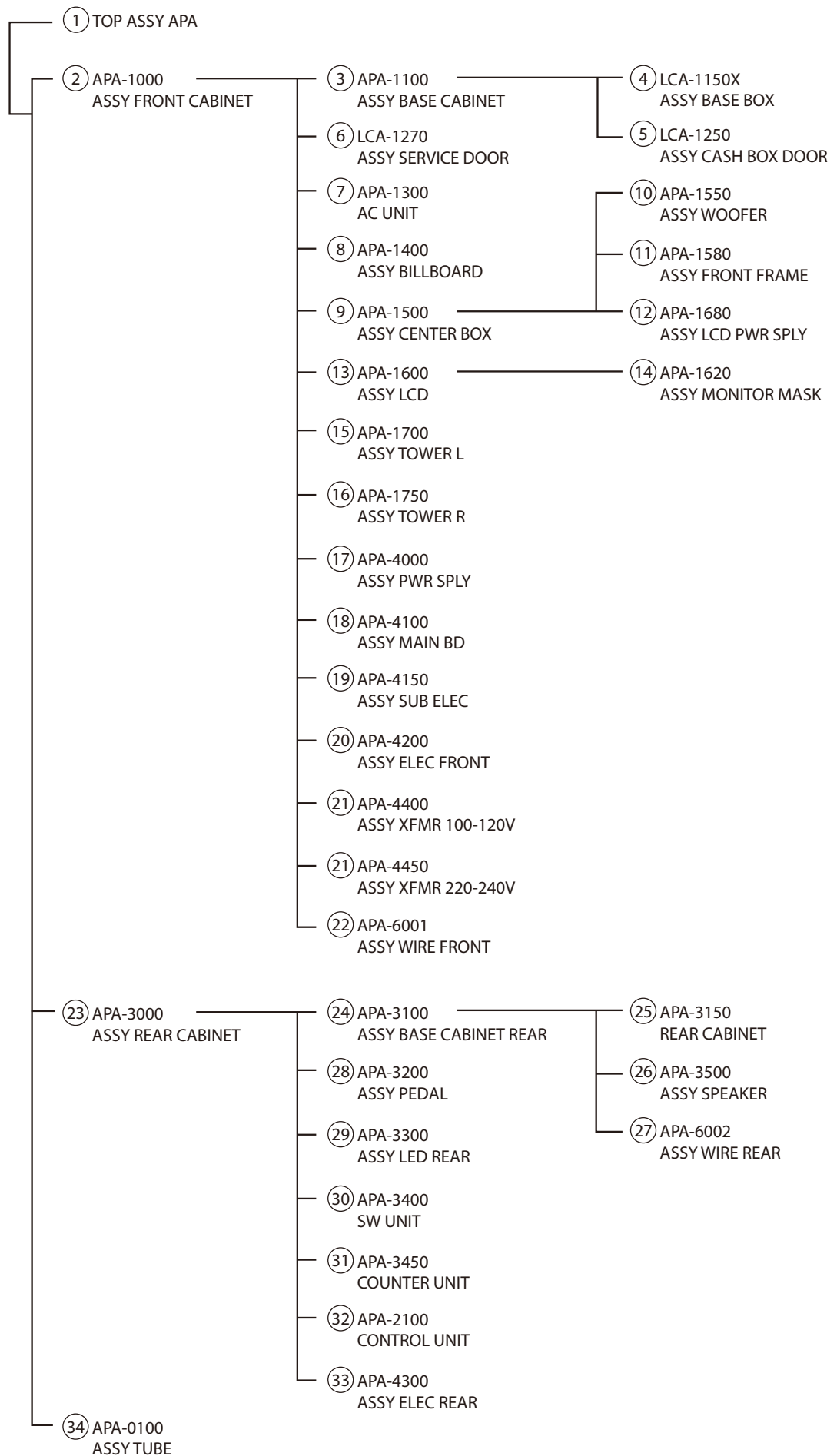

1 TOP ASSY APA

(D-1/2)

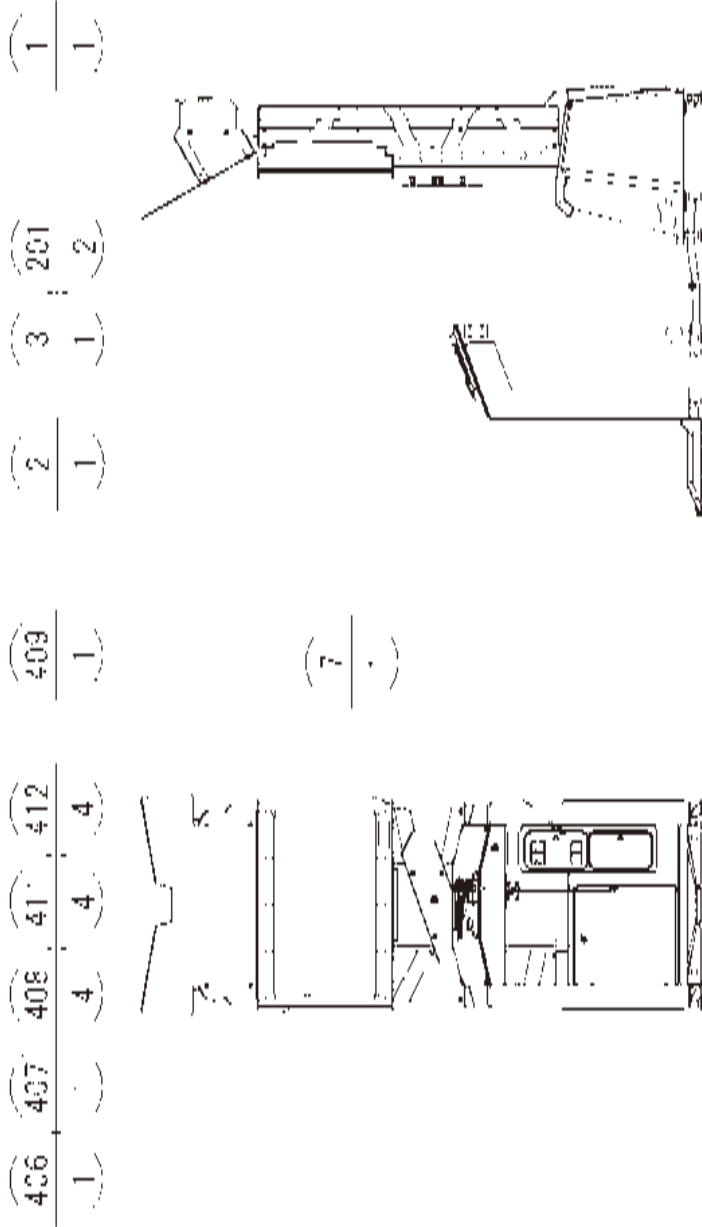

NOTE: 1P side (406), 2P side (407), (409) attachment.

"A"

"B"

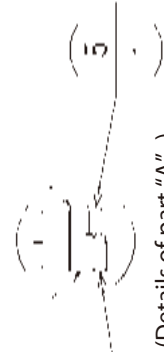
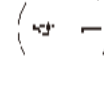
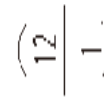
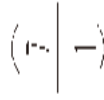

(Details of part "B")

(Details of part "A")

1 TOP ASSY APA

(D-2/2)

ITEM NO.	PART NO.	DESCRIPTION	NOTE
1	APA-1000	ASSY FRONT CABINET	
2	APA-3000	ASSY REAR CABINET	
3	APA-0100	ASSY TUBE	
8	421-8479-01	STICKER INSTR SUNLIGHT ENG	
9	SGM-3811	POLTHN COV 850×900×1700	
10	SGM-1798	POLY COVER 760×380×1000	
201	000-P00412-W	M SCR PH W/FS M4×12	
202	000-T00430-0B	M SCR TH BLK M4×30	
401	220-5793-2-A001	KEY MASTER A001	
402	SGM-4111Y	KEY BAG	
403	420-7031-01	OWNERS MANUAL APA ENG	
404	420-7032-01	SERVICE MANUAL LBJ ENG	
406	APA-0001	FRONT DESIGN PLATE 1P	
407	APA-0002	FRONT DESIGN PLATE 2P	
408	APA-0003	PLATE LEG	
409	APA-0004	STICKER 1P2P	
411	FAS-290045	HEX SKT LH CAP SCR STN M4×6	
412	280-6686-01	SP WSHR 4.5×16×4	
413	600-7269-0500	ASSY LAN CABLE 0500CM	
414	600-6729-01	AC CABLE CONNECT TYPE 15A W/E	<Taiwan>
	600-6619-02	AC CABLE CONNECT TYPE FOR UK	<Singapore, Malaysia>
	600-6619-01	AC CABLE CONNECT TYPE FOR EXP	<Philippines, Korea, Indonesia, Hong Kong, Australia>
415	443-50002D-02	STICKER 845-0002D-02	
416	509-5080	SW MICRO TYPE	
417	310-5029-D20	SUMITUBE F D 20MM	
418	514-5143-200	FUSE S.B 200MA250V HBC CE ROHS	
419	514-5143-2000	FUSE S.B2000MA250V HBC CE ROHS	
420	605-0094-01	ASSY WIRE DVD FOR LINDBERGH L	
/	421-6690-06	STICKER 110V	<Taiwan>
/	421-6690-04	STICKER 230V	<Singapore>
/	421-6690-03	STICKER 220V(80556)	<Philippines, Korea, Indonesia, Hong Kong>
/	421-6690-05	STICKER 240V	<Malaysia, Australia>

2 ASSY FRONT CABINET (APA-1000)

(D-1/2)

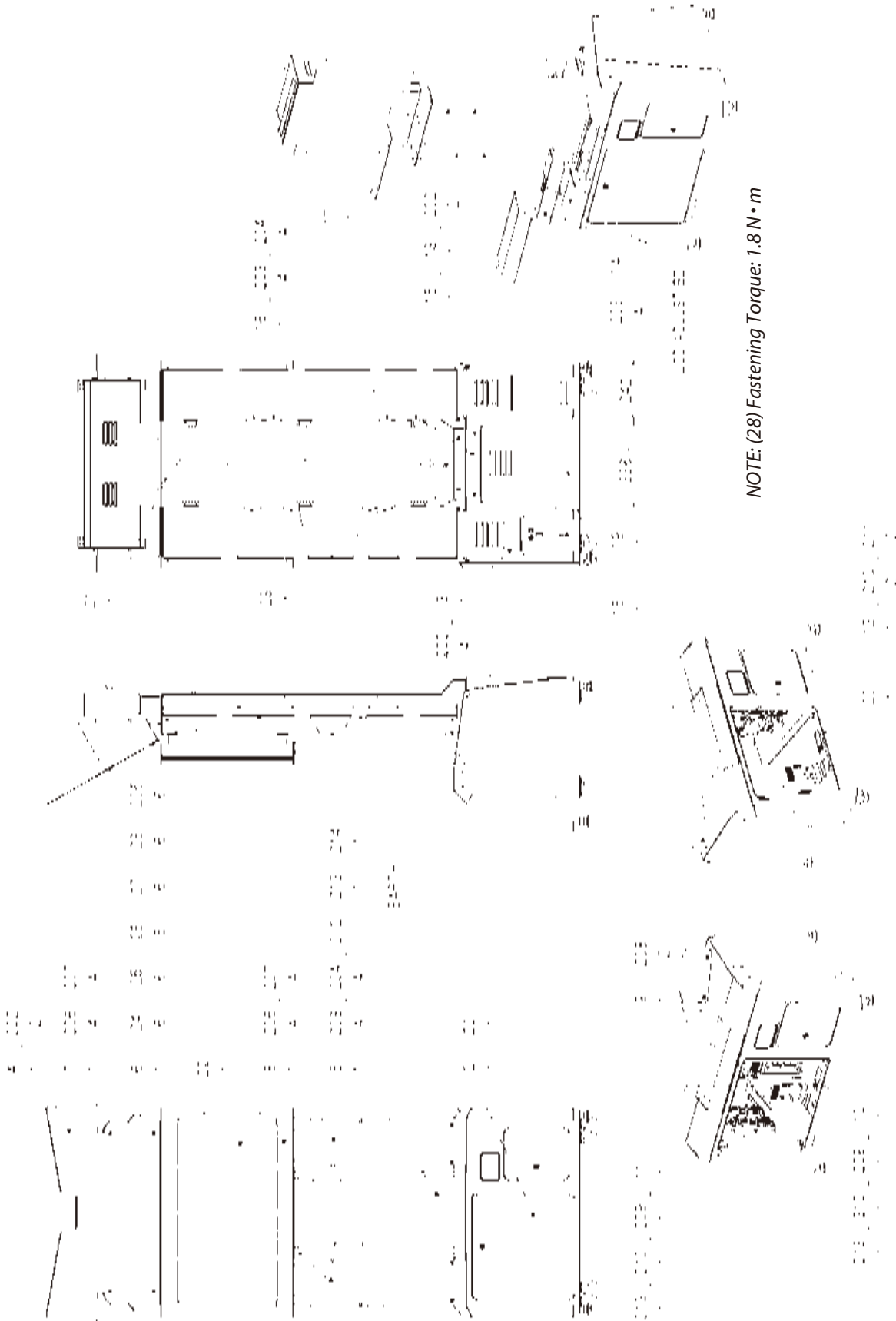

② ASSY FRONT CABINET (APA-1000)

(D-2/2)

ITEM NO.	PART NO.	DESCRIPTION	NOTE
1	APA-1100	ASSY BASE CABINET	
2	LCA-1270	ASSY SERVICE DOOR	
3	APA-1300	AC UNIT	
4	APA-1400	ASSY BILLBOARD	
5	APA-1500	ASSY CENTER BOX	
6	APA-1600	ASSY LCD	
7	APA-1700	ASSY TOWER L	
8	APA-1750	ASSY TOWER R	
9	APA-4000	ASSY PWR SPLY	
10	APA-4100	ASSY MAIN BD	
11	APA-4150	ASSY SUB ELEC	
12	APA-4200	ASSY ELEC FRONT	
13	VTF-1006	FRONT COVER SPONGE	
14	APA-1001	FRONT COVER BRKT	
15	APA-1002	FRONT COVER	
16	APA-1003	TOWER HOLDER REAR	
17	APA-1004	CUSHION CENTER	
18	421-11416	STICKER CAUTION FORK	
20	440-WS0165-EG	STICKER W BD POWER OFF S ENG	
21	440-WS0164-EG	STICKER W FALL ENG	
22	440-CS0186-EG	STICKER C EPILEPSY 40 ENG	
23	440-WS0300-EG	STICKER W POWER OFF & HI TEMP ENG	
24	123-5123-91	STUD BOLT M6 FOR LCD	
25	280-5113	COLLAR FOR TV	
26	280-5114	SPACER 6.4-25×2	
27	253-5569	BUSH FOR LCD	
28	253-5570	CAP FOR LCD	
101	280-5277	CORD CLAMP 18	
102	280-5275-SR10	CORD CLAMP SR10	
103	280-6676	CORD CLAMP TL-25A TTK	
201	000-T00430-0B	M SCR TH BLK M4×30	
202	000-T00408-0B	M SCR TH BLK M4×8	
203	030-000820-SB	HEX BLT W/S BLK M8×20	
204	068-852216-0B	FLT WSHR BLK 8.5-22×1.6	
205	050-F00600	FLG NUT M6	
206	030-000616-S	HEX BLT W/S M6×16	
207	068-652016	FLT WSHR 6.5-20×1.6	
208	000-P00412-W	M SCR PH W/FS M4×12	
209	032-000425	WING BLT M4×25	
210	068-441616	FLT WSHR 4.4-16×1.6	
211	000-P00425-S	M SCR PH W/S M4×25	
213	060-S00400	SPR WSHR M4	
215	FAS-000006	M SCR PH PORICURVO M3×10	
216	068-330808-PN	FLT WSHR PLASTIC 3.3-8×0.8	
301	APA-6001-01	ASSY WIRE FRONT EXP	
302	APA-60005	WH DC24V FOR LCD	
303	600-7360-0400	WH LBG PWR 24P P TO P 0400MM	
304	600-7361-0400	WH LBG PWR 18P P TO P 0400MM	
306	APA-60008	WH DC5V FRONT CABINET	
/	APA-4400	ASSY XFMR 100V-120V	<Taiwan>
/	APA-4450	ASSY XFMR 220V-240V	<Singapore, Philippines, Malaysia, Korea, Indonesia, Hong Kong, Australia>

3 ASSY BASE CABINET (APA-1100)

(D-1/2)

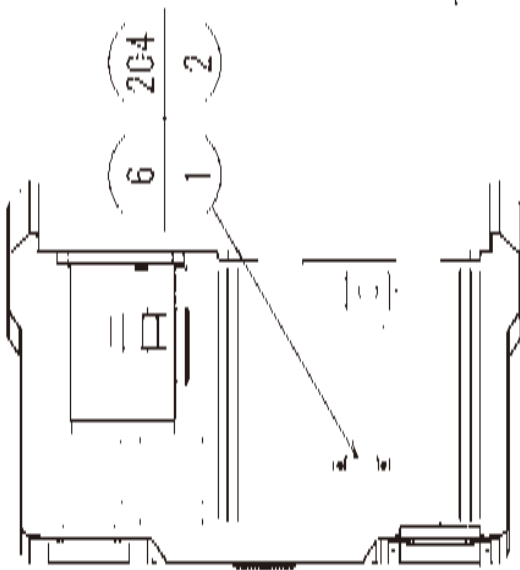
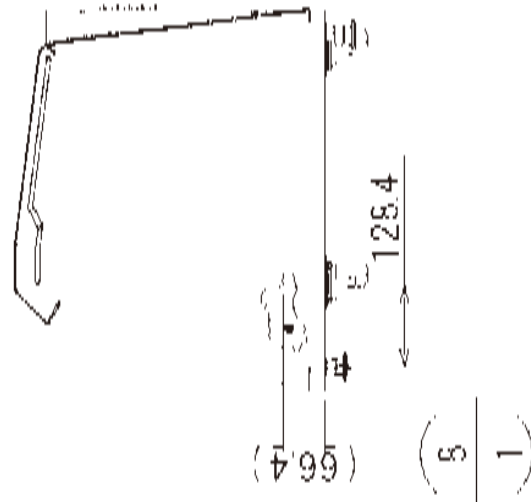
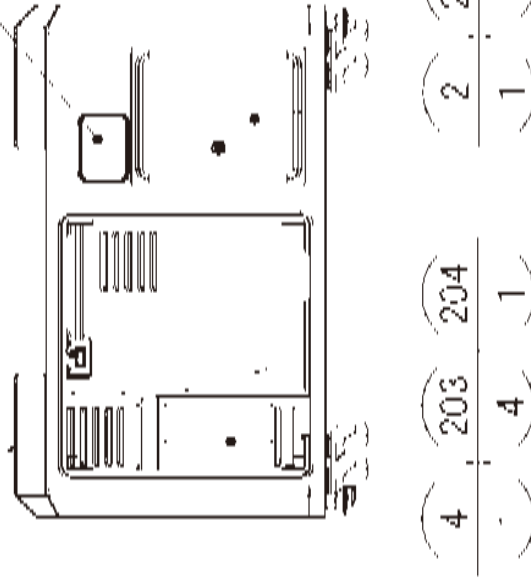
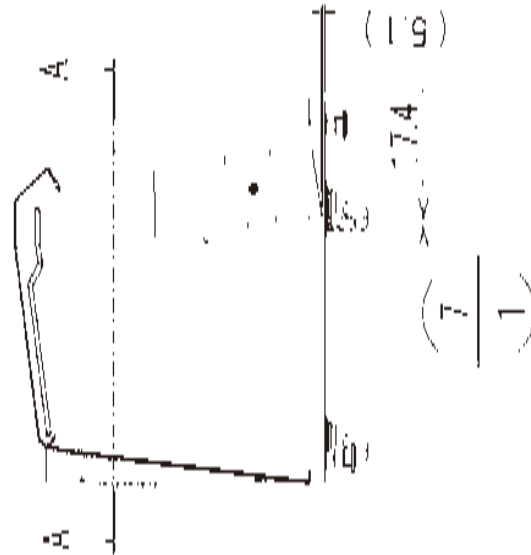

Diagram of cross-section A-A



③ ASSY BASE CABINET (APA-1100)

(D-2/2)

ITEM NO.	PART NO.	DESCRIPTION	NOTE
1	LCA-1150X	ASSY BASE BOX	
2	LCA-1250	ASSY CASH BOX DOOR	
3	VTF-0101	REJECT LID	
4	LCA-1102	COM BRKT	
5	LCA-1104	EX SW HOLDER	
6	LCA-1105	ELEC HOLDER	
7	APA-1101	STICKER BASE CABINET L	
8	APA-1102	STICKER BASE CABINET R	
101	509-6102-H-B	SW ROCKER J8 H-B AJ8201BF	
201	000-F00308	M SCR FH M3×8	
202	050-F00400	FLG NUT M4	
203	000-T00408-0B	M SCR TH BLK M4×8	
204	000-P00408-W	M SCR PH W/FS M4×8	

④ ASSY BASE BOX (LCA-1150X)

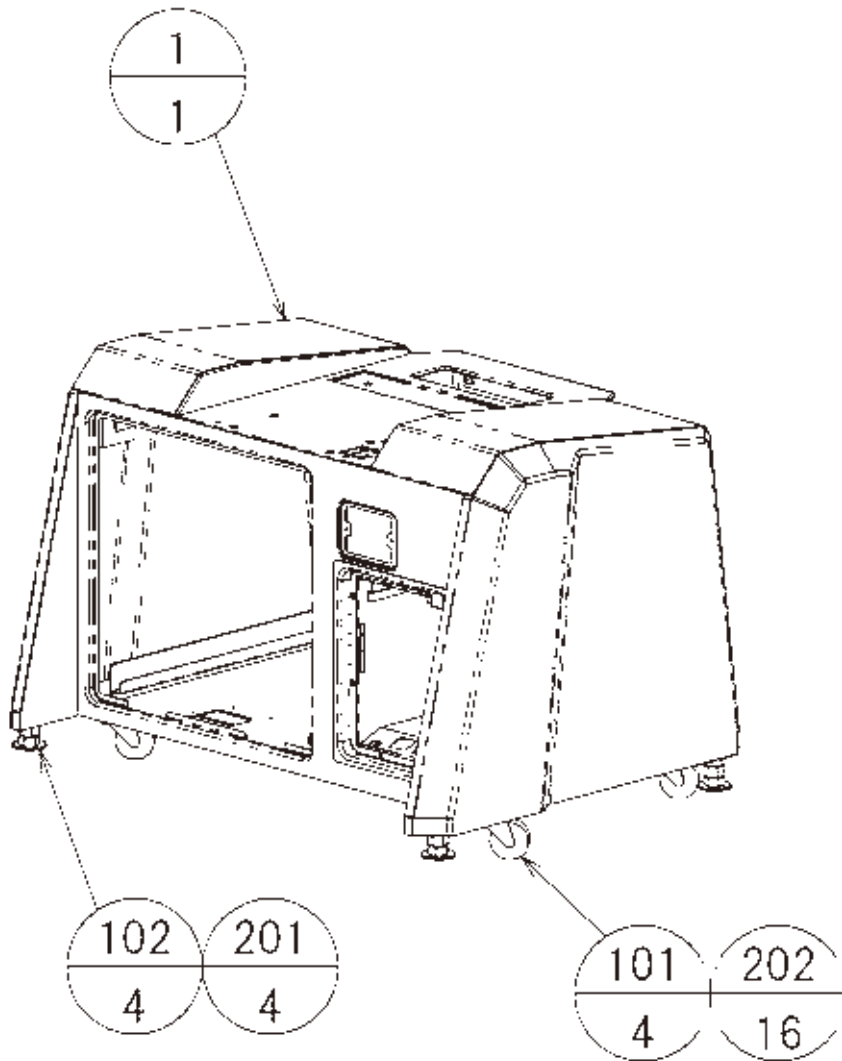

ITEM NO.	PART NO.	DESCRIPTION	NOTE
1	LCA-1151X	BASE BOX	
101	601-10905	CASTER D51H66 FREE ST	
102	601-5699X	LEG ADJUSTER BOLT M16×75	
201	050-H01600	HEX NUT M16	
202	030-000620-S	HEX BLT W/S M6×20	

⑤ ASSY CASH BOX DOOR (LCA-1250)

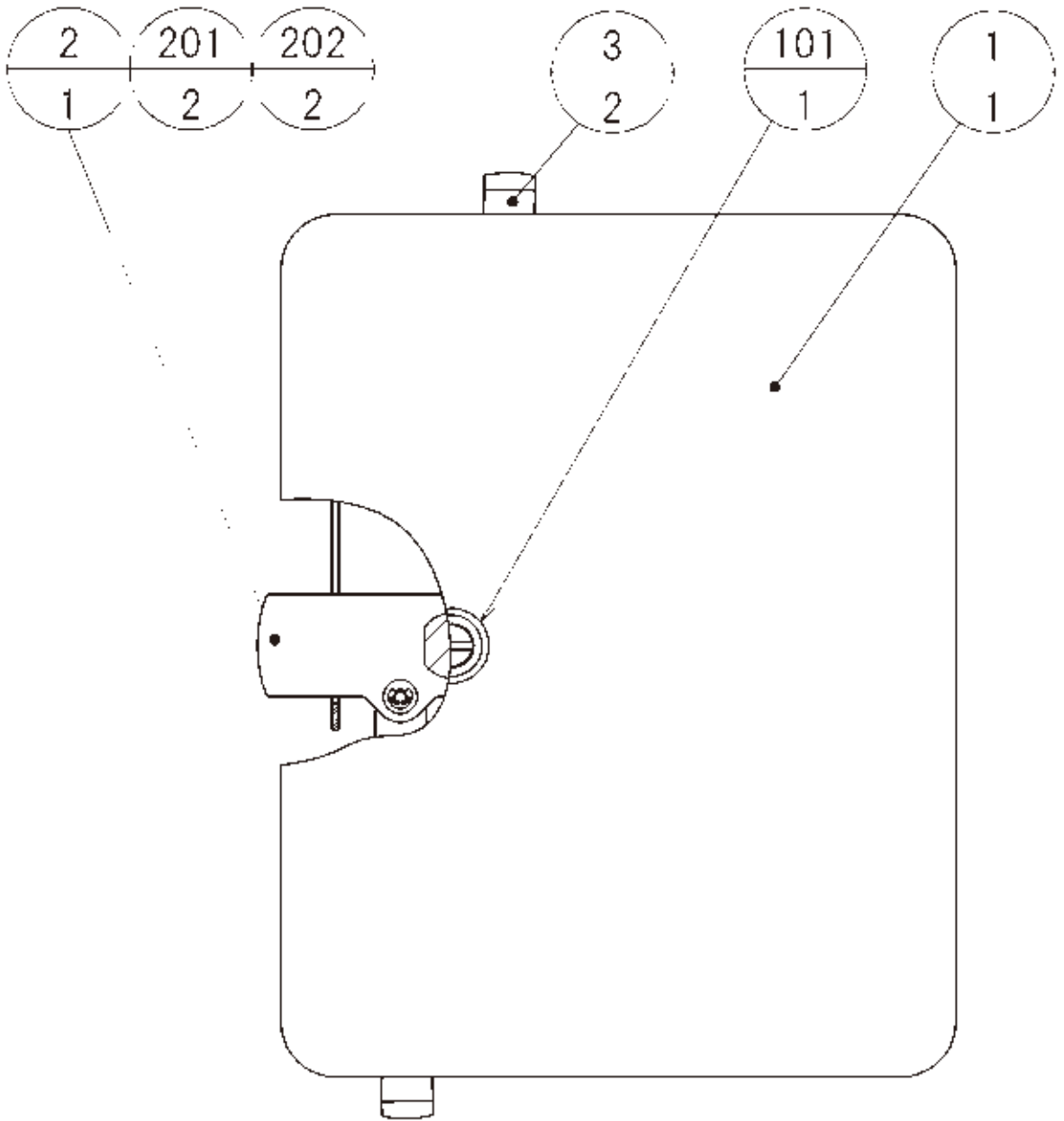

ITEM NO.	PART NO.	DESCRIPTION	NOTE
1	OLS-1651	CASH BOX DOOR	
2	HOT-1203X	CENTER TNG	
3	HOT-1204X	SIDE TNG	
101	220-5794	CLY LOCK W/KEYS	
201	065-E00300	E RING 3MM	
202	060-F00400	FLT WSHR M4	

6 ASSY SERVICE DOOR (LCA-1270)

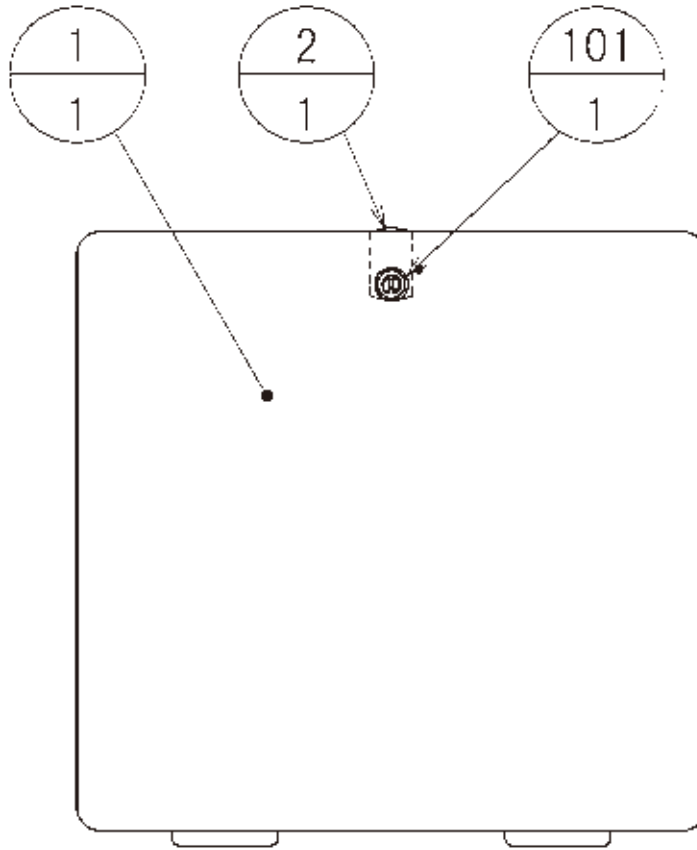

ITEM NO.	PART NO.	DESCRIPTION	NOTE
1	LCA-1271	SERVICE DOOR	
2	DP-1167	TNG LKG	
101	220-5793-1-A001	CLY LOCK MASTER W/O KEY A001	

7 AC UNIT (APA-1300)



ITEM NO.	PART NO.	DESCRIPTION	NOTE
1	APA-1301	AC BRKT	
2	421-7468-02	STICKER C.P W/PIC	
3	421-8202	STICKER EARTH MARK	
101	509-6102-V-B	SW ROCKER J8 V-B AJ8202BF	
102	214-0202	AC INLET PANEL TYPE	
104	512-5046-91-08	C.P 8A CE UL NRW10-8A-TK2421	<Taiwan>
	512-5046-91-05	C.P 5A CE UL NRW10-5A-TK2421	<Singapore, Philippines, Malaysia, Korea, Indonesia, Hong Kong, Australia>
106	270-5115	NOISE FILTER 15A GT-215J	
107	280-0417	TERMINAL BINDING POST BLACK	<Taiwan>
		Not Used	<Others>
108	450-5126	MAGNET CONTACT S-NIOCX	<Taiwan>
	450-5134	MAGNET CONTACT S-NIOCX AC 230V	<Singapore, Malaysia, Indonesia, Hong Kong, Australia>
	450-5133	MAGNET CONTACT S-NIOCX AC 200V	<Philippines, Korea>
109	280-5277	CORD CLAMP 18	
110	310-5029-H20	SUMITUBE F H 20MM	
111	601-0460	PLASTIC TIE BELT 100 MM	
201	000-P00408-WB	M SCR PH W/FS BLK M4×8	
202	000-P00416-WB	M SCR PH W/FS BLK M4×16	
203	050-H00400	HEX NUT M4	
204	060-S00400	SPR WSHR M4	
205	060-F00400	FLT WSHR M4	
301	LCA-60001	WH AC UNIT INLET	
302	LCA-60004	WH AC UNIT NOISE FILTER OUT	
303	LCA-60025	WH AC UNIT SW	
304	APA-60051	WH EARTH AC UNIT	

8 ASSY BILLBOARD (APA-1400)

(D-1/2)

(20) (202)

(2) (1)

(7) (1)

(8) (1)

(20) (6) (2)

(204) (203) (2)

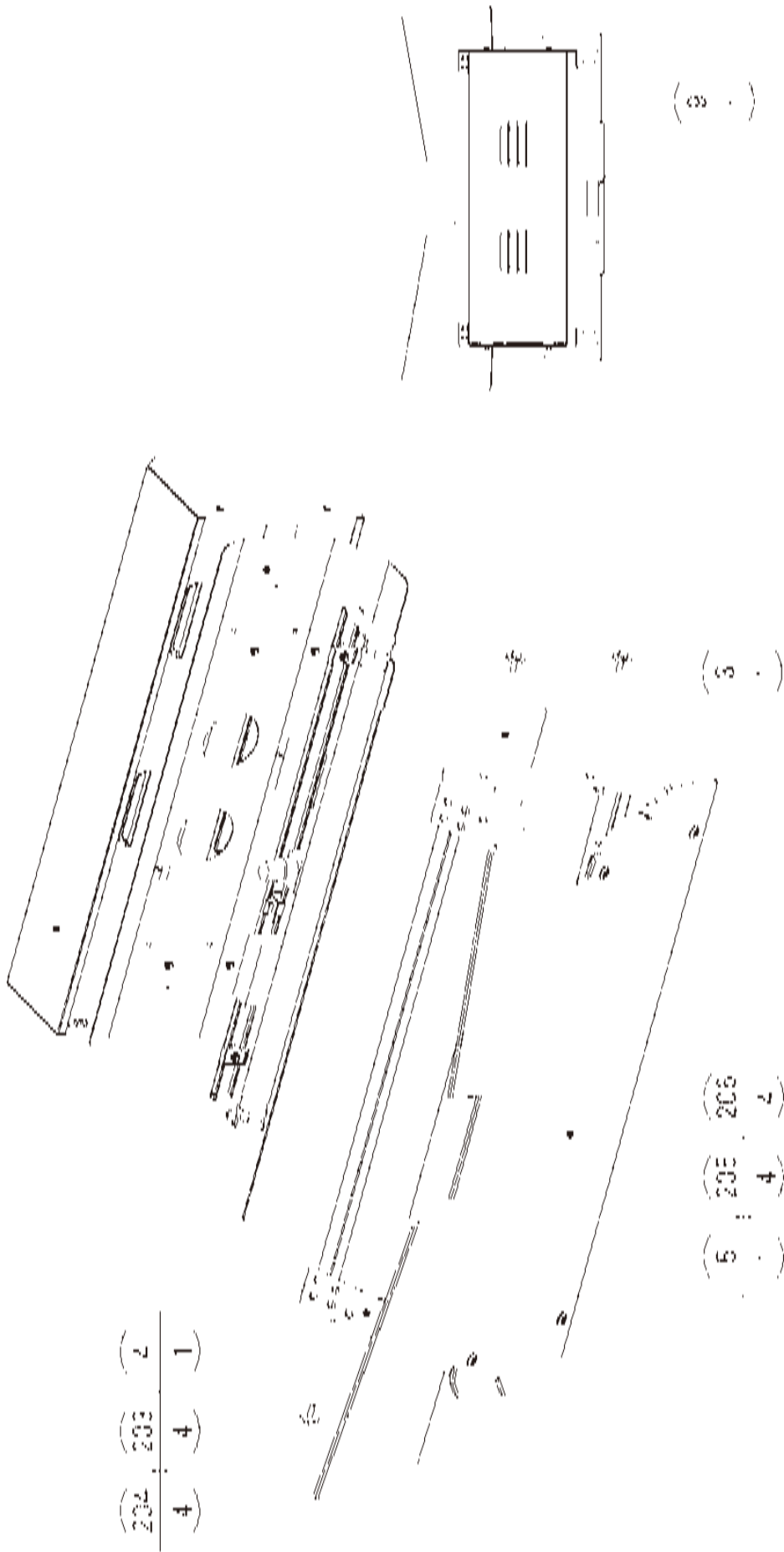

8 ASSY BILLBOARD (APA-1400)**(D-2/2)**

ITEM NO.	PART NO.	DESCRIPTION	NOTE
1	APA-1401	BILLBOARD BOX	
2	APA-1402	REF BOARD	
3	APA-1403	FL COVER	
4	APA-1404	PLATE HOLDER	
5	APA-1405-01	BILLBOARD PLATE ENG	
6	253-5457	FL HOLDER	
7	440-WS0300-EG	STICKER W POWER OFF & HI TEMP EG	
8	421-7501-17	STICKER FL 20W	
101	390-6822-20EX	ASSY FL20W EX W/CONN HIGH	
102	280-5277	CORD CLAMP 18	
201	000-P00430-W	M SCR PH W/FS M4×30	
202	000-T00408-0C	M SCR TH CRM M4×8	
203	030-000616-SB	HEX BLT W/S BLK M6×16	
204	068-652016-0B	FLT WSHR BLK 6.5-20×1.6	
205	FAS-290045	HEX SKT LH CAP SCR STN M4×6	
206	280-6686-01	SP WSHR 4.5×16×4	
301	APA-60002	WH AC100V BILLBOARD	

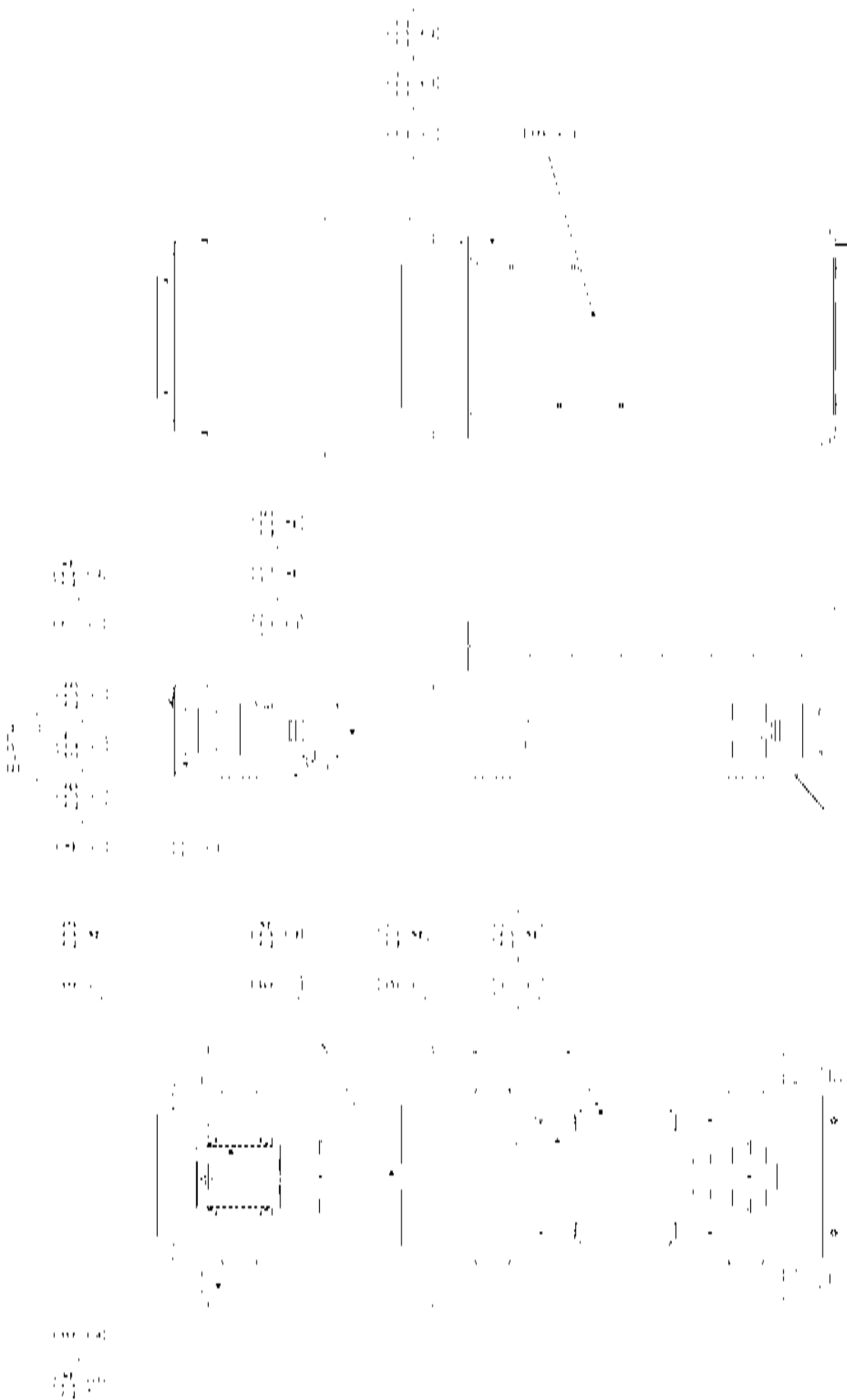

9 ASSY CENTER BOX (APA-1500)

(D-2/2)

ITEM NO.	PART NO.	DESCRIPTION	NOTE
1	APA-1550	ASSY WOOFER	
2	APA-1580	ASSY FRONT FRAME	
3	APA-1680	ASSY LCD PWR SPLY	
4	APA-1501	CENTER BOX	
5	APA-1502	REAR FRAME	
6	APA-1503	REAR LID	
7	APA-1504	BILLBOARD HOLDER	
8	APA-1505X	STICKER CENTER BOX	
9	APA-1506	SHADE	
10	253-5457	FL HOLDER	
11	421-7501-18	STICKER FL32W	
101	390-6822-32EX	ASSY FL32W EX W/CONN HIGH	
201	000-P00408-W	M SCR PH W/FS M4×8	
202	000-F00406	M SCR FH M4×6	
203	050-F00300	FLG NUT M3	
204	000-T00408-0B	M SCR TH BLK M4×8	
205	050-F00400	FLG NUT M4	
206	050-H00400	HEX NUT M4	
207	060-S00400	SPR WSHR M4	
208	060-F00400	FLT WSHR M4	
301	APA-60054	WH EARTH CENTER BOX	

10 ASSY WOOFER (APA-1550)

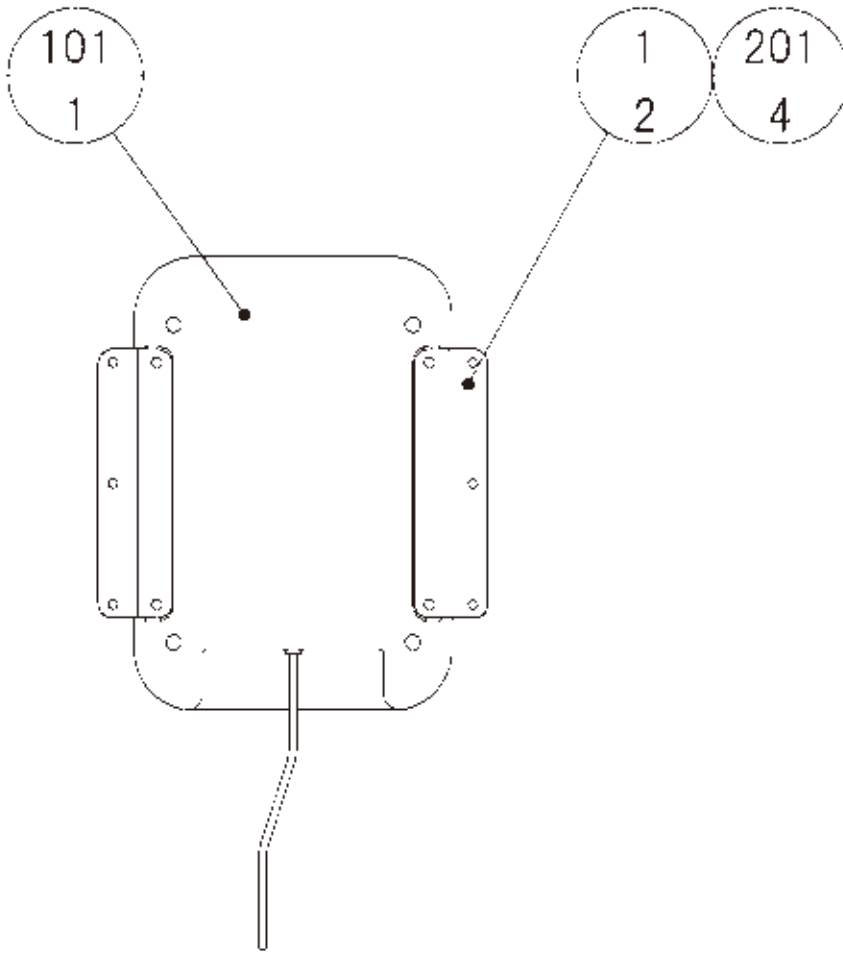

ITEM NO.	PART NO.	DESCRIPTION	NOTE
1	APA-1551	WOOFER BRKT	
101	130-5218-01	SUB WOOFER 4OHM 40W YL	
201	012-T00412	TAP SCR #2 TH 4×12	

11 ASSY FRONT FRAME (APA-1580)

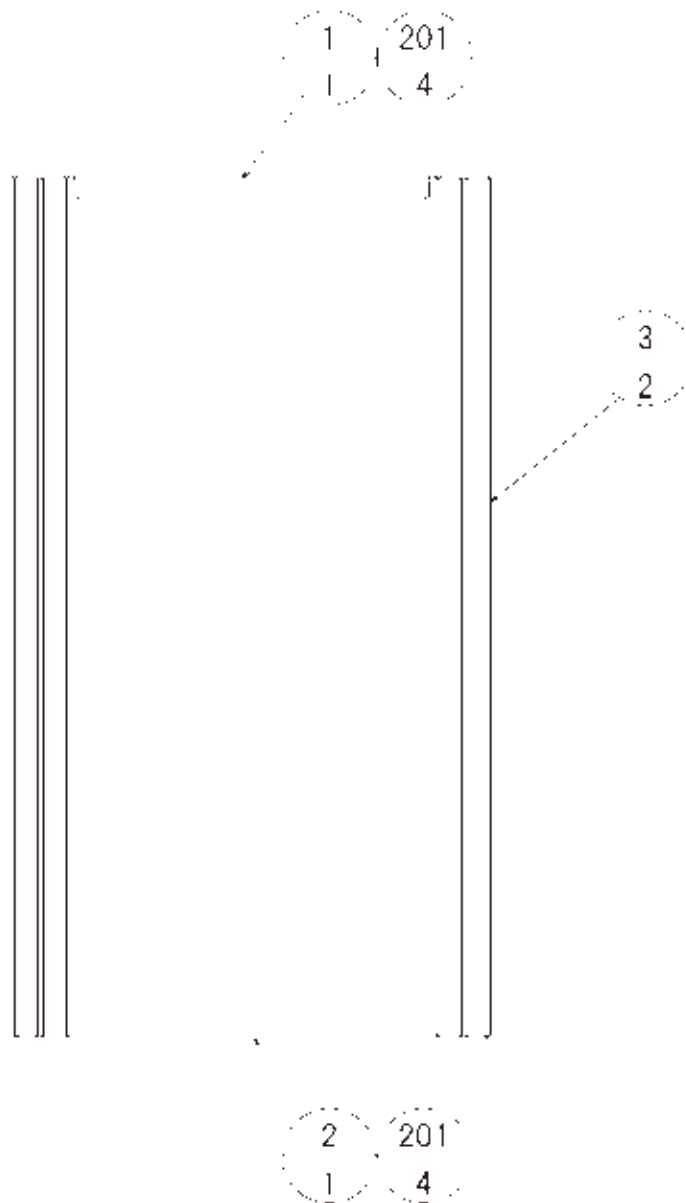

ITEM NO.	PART NO.	DESCRIPTION	NOTE
1	APA-1581	FF UPPER BRKT	
2	APA-1582	FF LOWER BRKT	
3	APA-1583	FF SIDE COVER	
201	010-F00310-0B	S-TITE SCR FH BLK M3×10	

12 ASSY LCD PWR SPLY (APA-1680)

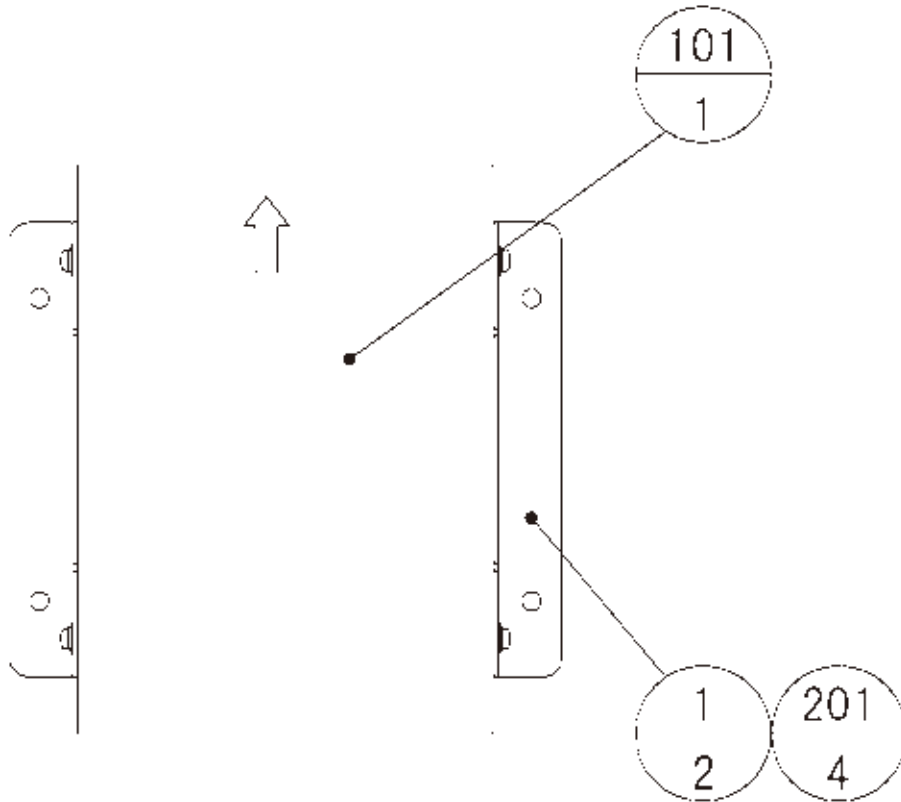

ITEM NO.	PART NO.	DESCRIPTION	NOTE
1	APA-1681	SW REG BRKT	
101	400-5461-01	SW REGU FOR LCD 32TYPE	
201	000-P00306-W	M SCR PH W/FS M3×6	

13 ASSY LCD (APA-1600)

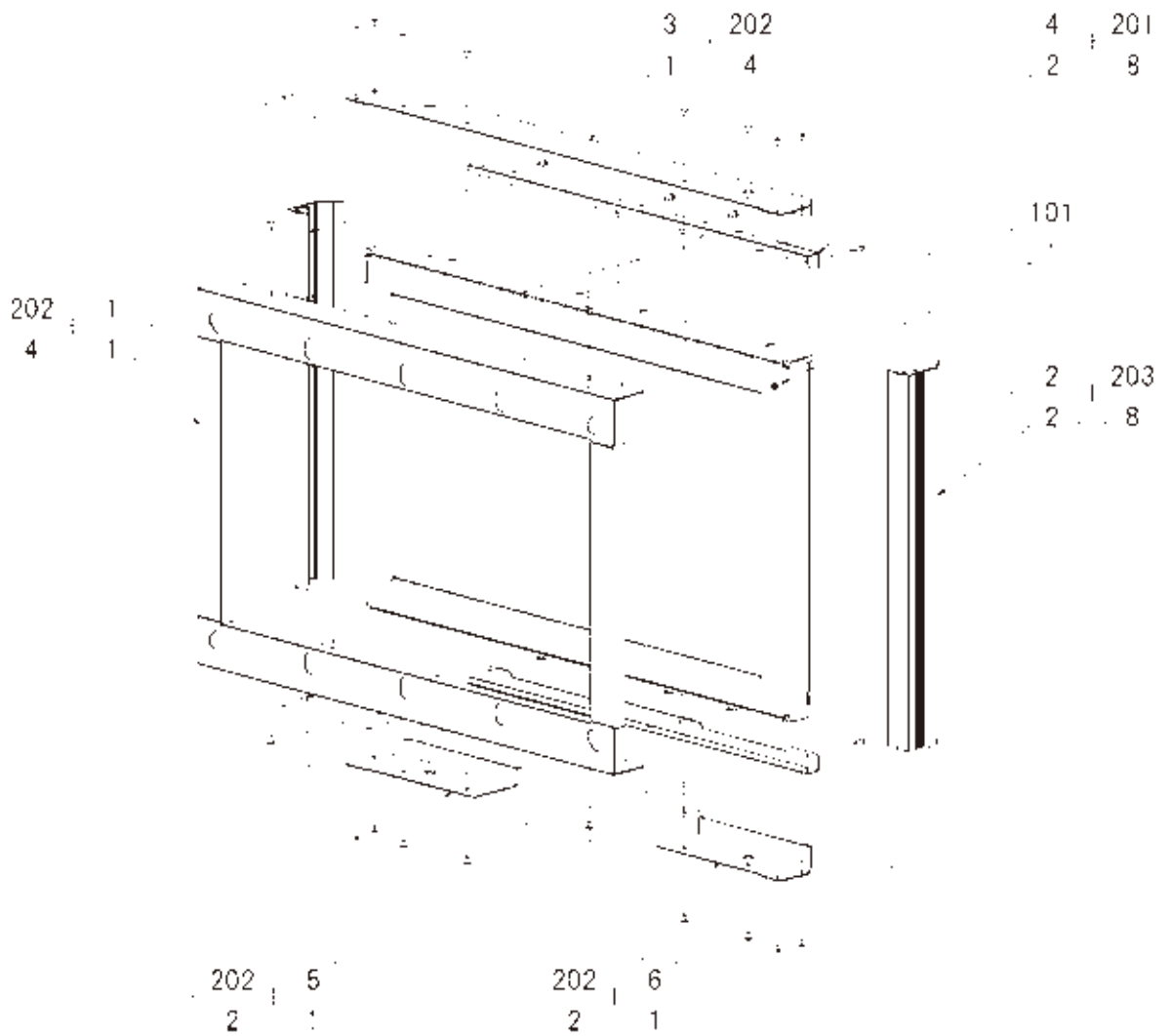

ITEM NO.	PART NO.	DESCRIPTION	NOTE
1	APA-1620	ASSY MONITOR MASK	
2	APA-1601	LCD SIDE COVER	
3	APA-1602	FRAME COVER UPPER	
4	APA-1603	MASK BRKT	
5	APA-1604	FRAME COVER LOWER L	
6	APA-1605	FRAME COVER LOWER R	
101	200-6046-91	ASSY LCD DSPL 32TYPE K	
201	000-P00312	M SCR PH M3×12	
202	000-T00408-0B	M SCR TH BLK M4×8	
203	010-F00310-0B	S-TITE SCR FH BLK M3×10	

14 ASSY MONITOR MASK (APA-1620)

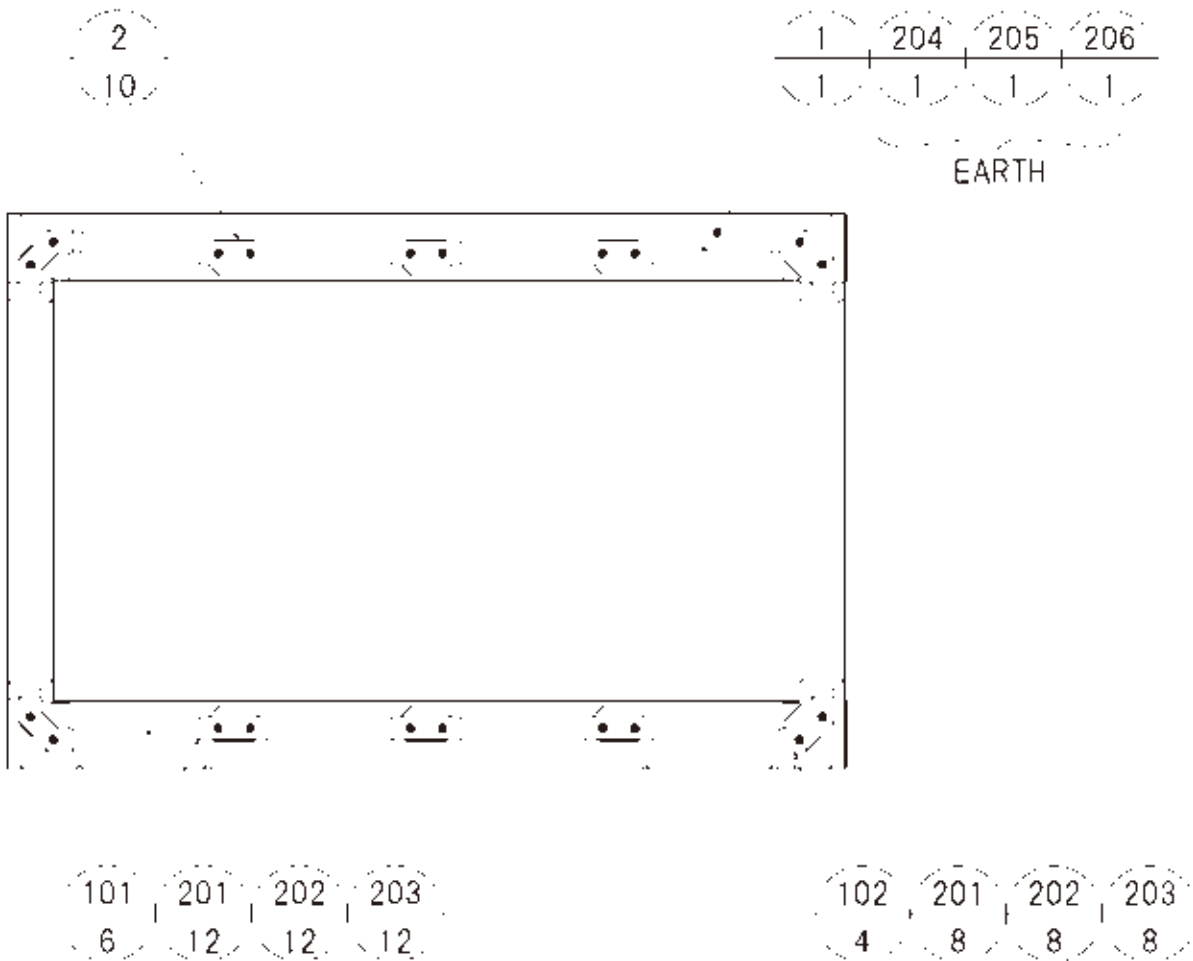

ITEM NO.	PART NO.	DESCRIPTION	NOTE
1	APA-1621	MASK BASE	
2	JPT-1082	IR COVER	
101	838-13145R02	LED BD GUN SENSE HOD	
102	838-14703	LED BD GUN SENSE APA	
103	280-5277	CORD CLAMP 18	
104	280-5275-SR10	CORD CLAMP SR10	
201	050-U00300	U NUT M3	
202	069-000034-PN	FLT WSHR PLASTIC BLK 3-8×1	
203	FAS-680016	FLT WSHR NI 3-10×0.5	
204	050-H00400	HEX NUT M4	
205	060-S00400	SPR WSHR M4	
206	060-F00400	FLT WSHR M4	
301	SPY-61013	WH MASK SHORT	
302	SPY-61014	WH MASK LONG	
303	APA-60037	WH LED MASK	
304	APA-60055	WH EARTH MASK	

15 ASSY TOWER L (APA-1700)

4 203 204 205
2 2 4 2

3 203 204 205
2 2 4 2

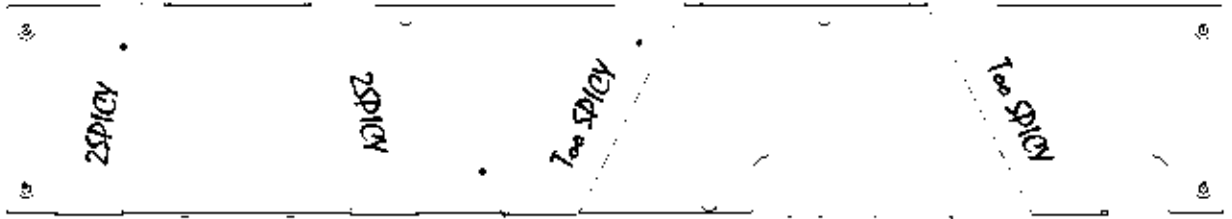

2 201 202 203 204
1 4 4 4 4

ITEM NO.	PART NO.	DESCRIPTION	NOTE
1	APA-1701	TOWER BASE L	
2	APA-1702	TOWER DESIGN PLATE L	
3	APA-1703	TAPE A	
4	APA-1704	TAPE B	
201	FAS-290042	HEX SKT LH CAP SCR STN M4×12	
202	280-6686-01	SP WSHR 4.5×16×4	
203	000-T00412-0B	M SCR TH BLK M4×12	
204	068-441616-0B	FLT WSHR BLK 4.4-16×1.6	
205	050-F00400	FLG NUT M4	

16 ASSY TOWER R (APA-1750)



ITEM NO.	PART NO.	DESCRIPTION	NOTE
1	APA-1751	TOWER BASE R	
2	APA-1752	TOWER DESIGN PLATE R	
3	APA-1703	TAPE A	
4	APA-1704	TAPE B	
201	FAS-290042	HEX SKT LH CAP SCR STN M4x12	
202	280-6686-01	SP WSHR 4.5x16x4	
203	000-T00412-0B	M SCR TH BLK M4x12	
204	068-441616-0B	FLT WSHR BLK 4.4-16x1.6	
205	050-F00400	FLG NUT M4	

17 ASSY PWR SPLY (APA-4000)

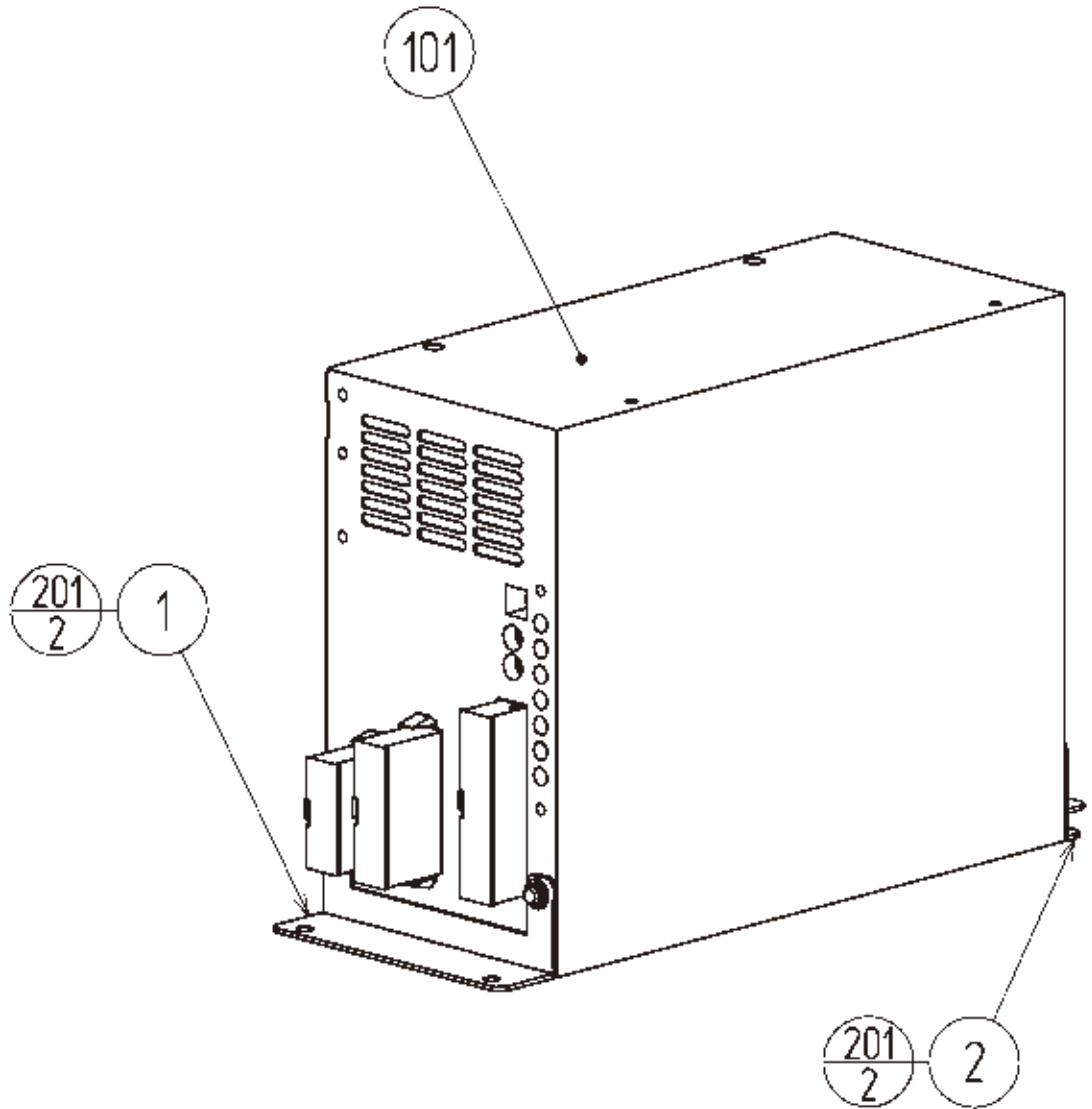

ITEM NO.	PART NO.	DESCRIPTION	NOTE
1	SHT-4904X	ELEC BRKT	
2	LCA-4001	ELEC BRKT	
101	400-5457-91	SW REGU ATX/JVS	
201	000-P00308-W	M SCR PH W/FS M3×8	

18 ASSY MAIN BD (APA-4100)

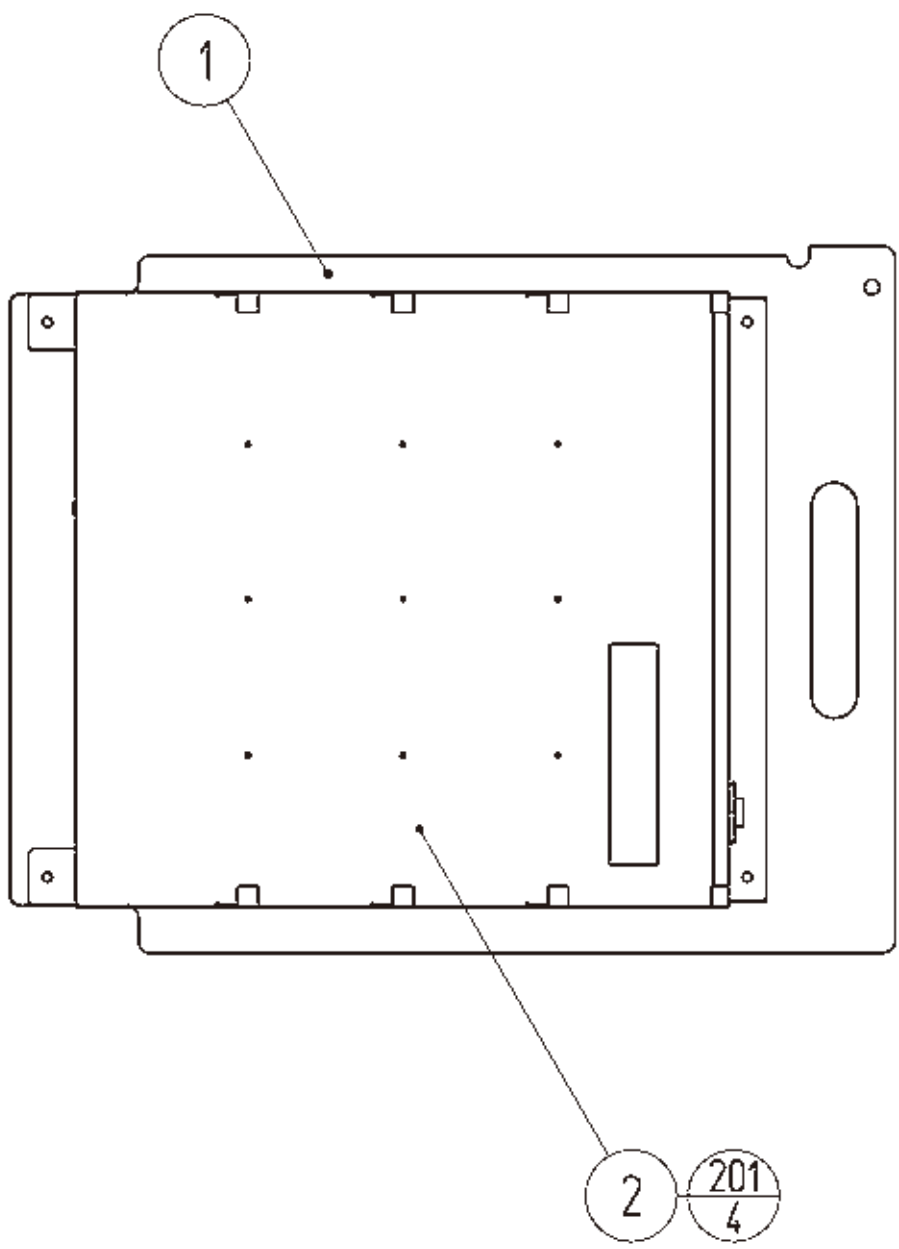

ITEM NO.	PART NO.	DESCRIPTION	NOTE
1	LCA-0001	WOODEN BASE MAIN	
2	845-0001D-02	ASSY CASE LBJ L 512MB EXP	
201	000-P00416-W	M SCR PH W/FS M4×16	

19 ASSY SUB ELEC (APA-4150)

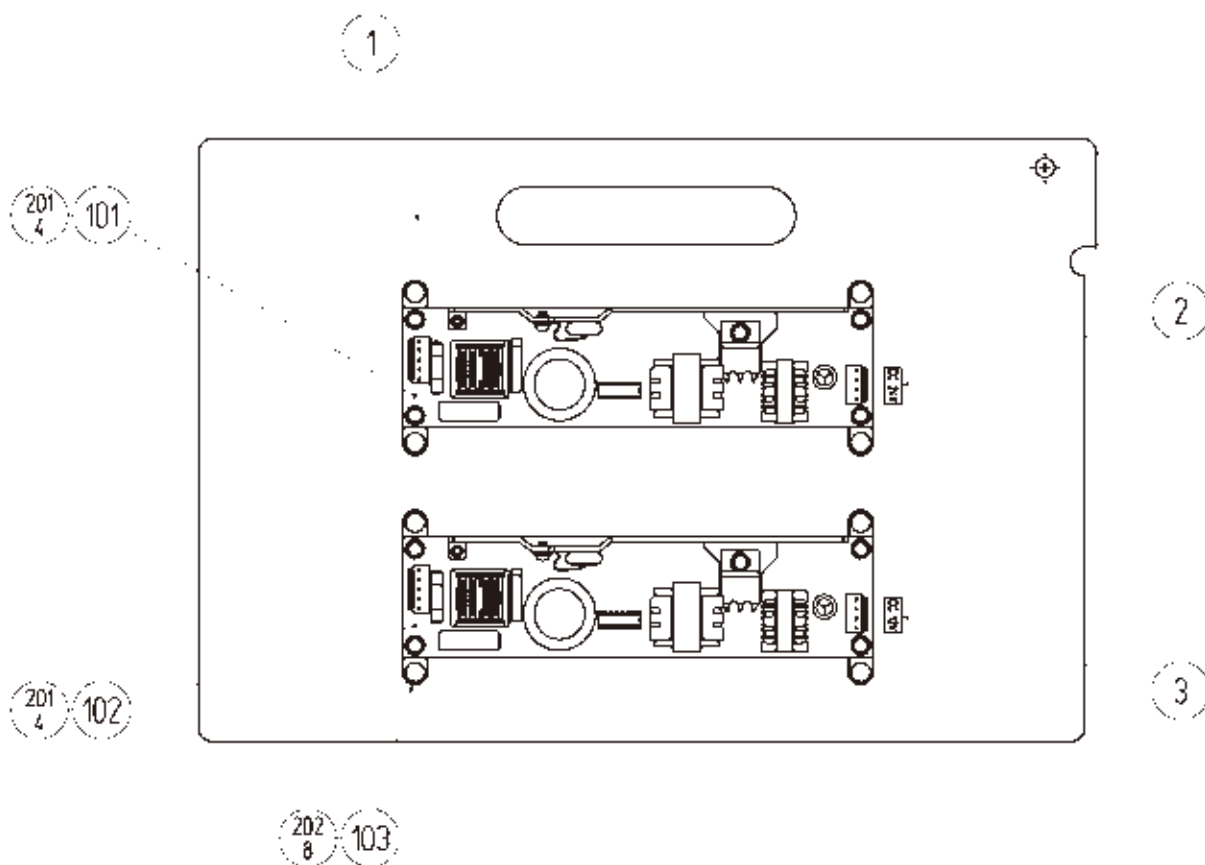

ITEM NO.	PART NO.	DESCRIPTION	NOTE
1	APA-4151	WOODEN BASE SUB	
2	421-9693-24	STICKER DC 24V	
3	421-9693-12	STICKER DC 12V	
101	400-5421-05024	SW REGU LCA50S-24	
102	400-5421-05012	SW REGU LCA50S-12	
103	280-6681	L-LOCK LT-320PCG	
104	280-0419	HARNESS LUG	
105	280-5277	CORD CLAMP 18	
201	000-P00308-W	M SCR PH W/FS M3×8	
202	011-T03516	TAP SCR TH 3.5×16	
203	011-T03512	TAP SCR TH 3.5×12	
204	011-F00312	TAP SCR #1 FH 3×12	
301	APA-60003	WH AC100V SUB ELEC	
302	APA-60004	WH DC OUT SUB ELEC	

20 ASSY ELEC FRONT (APA-4200)

202
4 101

1

103 202
4

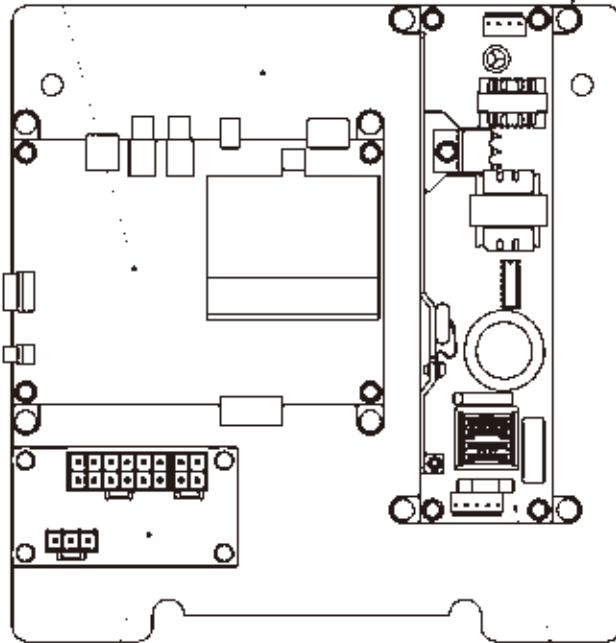

203
4 104

102 201
4

ITEM NO.	PART NO.	DESCRIPTION	NOTE
1	LCA-4051	WOODEN BASE SUB ELEC	
101	838-14515-A05	SOUND AMP ANALOG IN	
102	400-5421-05024	SW REGU LCA50S-24	
103	280-6681	L-LOCK LT-320PCG	
104	838-14551	DISTRIBUTION BD	
105	280-0419	HARNESS LUG	
201	000-P00308-W	M SCR PH W/FS M3×8	
202	011-T03516	TAP SCR TH 3.5×16	
203	011-P00320	TAP SCR PH 3×20	
301	LCA-60007	WH AC SUB ELEC SW REGU FOR AMP	
302	APA-60039	WH DC SUB ELEC SW REGU FOR AMP	

21 ASSY XFMR 100-120V (APA-4400)

1

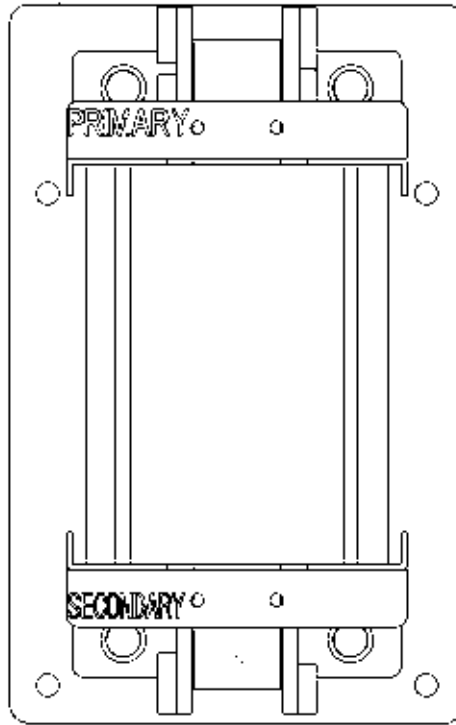

101 201
4

ITEM NO.	PART NO.	DESCRIPTION	NOTE
1	LCA-4201	WOODEN BASE XFMR	
101	560-5523-V	XFMR 100-120V 100V7.5A WB V	
102	280-0419	HARNESS LUG	
201	000-P00416-W	M SCR PH W/FS M4×16	
202	011-T03512	TAP SCR TH 3.5×12	

21 ASSY XFMR 220-240V (APA-4450)

1

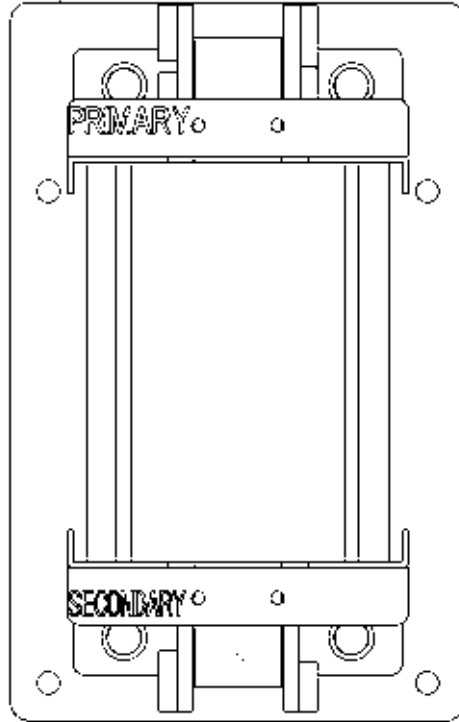

101 201
4

ITEM NO.	PART NO.	DESCRIPTION	NOTE
1	LCA-4201	WOODEN BASE XFMR	
101	560-5524-V	XFMR 220-240V 100V7.5A WB V	
102	280-0419	HARNESS LUG	
201	000-P00416-W	M SCR PH W/FS M4×16	
202	011-T03512	TAP SCR TH 3.5×12	

22 ASSY WIRE FRONT (APA-6001-01)

This is comprised of the following wire harnesses. ASSY drawing is not available.

ITEM NO.	PART NO.	DESCRIPTION	NOTE
101	601-0460	PLASTIC TIE BELT 100 MM	
301	600-7009-2500	ASSY RGB CA D-SUB 15P 2500MM	
302	600-7919-150	CBL AUD RCA TO MINI PLUG 150CM	
303	APA-60041	WH AC BASE SERVICEMAN SW	
304	APA-60001	WH AC100V FRONT CABINET	
305	APA-60006	WH DC24V FRONT CABINET	
306	APA-60007	WH DC12V FRONT CABINET	
308	APA-60009	WH WOOFER FRONT CABINET	
309	APA-60010	WH SPEAKER FRONT CABINET	
310	APA-60011	WH VOLUME FRONT CABINET	
311	APA-60036	WH LED FRONT CABINET	
312	APA-60052	WH EARTH BASE CABINET	
313	APA-60042	WH AC BASE XFMR OUT	



NOTE: "##" sign shows the actual dimensions along the side.

23 ASSY REAR CABINET (APA-3000)**(D-2/2)**

ITEM NO.	PART NO.	DESCRIPTION	NOTE
1	APA-3100	ASSY BASE CABINET REAR	
2	APA-2100	CONTROL UNIT	
3	APA-3200	ASSY PEDAL	
4	APA-3300	ASSY LED REAR	
5	APA-3400	SW UNIT	
6	APA-3450	COUNTER UNIT	
7	APA-4300	ASSY ELEC REAR	
8	APA-3001X	FOOT LID	
9	APA-3002	REAR LID	
10	APA-3003	WIRE COVER REAR	
11	APA-3004	CONTROLLER CABLE BRKT	
12	APA-3005	CONTROL PNL UPPER	
13	APA-3006-01	CONTROL PNL UNDER ENG	
14	APA-3007	CONTROL UNIT HOLDER	
15	APA-3008	EDY COVER	
16	APA-3010	STICKER CONTROL UNIT HOLDER	
17	APA-3011	STICKER REAR SIDE L	
18	APA-3012	STICKER REAR SIDE R	
19	APA-3013	STICKER REAR SPEAKER UNDER L	
20	APA-3014	STICKER REAR SPEAKER UNDER R	
21	APA-3015	STICKER REAR SPEAKER UPPER L	
22	APA-3016	STICKER REAR SPEAKER UPPER R	
23	APA-3017	STICKER REAR CENTER	
24	253-5366	CASH BOX	
26	421-11416	STICKER CAUTION FORK	
27	440-WS0002XEG	STICKER W POWER OFF ENG	
28	440-WS0165-EG	STICKER W BD POWER OFF S ENG	
29	440-WS0281-EG	STICKER W POWER OFF DGT ENG	
30	440-CS0323-EG	STICKER C APA PEDAL ENG	
31	APA-3018	FOOT LID SPONGE	
101	509-6144	SW OBSA-45AM-R-1FLED-R-12V APA	
201	030-000820-S	HEX BLT W/S M8×20	
202	060-F00800	FLT WSHR M8	
203	050-F00400	FLG NUT M4	
204	000-P00408-W	M SCR PH W/FS M4×8	
205	032-000425	WING BLT M4×25	
206	068-441616-0B	FLT WSHR BLK 4.4-16×1.6	
207	060-S00400	SPR WSHR M4	
208	000-T00408-0B	M SCR TH BLK M4×8	
209	000-P00412-W	M SCR PH W/FS M4×12	
210	FAS-290044	HEX SKT LH CAP SCR STN M4×16	
211	FAS-290042	HEX SKT LH CAP SCR STN M4×12	
212	280-6686-01	SP WSHR 4.5×16×4	
213	000-F00410	M SCR FH M4×10	
214	008-T00410-0B	TMP PRF SCR TH BLK M4×10	

24 ASSY BASE CABINET REAR (APA-3100)

(D-1/2)

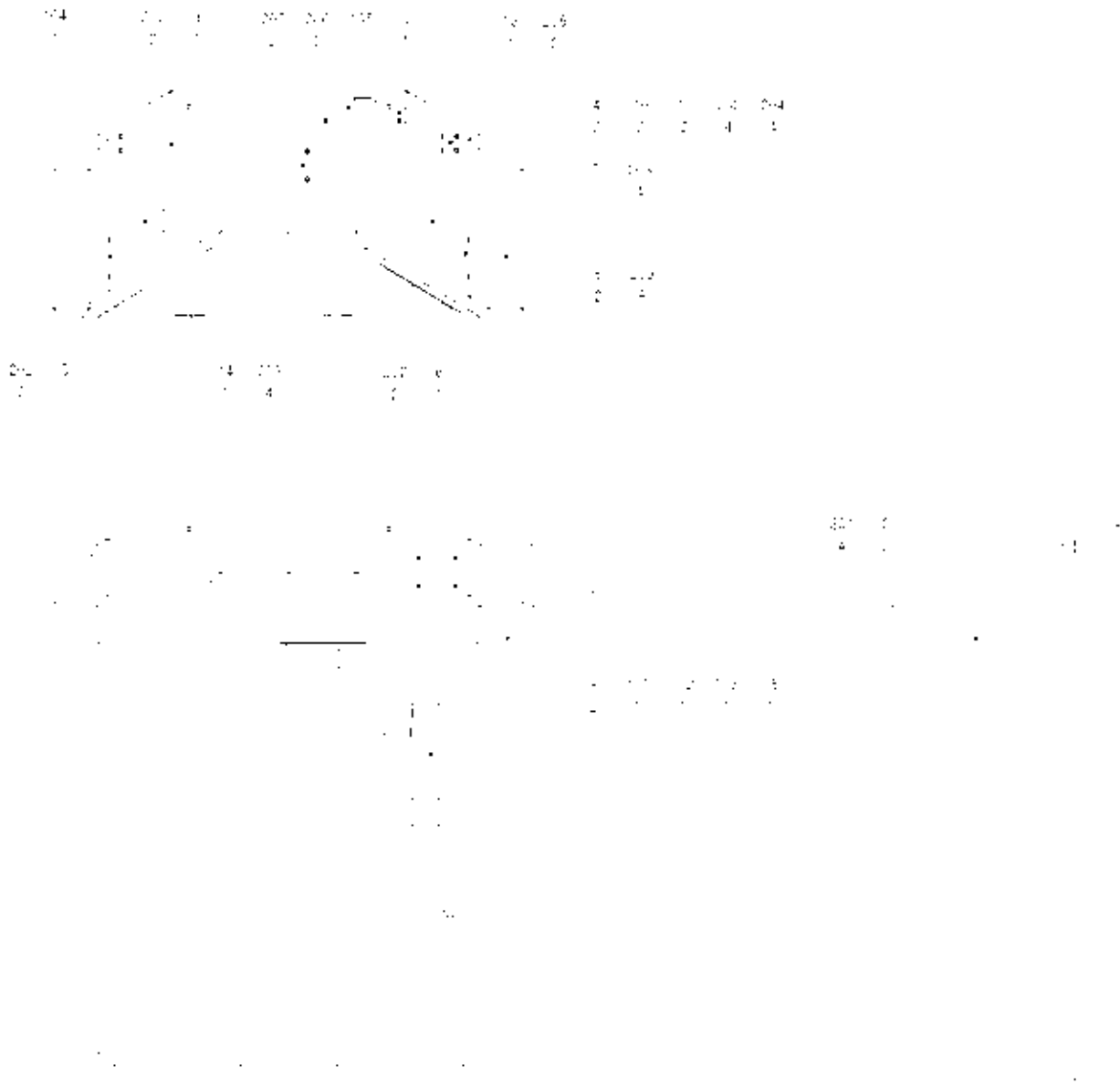

24 ASSY BASE CABINET REAR (APA-3100)

(D-2/2)

ITEM NO.	PART NO.	DESCRIPTION	NOTE
1	APA-3150	REAR CABINET	
2	APA-3500	ASSY SPEAKER	
3	APA-3102	CABLE HOLE LID	
4	APA-3103	CCFL HOLDER REAR	
5	APA-3104	SIDE WEATHER STRIP L	
6	APA-3105	SIDE WEATHER STRIP R	
7	105-5592	CHUTE PLATE SINGLE	
8	APA-3108	SPEAKER NET	
9	DP-1167	TNG LKG	
10	LCA-2037	CCFL CAP	
11	LCA-2041	CUSHION	
12	VTF-1573	CCFL INV SHEET	
13	VTF-1574	CCFL INV COVER	
14	839-1176R01	CONN BD JVS	
15	421-7501-02	STICKER 6.3V 0.15A	
101	220-5237-93-04	ASSY C.C 2DR TAIWAN NT \$10	<Taiwan>
	220-5237-93-37	ASSY C.C 2DR SINGAPORE \$1	<Singapore, Philippines, Malaysia, Indonesia>
	220-5237-93-09	ASSY C.C 2DR KOREA 100W	<Korea>
	220-5237-93-05	ASSY C.C 2DR HONG KONG \$10	<Hong Kong>
	220-5237-93-08	ASSY C.C 2DR AUSTRALIA \$1	<Australia>
102	220-5793-1-A001	CLY LOCK MASTER W/O KEY A001	
103	220-5794	CLY LOCK W/KEYS	
104	390-6859-YE-V	CCFL L=495 D=15 YE W/TUBE	
105	838-14587	CCFL INV ELEVAM S-12647C-8M	
106	280-5275-SR10	CORD CLAMP SR10	
107	280-5277	CORD CLAMP 18	
108	310-5029-F20	SUMITUBE F F 20MM	
109	601-0460	PLASTIC TIE BELT 100 MM	
201	000-P00408-W	M SCR PH W/FS M4×8	
202	050-F00400	FLG NUT M4	
203	050-U00400	U NUT M4	
204	012-P00308	TAP SCR #2 PH 3×8	
205	000-P00310-W	M SCR PH W/FS M3×10	
206	000-P02610	M SCR PH M2.6×10	
207	FAS-680011	FLT WSHR POLY 2.7-6×0.5	
208	000-P00320-W	M SCR PH W/FS M3×20	
209	000-F00306	M SCR FH M3×6	
301	APA-6002	ASSY WIRE REAR	
302	APA-60018	WH DC24V REAR CABINET	
303	APA-60019	WH DC12V REAR CABINET	
304	APA-60020	WH DC5V REAR CABINET	
305	APA-60029	WH PEDAL REAR CABINET	
306	APA-60033	WH LED REAR CABINET	
307	600-7368-02	WH C.C DOOR SINGLE JAMMA COLOR	
308	APA-60038	WH FREQ	
309	600-7141-91-050	CABLE JVS TYPE A-B 050CM	
310	APA-60034	WH CONTROLLER REAR CABINET	

25 REAR CABINET (APA-3150)

(D-1/2)

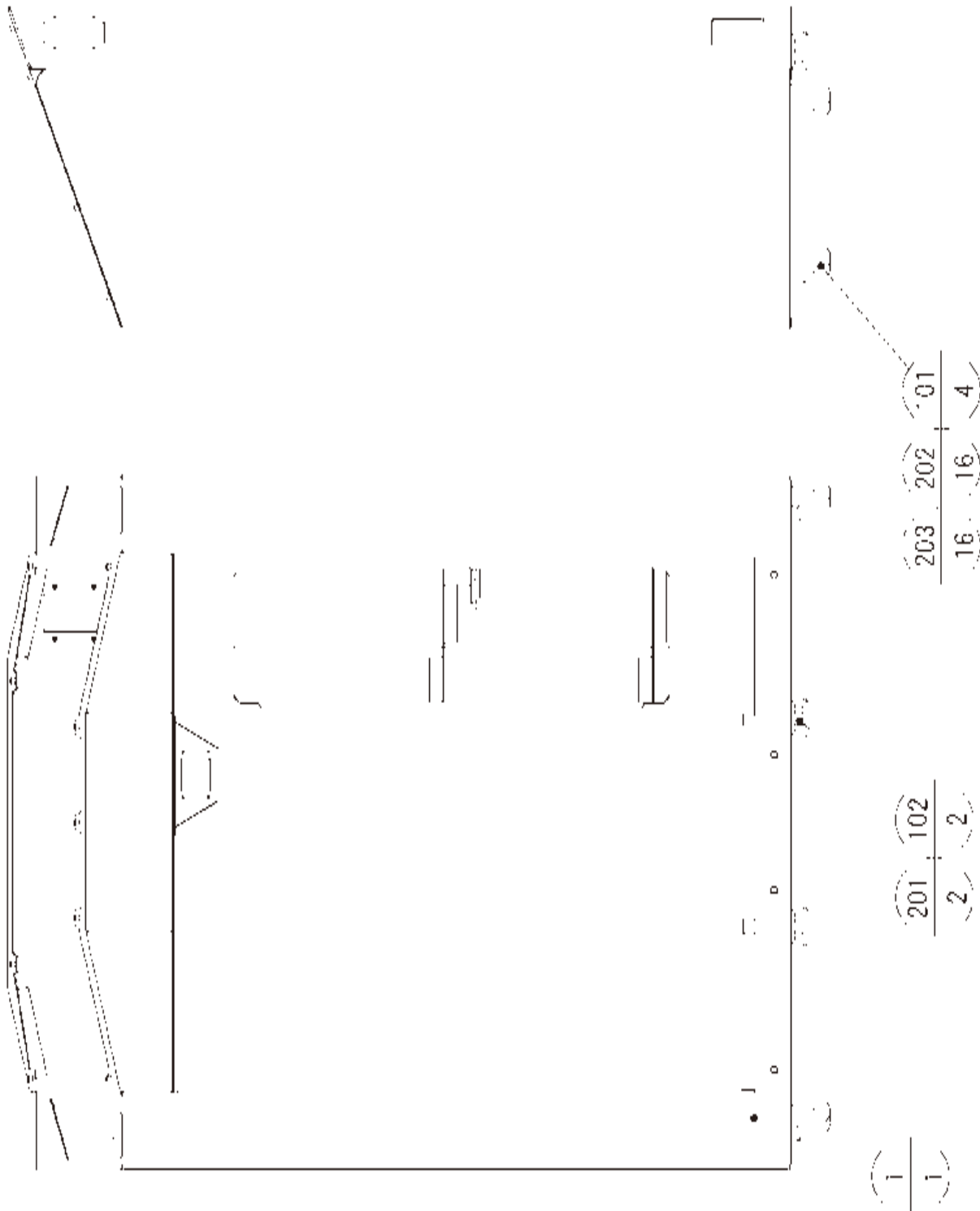

25 REAR CABINET (APA-3150)**(D-2/2)**

ITEM NO.	PART NO.	DESCRIPTION	NOTE
1	APA-3151	REAR CABINET BLANK	
101	601-10905	CASTER D51H66 FREE ST	
102	601-11546	LEG ADJUSTER BOLT M16×60 DISGO	
201	050-H01600	HEX NUT M16	
202	030-000616-S	HEX BLT W/S M6×16	
203	060-F00600	FLT WSHR M6	

26 ASSY SPEAKER (APA-3500)

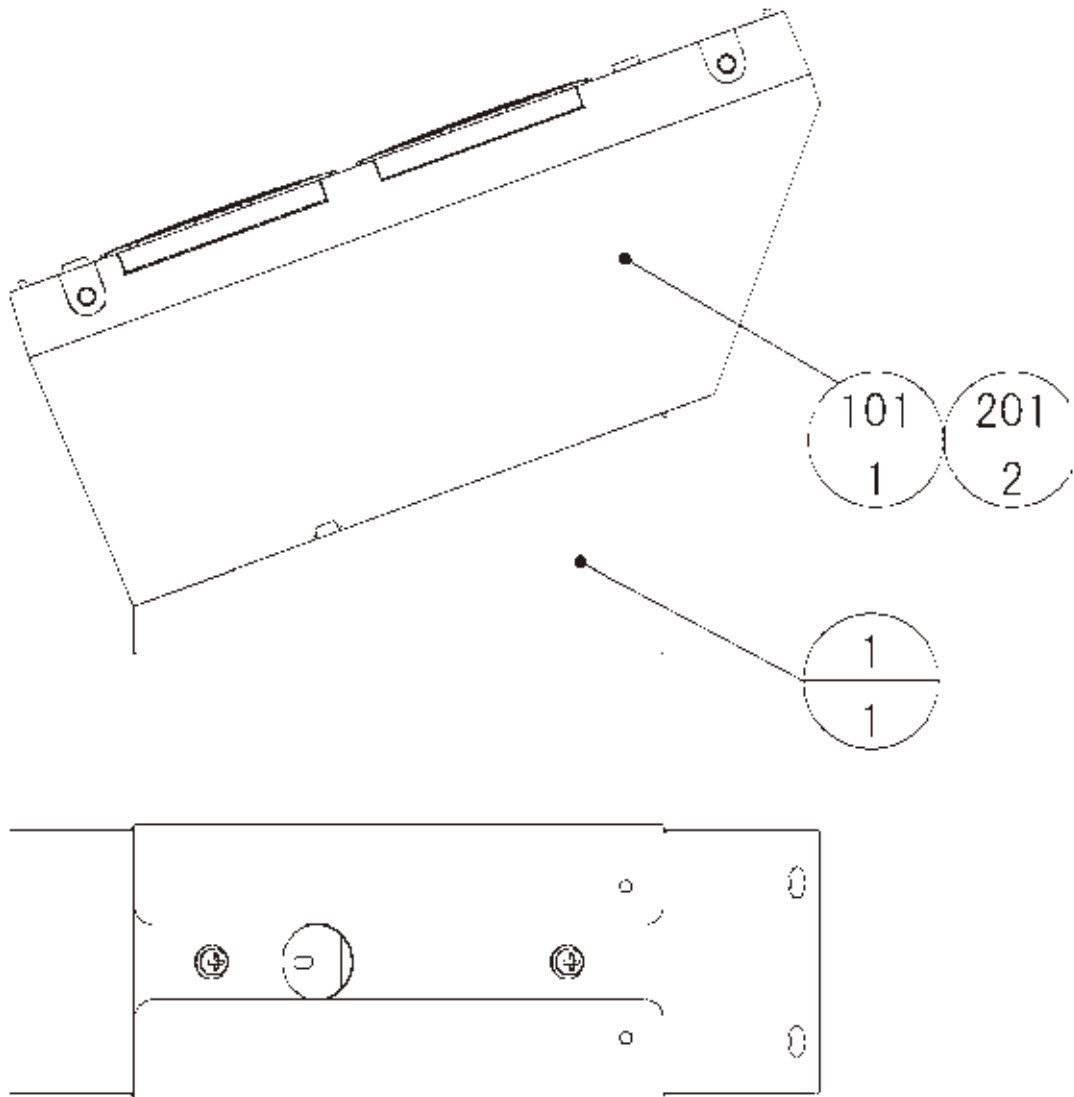

ITEM NO.	PART NO.	DESCRIPTION	NOTE
1	APA-3501	SPEAKER BRKT	
101	130-5260	SPKR BOX 6OHM 15/40W W/SHLD	
102	280-5275-SR10	CORD CLAMP SR10	
201	000-P00408-W	M SCR PH W/FS M4×8	

27 ASSY WIRE REAR (APA-6002)

This is comprised of the following wire harnesses. ASSY drawing is not available.

ITEM NO.	PART NO.	DESCRIPTION	NOTE
101	601-0460	PLASTIC TIE BELT 100 MM	
301	APA-60021	WH SPEAKER REAR CABINET	
302	APA-60022	WH START & SWUNIT REAR CABINET	
303	APA-60030	WH LAMP REAR CABINET	
304	APA-60032	WH COIN & METER REAR CABINET	



28 ASSY PEDAL (APA-3200)**(D-2/2)**

ITEM NO.	PART NO.	DESCRIPTION	NOTE
1	APA-3201	PEDAL BASE	
2	APA-3202	PEDAL	
3	APA-3203	PEDAL COVER CENTER BASE	
5	APA-3205	PEDAL COVER	
6	APA-3206	PEDAL SIDE LID	
7	APA-3207	SIDE SASH L	
8	APA-3208	SIDE SASH R	
9	APA-3209	COM SPRING	
11	VCT-1205	SPRING COVER	
12	APA-3217X	SHADE PLATE	
13	VCT-1207X	SENSOR BRKT	
14	VCT-1209	STOPPER RUBBER	
15	VCT-1210	RUBBER CUSHION	
16	VCT-1211X	RUBBER CASE	
17	APA-3216	FOOTPRINT PLATE	
21	APA-3214	PEDAL PLATE L	
22	APA-3215	PEDAL PLATE R	
101	370-5173-01	PHOTO SENSOR OMT-15DJST-YL	
102	280-5275-SR10	CORD CLAMP SR10	
103	280-5277	CORD CLAMP 18	
104	280-6622-30030	SPACER TUBE	
201	050-F00400	FLG NUT M4	
202	031-0S0412	CRG BLT STN M4×12	
203	000-T00408-0C	M SCR TH CRM M4×8	
204	000-T00408-0B	M SCR TH BLK M4×8	
205	FAS-290057	HEX SKT LH CAP SCR STN M5×8	
206	000-F00512	M SCR FH M5×12	
207	000-P00312-W	M SCR PH W/FS M3×12	
208	250-5421	FLT WSHR 3.5-12 T=1.0	
209	031-0S0416	CRG BLT STN M4×16	
301	APA-60031	WH FOOT PEDAL	

29 ASSY LED REAR (APA-3300)

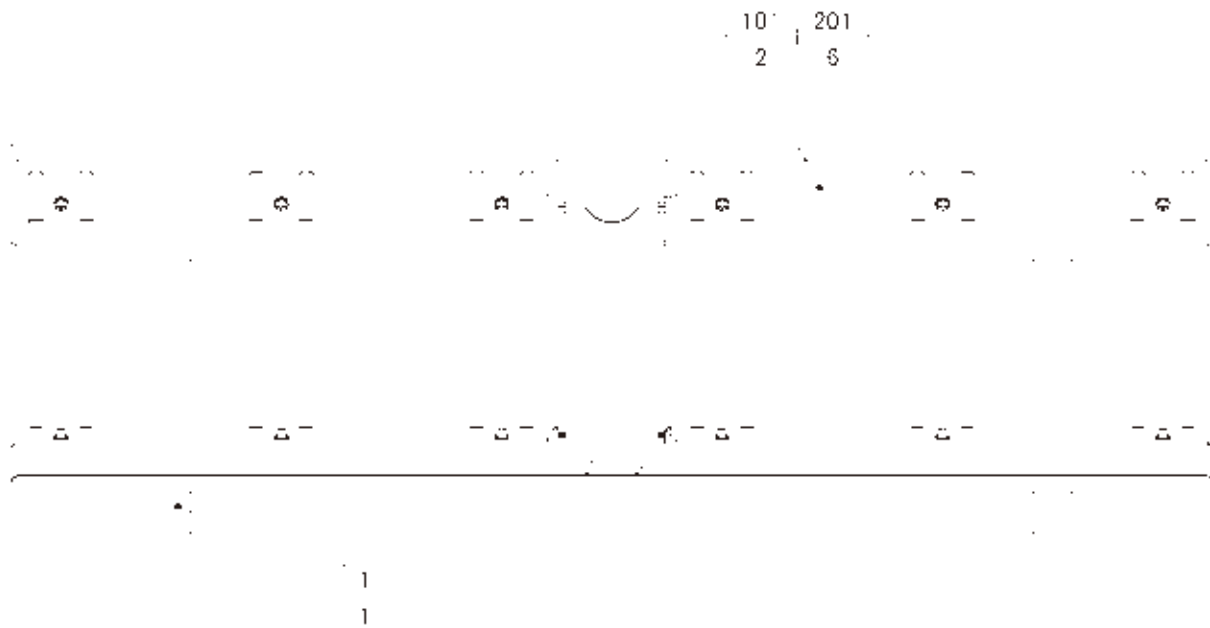

ITEM NO.	PART NO.	DESCRIPTION	NOTE
1	APA-3301	LED BASE REAR	
101	838-14731	RED LED BD APA	
102	280-5275-SR10	CORD CLAMP SR10	
201	000-P00320-W	M SCR PH W/FS M3×20	

30 SW UNIT (APA-3400)

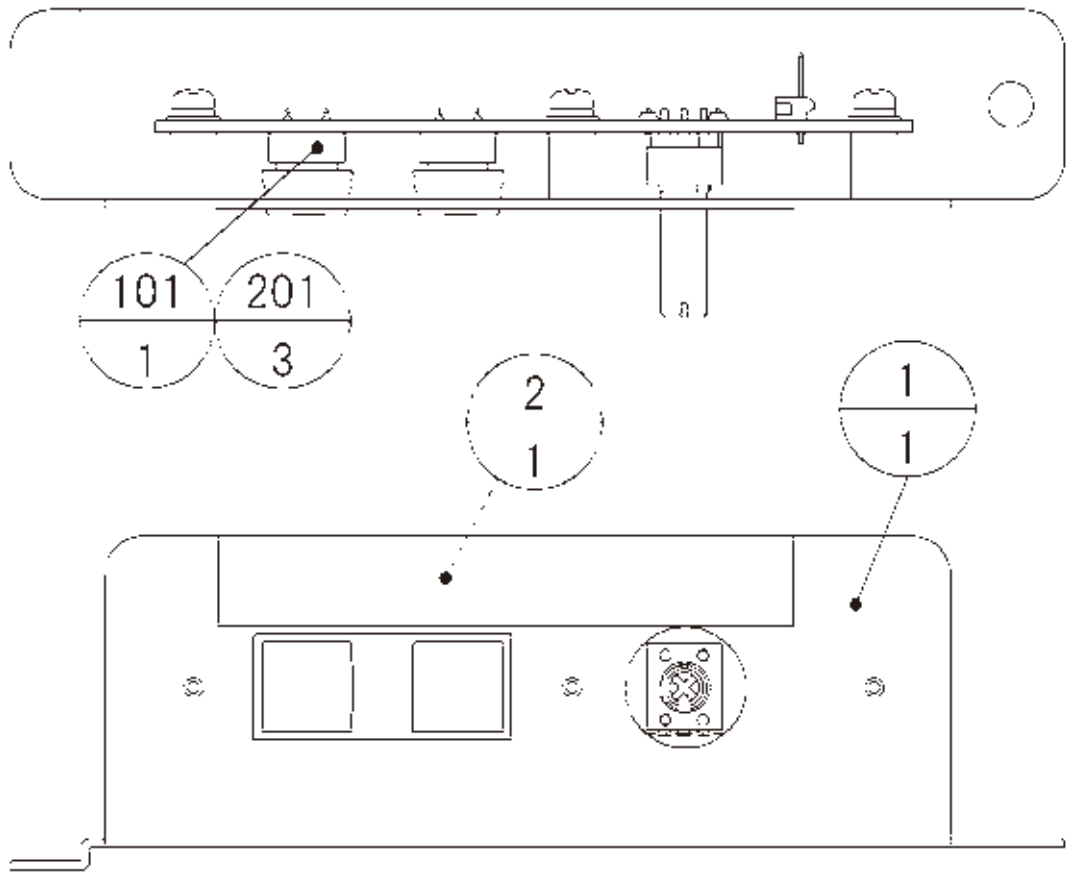

ITEM NO.	PART NO.	DESCRIPTION	NOTE
1	APA-3401	SW UNIT BRKT	
2	421-12043	STICKER SW PANEL	
101	838-14548-01	SW & C VOL BD	
201	000-P00308-W	M SCR PH W/FS M3x8	

31 COUNTER UNIT (APA-3450)

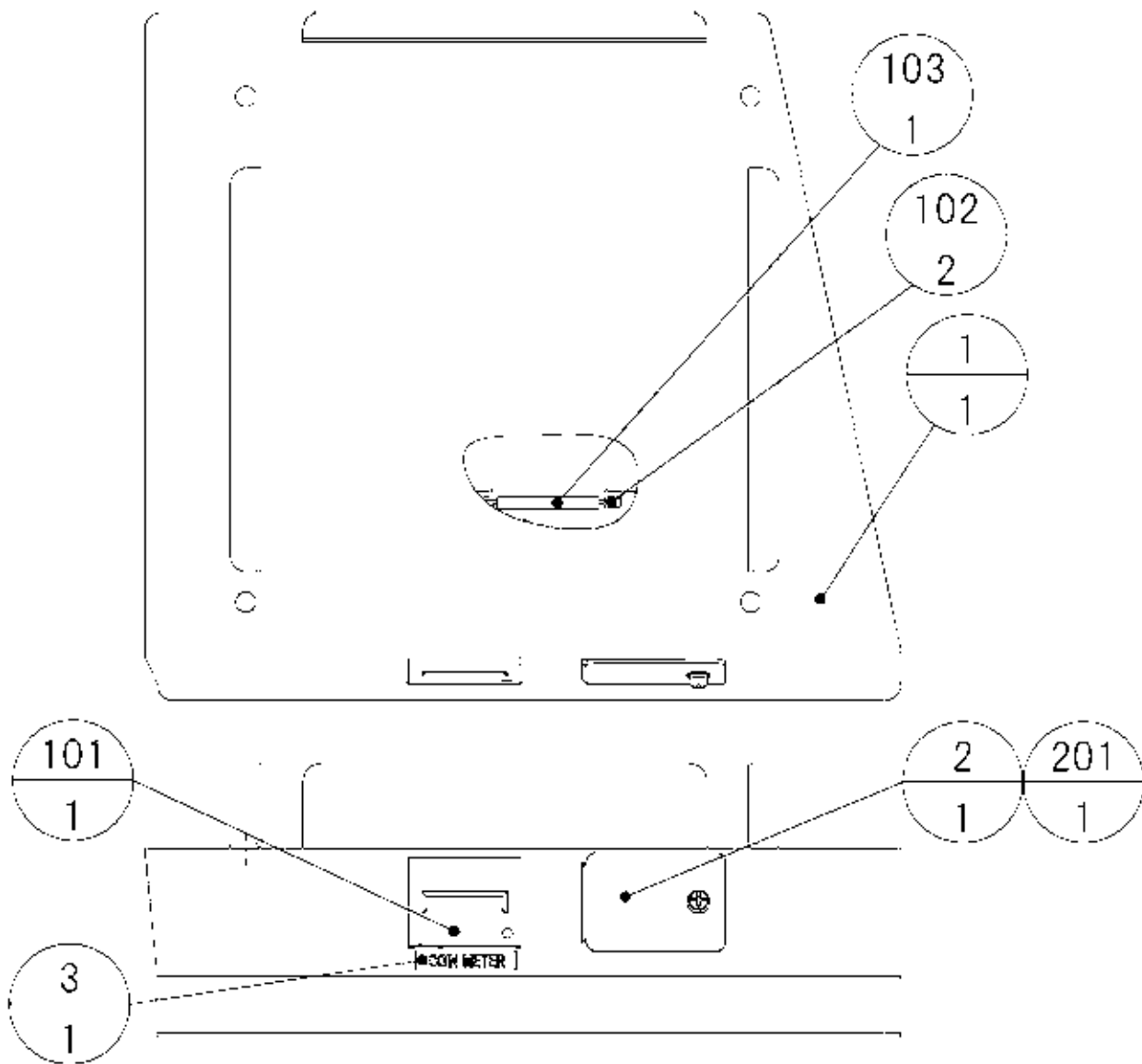

ITEM NO.	PART NO.	DESCRIPTION	NOTE
1	APA-3451	COUNTER BRKT	
2	TBA-1509	COUNTER LID	
3	421-9168-01	STICKER COIN METER	
101	220-5798-01	MAG CNTR 4P MZ674-DC5V-D41 JC	
102	601-6231-B010	EDGING NEW TYPE L=10MM	
103	601-6231-B010	EDGING NEW TYPE L=30MM	
104	280-5275-SR10	CORD CLAMP SR10	
201	000-P00308-W	M SCR PH W/FS M3×8	

32 CONTROL UNIT (APA-2100)

(D-1/2)

18 PARTS LIST

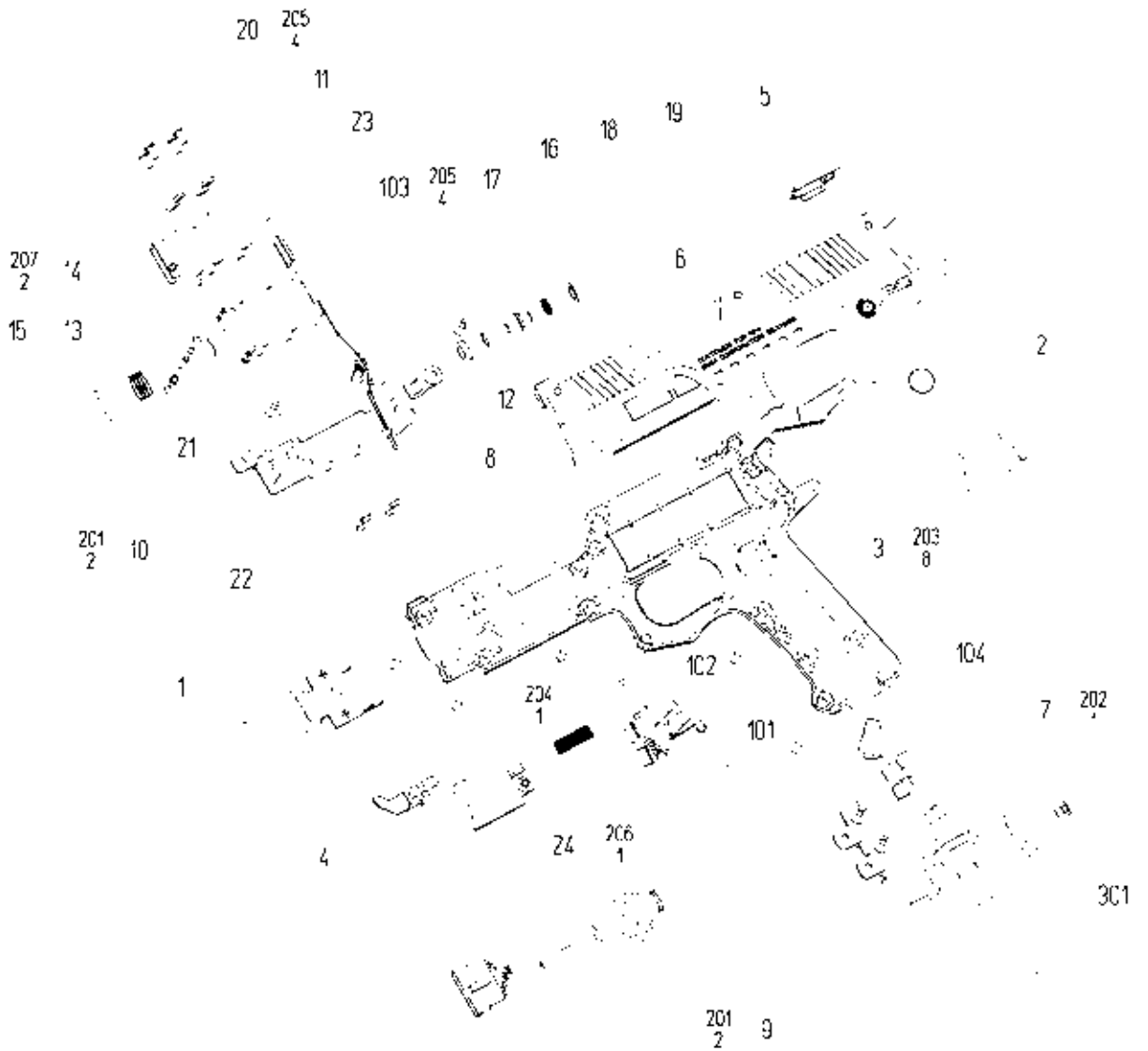

32 CONTROL UNIT (APA-2100)**(D-2/2)**

ITEM NO.	PART NO.	DESCRIPTION	NOTE
1	APA-2130	SENSOR UNIT (OMJ-GZH200-W)	
2	APA-2101	COVER LEFT	
3	APA-2102	COVER RIGHT	
4	APA-2103	TRIGGER	
5	APA-2104	SIGHT	
6	APA-2105	STICKER CTRL SIDE	
7	APA-2106	CORD FRAME COVER	
8	APA-2107	CORD CLAMP	
9	APA-2108	CORD FRAME	
10	APA-2109	SOLENOID FRAME	
11	APA-2110	SLIDE FRAME	
12	APA-2111	SOLENOID DAMPER	
13	APA-2112	SOLENOID SPRING	
14	APA-2113	SOLENOID SHAFT	
15	APA-2114	SOLENOID WSHR	
16	APA-2115	WEIGHT	
17	APA-2116	DAMPER COLLAR	
18	APA-2117	WEIGHT SPRING	
19	APA-2118	WEIGHT WSHR	
20	APA-2119	SLIDE BASE UPPER	
21	APA-2123	BUSH	
22	APA-2124	PLUG CUSHION	
23	APA-2120	SLIDE BASE LOWER	
24	CTF-2123	TRIGGER SPRING	
101	509-5080	SW MICRO TYPE (SS-5GL2)	
102	310-5029-D20	SUMITUBE F D 20MM	
103	124-5101	SOLENOID DC24V	
104	280-5275-SR10	CORD CLAMP SR10	
201	000-P00408-W	M SCR PH W/FS M4×8	
202	FAS-000188	M SCR PH W/SMALL FS BLK M4×8	
203	FAS-000100	M SCR PH W/SMALL FS BLK M3×12	
204	FAS-000099	M SCR PH W/SMALL FS BLK M3×10	
205	000-P00308-S	M SCR PH W/S M3×8	
206	000-F00308-OB	M SCR FH BLK M3×8	
207	065-E00200	E RING 2MM	
301	APA-60035	WH CONTROLLER	

33 ASSY ELEC REAR (APA-4300)

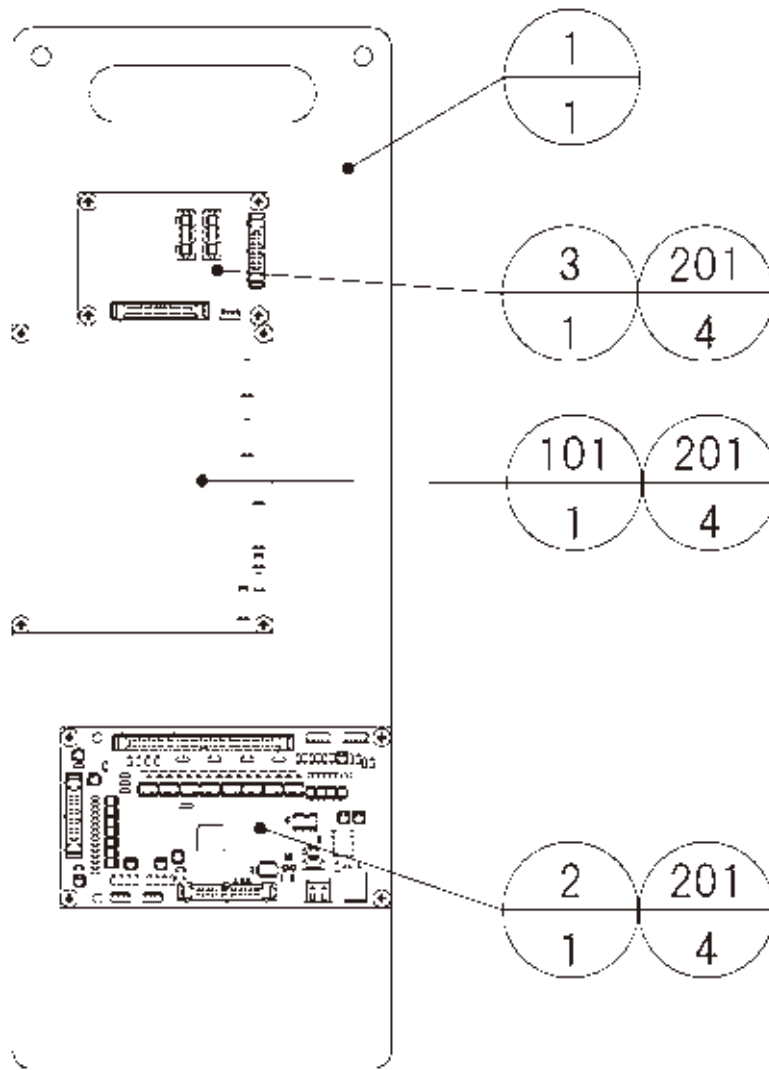

ITEM NO.	PART NO.	DESCRIPTION	NOTE
1	APA-4301	ELEC BASE REAR	
2	837-14572	I/O CONTROL BD 3 FOR JVS COM	
3	839-1243-01	FUSE BD APA	
101	838-14465R03	IC BD G.SENSE 1P(OMC-GZH200-H)	
102	280-5277	CORD CLAMP 18	
201	011-P00320	TAP SCR PH 3×20	
202	011-F00312	TAP SCR #1 FH 3×12	
301	APA-60023	WH DC24V REAR ELEC	
302	APA-60024	WH DC12V REAR ELEC	
303	APA-60025	WH DC5V REAR ELEC	
304	APA-60026	WH LAMP REAR ELEC	
305	APA-60027	WH I/O REAR ELEC	
306	APA-60028	WH LED REAR ELEC	

34 ASSY TUBE (APA-0100)

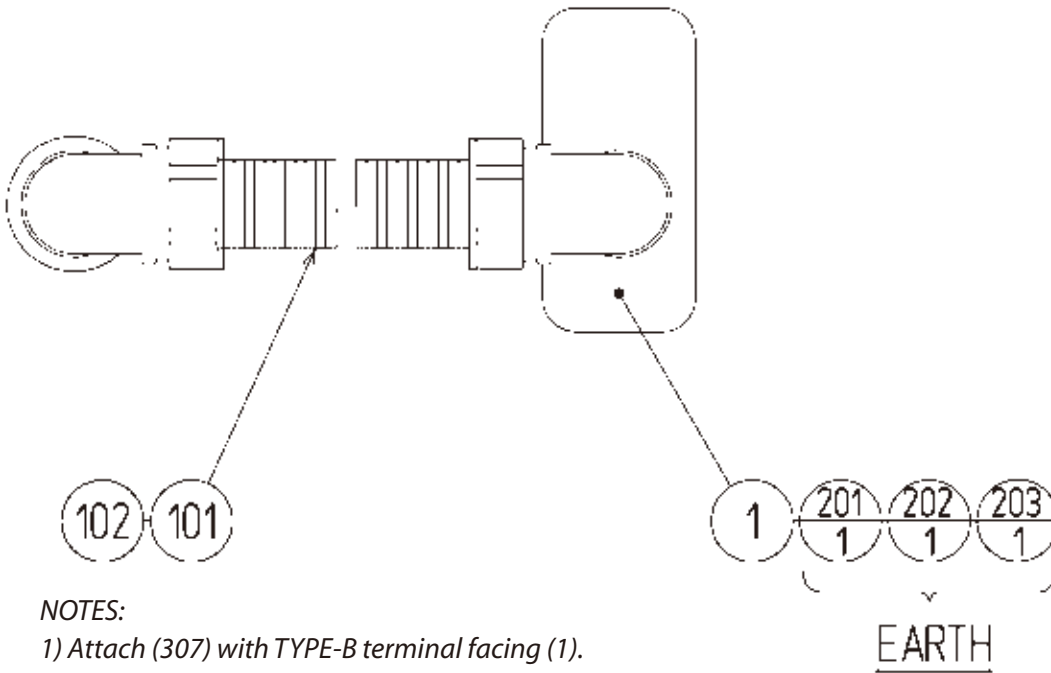

NOTES:
 1) Attach (307) with TYPE-B terminal facing (1).
 2) Attach (308) with round terminal facing (1).

ITEM NO.	PART NO.	DESCRIPTION	NOTE
1	APA-0101	TUBE BRKT	
101	310-5050-220050	FLEX TUBE 22-0050CM	
102	310-5053-22	CONN L 22	
201	050-H00400	HEX NUT M4	
202	060-S00400	SPR WSHR M4	
203	060-F00400	FLT WSHR M4	
301	APA-60012	WH DC24V TUBE	
302	APA-60013	WH DC12V TUBE	
303	APA-60014	WH DC5V TUBE	
304	APA-60015	WH SPEAKER TUBE	
305	APA-60016	WH VOLUME TUBE	
306	APA-60017	WH LED TUBE	
307	600-7141-91-150	CABLE JVS TYPE A-B 150CM	
308	APA-60053	WH EARTH TUBE	

19 WIRE COLOR CODE TABLE

STOP IMPORTANT

The DC power wire color for this product is different from previous SEGA titles. Working from the previous wire colors will create a high risk of fire.

The color codes for the wires used in the diagrams in the following chapter are as follows.

A	PINK
B	SKY BLUE
C	BROWN
D	PURPLE
E	LIGHT GREEN

Wires other than those of any of the above 5 single colors will be displayed by 2 alphanumeric characters.

1	RED
2	BLUE
3	YELLOW
4	GREEN
5	WHITE
7	ORANGE
8	BLACK
9	GRAY

If the right-hand side numeral of the code is 0, then the wire will be of a single color shown by the left-hand side numeral (see the above).

Note 1: If the right-hand side numeral is not 0, that particular wire has a spiral color code. The left-hand side character shows the base color and the right-hand side one, the spiral color.

<Example> 51.....WHITE/RED

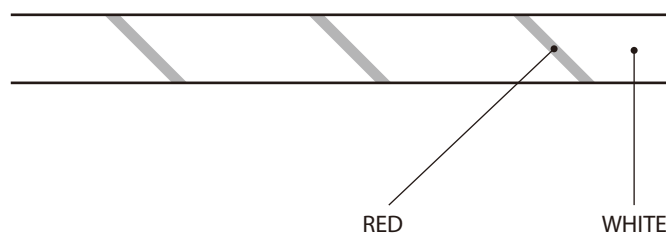

Note 2: The character following the wire color code indicates the size of the wire.

U:	AWG16
K:	AWG18
L:	AWG20
None:	AWG22

20 WIRING DIAGRAM (D-1/3)

