



OWNERS AND SERVICE MANUAL

INNOVATIVE CONCEPTS IN ENTERTAINMENT INC.

10123 MAIN STREET, CLARENCE, NY 14031

SERVICE: 1-716-759-0360

FAX: 1-716-759-0884

E-MAIL: service@icegame.com

WEBSITE: www.icegame.com

TABLE OF CONTENTS

SAFETY & WARNINGS.....	PAGE 3
• BEFORE YOU BEGIN	
• INSTALLATION	
• WARNING	
GAME SETUP & FEATURES.....	PAGE 4 - 5
• PLAYER CONTROLS	
• PLAYING THE GAME	
• INITIAL GAME SETUP	
DIAGNOSTIC, ADJUSTMENT & AUDIT MENU SYSTEM.....	PAGE 6 - 12
• MENU SYSTEM	
• STARTING THE MENU SYSTEM	
• NAVIGATING THE MENU	
• MAIN MENU	
• VIEW COIN AUDITS	
• VIEW TICKET AUDITS	
• VIEW SYSTEM AUDITS	
• COINAGE ADJUSTMENTS	
• TICKET ADJUSTMENTS	
• SYSTEM ADJUSTMENTS	
• GAME ADJUSTMENTS	
• RESET MENU	
TROUBLESHOOTING.....	PAGE 13 - 14
MAINTENANCE.....	PAGE 15 - 18
• CLEANING GLASS & MONITOR	
• REPLACING MARQUEE LIGHT BULB	
• GUN REPAIR	
PARTS LISTING.....	PAGE 19
SCHEMATICS.....	PAGE 20
JAMMA CONNECTOR PINOUT CHART.....	PAGE 21
WARRANTY INFORMATION.....	PAGE 22 - 23

SAFETY AND WARNINGS

BEFORE YOU BEGIN

WARNING: WHEN INSTALLING THIS GAME, A GROUNDED A.C. RECEPTACLE MUST BE USED. FAILURE TO DO SO COULD RESULT IN INJURY TO YOURSELF OR OTHERS. FAILURE TO USE A GROUNDED RECEPTACLE COULD ALSO CAUSE IMPROPER GAME OPERATION, OR DAMAGE TO THE ELECTRONICS.

DO NOT DEFEAT OR REMOVE THE GROUNDING PRONG ON THE POWER CORD FOR THE SAME REASON AS GIVEN ABOVE. USING AN IMPROPERLY GROUNDED GAME COULD VOID YOUR WARRANTY.

HAVE A QUALIFIED ELECTRICIAN CHECK YOUR A.C. RECEPTACLE TO BE SURE THE GROUND IS FUNCTIONING PROPERLY.

INSTALLATION

The game comes ready to play with just a few simple things to keep in mind.

1. Plug the game into the A.C. outlet and turn on power to the game. The switch for the game is located on a power module on the outside rear of the game.

THIS GAME IS DESIGNED TO DISSIPATE STATIC ELECTRICITY THROUGH THE GROUNDING PLANE OF THE GAME. IF THE A.C. GROUND DOES NOT WORK, THE GAME COULD DISCHARGE STATIC ELECTRICITY THROUGH THE GAME CIRCUITRY, WHICH COULD CAUSE DAMAGE.

2. Make sure the game is level after installation. It is necessary to make sure the game is level for safety concerns.
3. Check that the A.C. voltage rating on the back of the game matches the A.C. voltage of your location.

THE POWER SUPPLY IS NOT VOLTAGE ADJUSTABLE. TO OPERATE THE GAME AT VOLTAGES OTHER THAN THOSE IT WAS DESIGNED FOR. PLEASE CONTACT OUR SERVICE DEPARTMENT FOR VOLTAGE CONVERSION INFORMATION.

WARNING

DO NOT remove any of the components on the main board (e.g. compact flash and eproms) while the game is powered on. This may cause permanent damage to the parts and the main board. Removing any main board component part while powered on will void the warranty.

NOTE: THIS GAME IS INTENDED FOR INDOOR USE ONLY.
ON THE BACK PANEL OF THE GAME: WARNING: SHOCK HAZARD - DO NOT OPEN. REFER SERVICING TO SERVICE PERSONNEL.

GAME SETUP AND FEATURES

Player Controls

To begin the game, insert the proper number of credits, and squeeze the Peanut Launcher button. There are two Peanut Launchers, one for the left player and one for the right player.

Playing the Game

The objective of the game is to feed as many animals as possible within the game time in order to accumulate points and tickets. Animals appear from all sides of the screen.

There are bonus items such as: red balloons – awards Double Points, blue balloons – awards more time, Golden Roo – awards additional Bonus Points.

Initial Game Setup

The game is setup at the factory with the recommended factory settings. The following outlines the important adjustments an operator may adjust during initial game setup. For more detailed instructions on setting these adjustments, see Chapter 3.

Coins

Set the number of credits required to start the game. Also set the number of credits for each coin inserted in coin mechanism 1 and coin mechanism 2. These settings are adjusted in the COINAGE ADJUSTMENTS menu.

Tickets

Setup the points per ticket, minimum tickets paid, maximum tickets paid and ticket threshold. Also, setup whether tickets should be dispensed while playing or at the end of the game. These settings are adjusted in the TICKET ADJUSTMENTS menu.

Time Limit

Set the amount of game time for each start. These settings are adjusted in the GAME ADJUSTMENTS menu.

Points Per Ticket

Set the number of points required to earn one ticket.

Control Switches

The control switches are inside the front coin door.

Volume Up

Press the volume up button to increase the volume in the game and the attract mode. Pressing this button when playing the game will increase the game volume. Pressing this button when the game is in the attract mode will increase the attract mode volume.

Volume Down

Press the volume down button to decrease the volume in the game and the attract mode. Pressing this button when playing the game will decrease the game volume. Pressing this button when the game is in the attract mode will decrease the attract mode volume.

Diagnostics Button

Press this button to go into the diagnostics MAIN MENU.

Coin Meters

The game has two mechanical meters. The left meter will be incremented by 1 each time a coin is dropped into the coin mechanisms. The right meter will be incremented by 1 each time a ticket is dispensed.

GAME SETUP AND FEATURES

Game Setup Location

The sizes shown on the diagram below will help you determine the area required for your game, and where you might want the game to be placed.

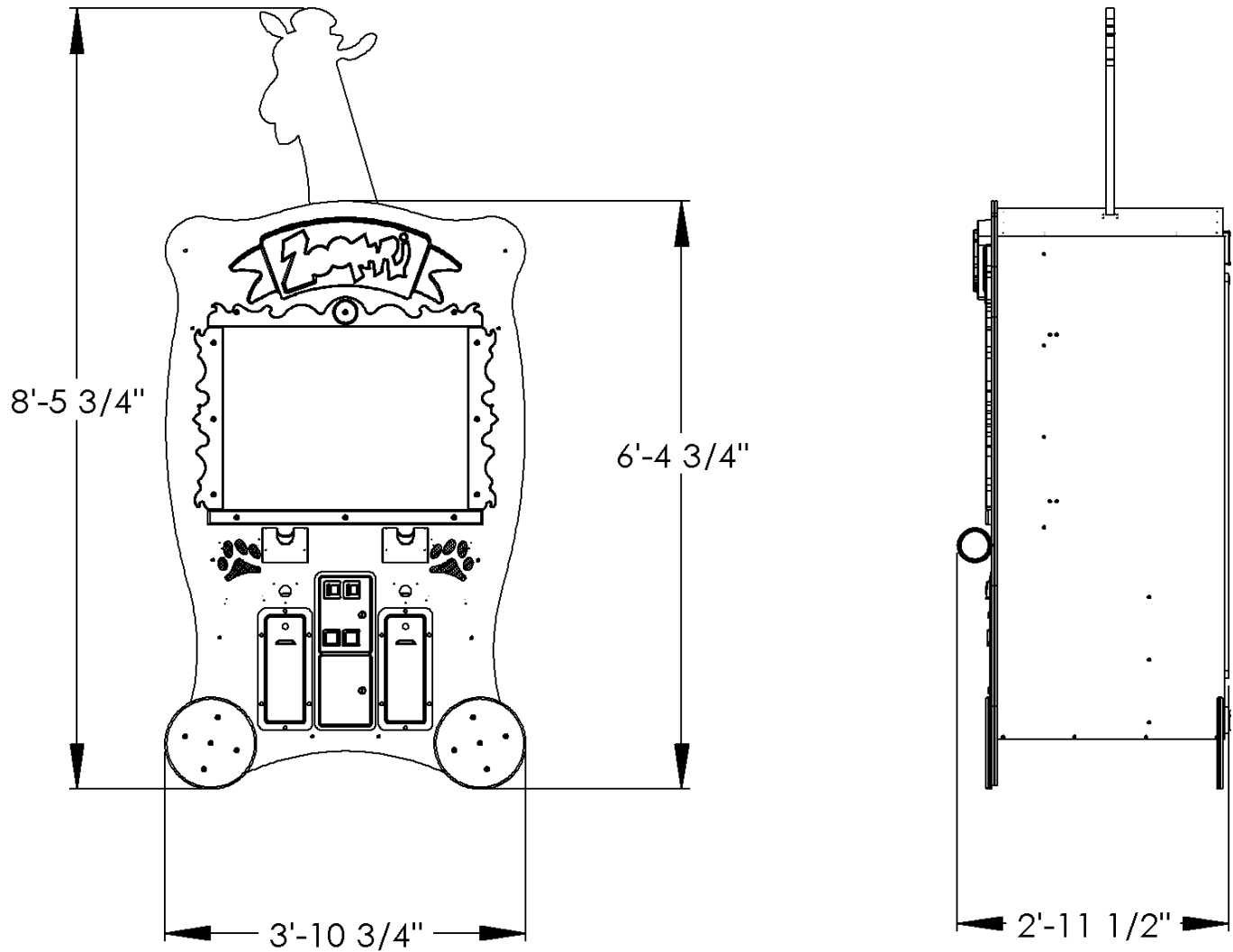

DIAGNOSTIC, ADJUSTMENT AND AUDIT MENU SYSTEM

Menu System

The game's menu system is a series of on screen menus that allow the operator to setup and adjust the settings. Each menu item leads to another menu, a list of data or provides the ability to modify the adjustment.

Starting the Menu System

Press the Diagnostics control switch inside the coin door to access the on screen menu system.

Navigating the Menu

Use the following buttons to navigate the menu system:

Volume Up button to move the cursor up.

Volume Down button to move the cursor down.

Diagnostic button to select.

Once an item has been selected, use the Volume Up/Volume Down button to change the settings. Once an item has been changed, press the Diagnostic button to save the desired setting.

Main Menu

All system tests, audits and game adjustments are accessible from the MAIN MENU.

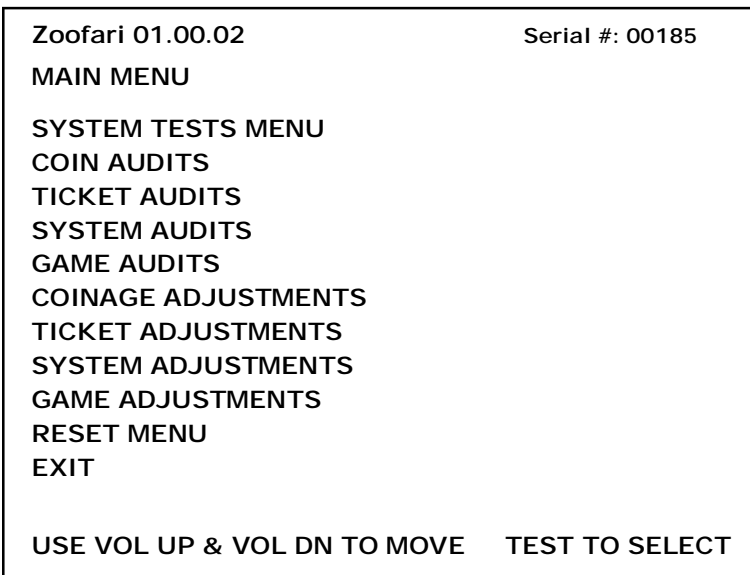

DIAGNOSTIC, ADJUSTMENT AND AUDIT MENU SYSTEM

Main Menu

Select SYSTEMS TEST at the MAIN MENU.

Zoofari 01.00.02	Serial #: 00185
SYSTEM TESTS MENU	
GUN TEST & CALIBRATE	
SWITCH INPUT TEST	
VIDEO SCREEN TESTS	
SOUND TEST	
MAIN MENU	
USE VOL UP & VOL DN TO MOVE TEST TO SELECT	

Gun Test & Calibrate - Select GUN TEST & CALIBRATE to calibrate the gun with the target on the screen.

Switch Input Test - Select SWITCH INPUT TEST to manually test all of the switch inputs. When in this screen, activate the start button, select button, test button, volume up, volume down, ticket sensor 1, ticket sensor 2, coin 1, coin 2, game control pad 1 and game control pad 2 to determine if the game recognizes input from each.

Video Screen Tests - Select VIDEO SCREEN TESTS to test the following: Screen Color, Screen Size, Red Color, Green Color, Blue Color, and White Color.

Sound Test - Select SOUND TEST to test various game sounds and songs.

Zoofari 01.00.02	Serial #: 00185
VIDEO SCREEN TESTS	
COLOR ADJUSTMENT	
RED SCREEN	
GREEN SCREEN	
BLUE SCREEN	
WHITE SCREEN	
EXIT	
USE VOL UP & VOL DN TO MOVE TEST TO SELECT	

Color Adjustment – Displays multiple colors for screen color adjustment.

Screen Size Adjustment – Displays grid for screen size adjustments.

Red Screen – Displays full red for screen color adjustments.

Green Screen - Displays full green for screen color adjustments.

Blue Screen - Displays full blue for screen color adjustments.

White Screen - Displays full white for screen color adjustments.

DIAGNOSTIC, ADJUSTMENT AND AUDIT MENU SYSTEM

View Coin Audits

Select VIEW COIN AUDITS at the MAIN MENU to view coin data about the game.

Zoofari 01.00.02	Serial #: 00185
COINAGE AUDITS	
COIN 1	0
COIN 2	0
PAID CREDITS	0
LIFETIME COIN COUNT	0
MAIN MENU	
USE VOL UP & VOL DN TO MOVE TEST TO SELECT	

Coin 1 – Number of coins inserted in coin mechanism 1.

Coin 2 – Number of coins inserted in coin mechanism 2.

DBV – Number of bills inserted in DBV mechanism.

Paid Credits – Number of coins inserted in all coin devices.

Lifetime Coin Count – Number of coins inserted in all coin devices since the game has been installed. This WILL NOT be reset by CLEAR COIN COUNTERS or RESTORE FACTORY SETTINGS from the UTILITIES menu.

View Ticket Audits

Select VIEW TICKET AUDITS at the MAIN MENU to view ticket data about the game.

Zoofari 01.00.02	Serial #: 00185
TICKET AUDITS	
TICKETS WON	0
AVERAGE TIX	0
TIX DISPENSED 1	0
TIX DISPENSED 2	0
HIGH TICKET	0
MAIN MENU	
USE VOL UP & VOL DN TO MOVE TEST TO SELECT	

Tickets Won – Total number of tickets won.

Average Tix – Average tickets dispensed per game.

Tix Dispensed 1 – Total tickets dispensed from dispenser 1.

Tix Dispensed 2 – Total tickets dispensed from dispenser 2.

High Ticket – Highest number of tickets won.

DIAGNOSTIC, ADJUSTMENT AND AUDIT MENU SYSTEM

View System Audits

Select VIEW SYSTEM AUDITS at the MAIN MENU to view data about the game.

Zoofari 01.00.02	Serial #: 00185
SYSTEM AUDITS	
UP TIME	0Y 0D 00:00:00
PLAY TIME	0Y 0D 00:00:00
PLAYER 1 STARTS	0
PLAYER 2 STARTS	0
MAIN MENU	
USE VOL UP & VOL DN TO MOVE TEST TO SELECT	

Up Time H:M:S - Total up time. Reported in Hours, Minutes and Seconds.

Play Time H:M:S - Total up time. Reported in Hours, Minutes and Seconds.

Player 1 Starts – Number of starts for Player 1.

Player 2 Starts – Number of starts for Player 2.

View Game Audits

Select VIEW GAME AUDITS at the MAIN MENU to view import data about the game.

NOTE: All Game Audits will be reset if you RESET AUDITS or RESTORE FACTORY SETTINGS from the UTILITIES menu.

Zoofari 01.00.02	Serial #: 00185
GAME AUDITS	
AVERAGE SCORE	0.00
HIGH SCORE	0
MAIN MENU	
USE VOL UP & VOL DN TO MOVE TEST TO SELECT	

Average Score – Average score per game played. Use this setting to help determine ticket settings from the TICKET UTILITIES menu.

High Score – Highest Score achieved.

DIAGNOSTIC, ADJUSTMENT AND AUDIT MENU SYSTEM

Coinage Adjustments

Select COINAGE ADJUSTMENTS at the MAIN MENU. Modify these coinage adjustments to change the price of the game.

Zoofari 01.00.02	Serial #: 00185
COINAGE ADJUSTMENTS	
COIN SLOT 1 UNITS	1
COIN SLOT 2 UNITS	1
CREDITS TO START	1
MAXIMUM CREDITS	OFF
FREE PLAY	OFF
MAIN MENU	
USE VOL UP & VOL DN TO MOVE TEST TO SELECT	

Coin Slot 1 Units – Set the number of credits received when a coin or token is inserted in coin mechanism 1. Set from 1 – 20 or “Off”.

Coin Slot 2 Units – Set the number of credits received when a coin or token is inserted in coin mechanism 2. Set from 1 – 20 or “Off”.

Credits to Start – Set the number of credits required to start a game. Set from 1 – 10.

Maximum Credits - Set the maximum of credits allowed. Set from 1 - 99 or “Off”.

Free Play – If set to ‘Yes’ the game is set on free play and no coins or credits will be required to play.

Ticket Adjustments

Select TICKET ADJUSTMENTS at the MAIN MENU. Modify these ticket adjustments to change the number of tickets dispensed by the game.

Zoofari 01.00.02	Serial #: 00185
TICKET ADJUSTMENTS	
TICKET DISPENSER	ON
TICKET MINIMUM	1
TICKET MAXIMUM	OFF
IDEAL PAYOUT	10
DISPENSE WHILE PLAYING	ON
MAIN MENU	
USE VOL UP & VOL DN TO MOVE TEST TO SELECT	

Tickets Dispenser – This setting turns the ticket dispenser on or off.

Tickets Minimum – This setting determines the minimum number of tickets to be dispensed for each game played. Set from 1 – 10. If the game does not have a ticket dispenser, set to 0.

Tickets Maximum – This setting determines the maximum number of tickets to be dispensed for each game played. Set from 1 – 100 or “Off”. If the game does not have a ticket dispenser, set to 0.

Ideal Payout - This setting determines the ideal ticket payout per game. Set from 0 - 100 or “Off”.

Dispense While Playing – Set to ‘Off’ to dispense tickets at the end of each game. Set to ‘On’ to dispense tickets as they are earned during game play.

DIAGNOSTIC, ADJUSTMENT AND AUDIT MENU SYSTEM

System Adjustments

Select SYSTEM ADJUSTMENTS at the MAIN MENU. Modify these values to change the mode and volume level of the game.

Zoofari 01.00.02	Serial #: 00185
SYSTEM ADJUSTMENTS	
ATTRACT SOUND	ON
MINIMUM VOLUME	0
MAIN MENU	
Play sounds in attract mode	
USE VOL UP & VOL DN TO MOVE TEST TO SELECT	

Attract Sound – Set to “On” to have attract mode play while game is idle. Set to “Off” if no attract mode is desired. Set to “Occasionally” if attract mode is desired some of the time.

Minimum Volume – Minimum volume setting for the game. Set from 0 – 255. The higher the setting the higher the volume.

Game Adjustments

Select GAME ADJUSTMENTS at the MAIN MENU. Modify these game adjustments to change the way the game functions.

Zoofari 01.00.02	Serial #: 00185
GAME ADJUSTMENTS	
GAME TIME	30
BONUS TIME	10
MAXIMUM ANIMALS	3
POINTS PER TICKET	100
PEANUT STYLE	ORANGE/GREEN
MAIN MENU	
Time is seconds of one play	
USE VOL UP & VOL DN TO MOVE TEST TO SELECT	

Game Time – Game Time. Minimum time = 1 seconds, Maximum = 60 seconds.

Bonus Time – Frequency of the Time Bonus coming out. Set from 1 - 30 seconds.

Maximum Animals - Maximum number of animals on the screen at one time. Set from 1 - 10.

Points Per Ticket - Number of points required to win one ticket. Set from 10 - 1000.

Peanut Style - Color of peanuts used to feed the animals. Choose from: ORANGE/GREEN, BLUE/YELLOW or CLASSIC.

DIAGNOSTIC, ADJUSTMENT AND AUDIT MENU SYSTEM

Reset Menu

Select RESET MENU at the MAIN MENU. Select these options to reset game audits.

Zoofari 01.00.02	Serial #: 00185
RESET MENU	
RESET CREDITS	
RESET TICKETS	
RESET AUDITS	
RESET ADJUSTMENTS	
FACTORY RESET	
MAIN MENU	
USE VOL UP & VOL DN TO MOVE TEST TO SELECT	

Reset Credits – Resets credits stored in the game.

Reset Tickets – Resets the number of tickets won.

Reset Audits – Resets all game audits.

Reset Adjustments – Resets all adjustments made to the game.

Factory Reset – Resets the game to factory defaults.

I.C.E. Parts/Service Dept.

Phone #: (716) - 759 – 0360

Fax #: (716) – 759 – 0884

NORMAL BUSINESS HOURS ARE:

MONDAY - FRIDAY, 9:00 AM TO 6:00 PM EST

TROUBLESHOOTING

Troubleshooting

CAUTION

This game uses complex electronic components that are very sensitive to static electricity. Observe precautions below before handling these electronics. Failure to do so may void the warranty and damage electronic assemblies.

Before servicing electronics, turn off AC power to the game. Wait for capacitors to discharge.

DO NOT remove any of the components on the main board (e.g. compact flash and eproms) while the game is powered on. This may cause permanent damage to the parts and the main board.

Before touching or handling electronic assemblies, discharge static electricity on your body. To discharge this static, begin by connecting the line cord to a grounded outlet. Don't turn on the game. Next, touch the safety ground stud of the power supply chassis.

Store electronic assemblies in an anti-static area. Use anti-static bags to store or transport the game circuit boards.

Don't remove or connect electronic assemblies when cabinet power is on. Otherwise, you'll damage electronic assemblies and void the game's warranty.

After you complete maintenance or service, replace ground wires, shields, safety covers and install and tighten ground and mounting screw.

Video game monitors generate and store potentially high voltages. Avoid touching any part of the monitor until power has been off for some time. A picture tube can maintain a hazardous charge for up to several days. Only qualified technicians should service monitors.

Game Is Non-Functional

1.	Verify that the game power switch is turned on.
2.	Verify that earth ground is properly connected and all exposed metal points are properly grounded.
3.	Verify that the line cord connector is firmly and correctly seated into the power entry module of AC power chassis.
4.	Verify that correct AC line voltage is present at the outlet
5.	Verify that the JAMMA wire harness connector is firmly and properly seated to the mating JAMMA PCB edge connector. DO NOT remove or install JAMMA connector when power is turned on. Doing so will damage the CPU assembly and void the warranty.
6.	Verify that the DC power supply voltages at the game CPU assembly are set as follows. The following voltages should be set when the game CPU assembly is connected and the game is powered on. +5V: +4.9V - +5.1V /// +12V: +11.5V - +12.5V //// -5V:-4.75V - -5.25V
7.	Verify that the non-JAMMA connectors are attached at the proper location and are firmly seated.
8.	Verify that the game DIP switches are set properly.
9.	If game sounds can be heard but no picture is seen on the monitor, see monitor is non functional

TROUBLESHOOTING

Monitor Is Non-Functional

1.	Verify the cabinet has AC line voltage present at the monitor and has earth ground connected.
2.	Verify that the video is properly connected from the game boards output to the monitor input.
3.	Verify that the monitor remote adjustment board is properly installed and connected to the monitor chassis. Verify that brightness and contrast are set above their minimum levels.
4.	Check fuses on monitor chassis. Replace fuse or chassis as necessary.
5.	Verify that the game is using a low-res monitor.

Sound Is Non-Functional

1.	Verify the cabinet wiring is correct. Ensure that the speakers are properly connected to the audio wires from the JAMMA connector.
2.	Verify that the power is providing: +5V: +4.9V - +5.1V +12V: +11.5V - +12.5V -5V: -4.75V - -5.25V
3.	Verify that the above listed voltages are present at the correct JAMMA connector pins.
4.	Verify that the game volume has been turned up.

Game Controls Are Non-Functional

1.	Verify that the each individual switch is working by doing the SWITCH INPUT TEST under the SYSTEM TESTS MENU.
2.	Verify that the each individual signal wire for each switch is connected.

MAINTENANCE / REPAIR

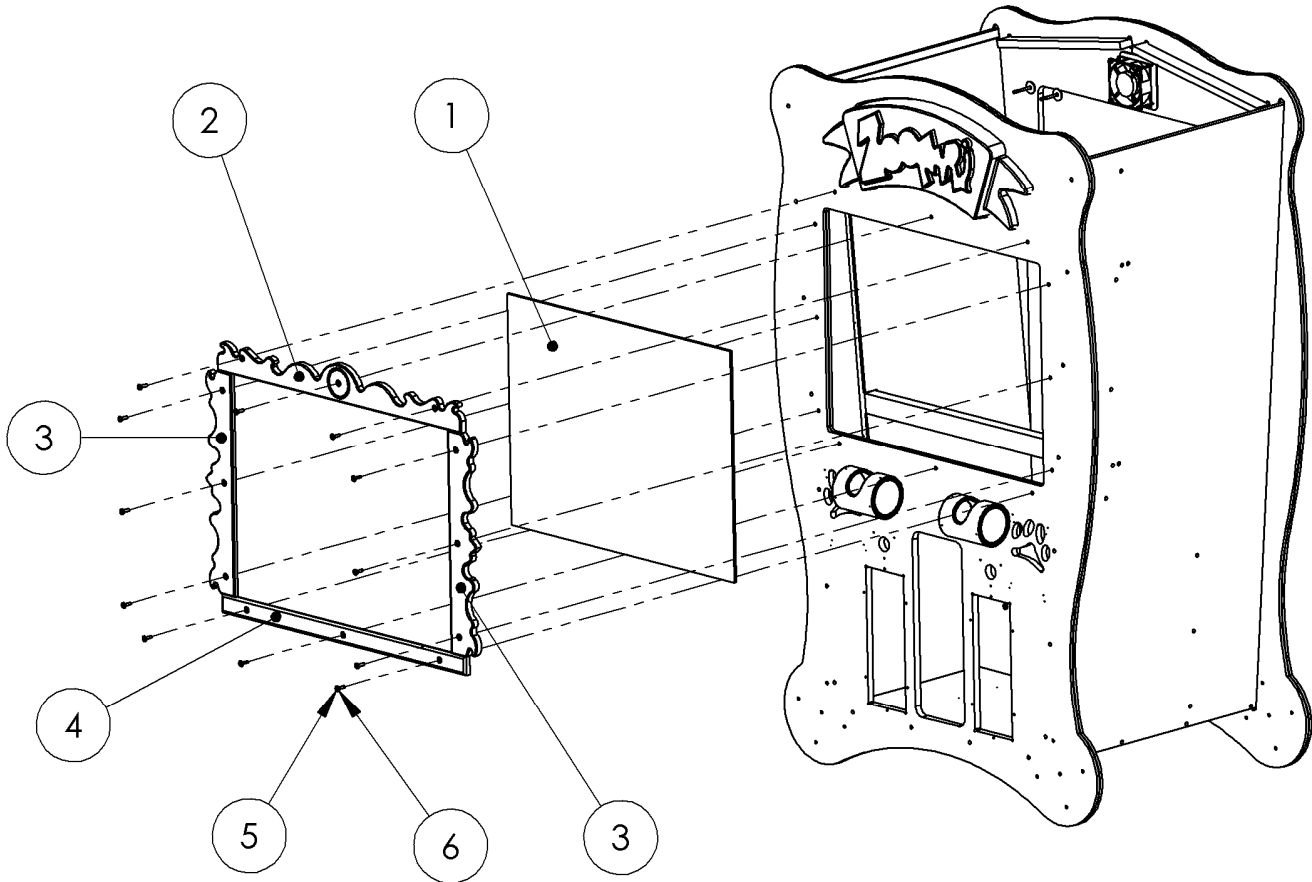

To Clean Glass and Monitor

1. Remove item no. 2.
2. Remove item no. 3.
3. Remove glass (item no. 1)
4. Assemble in reverse.

ITEM NO.	PART NO.	DESCRIPTION	QTY.
1	FZ3027	GLASS	1
2	FZ3032	FRAME TOP	1
3	FZ3031	FRAME SIDE	2
4	FZ3030	FRAME BOTTOM	1
5	6281	1/4-20 X 1" LG. BHCS ZINC	12
6	6020	#10 FLAT WASHER ZINC	12

MAINTENANCE / REPAIR

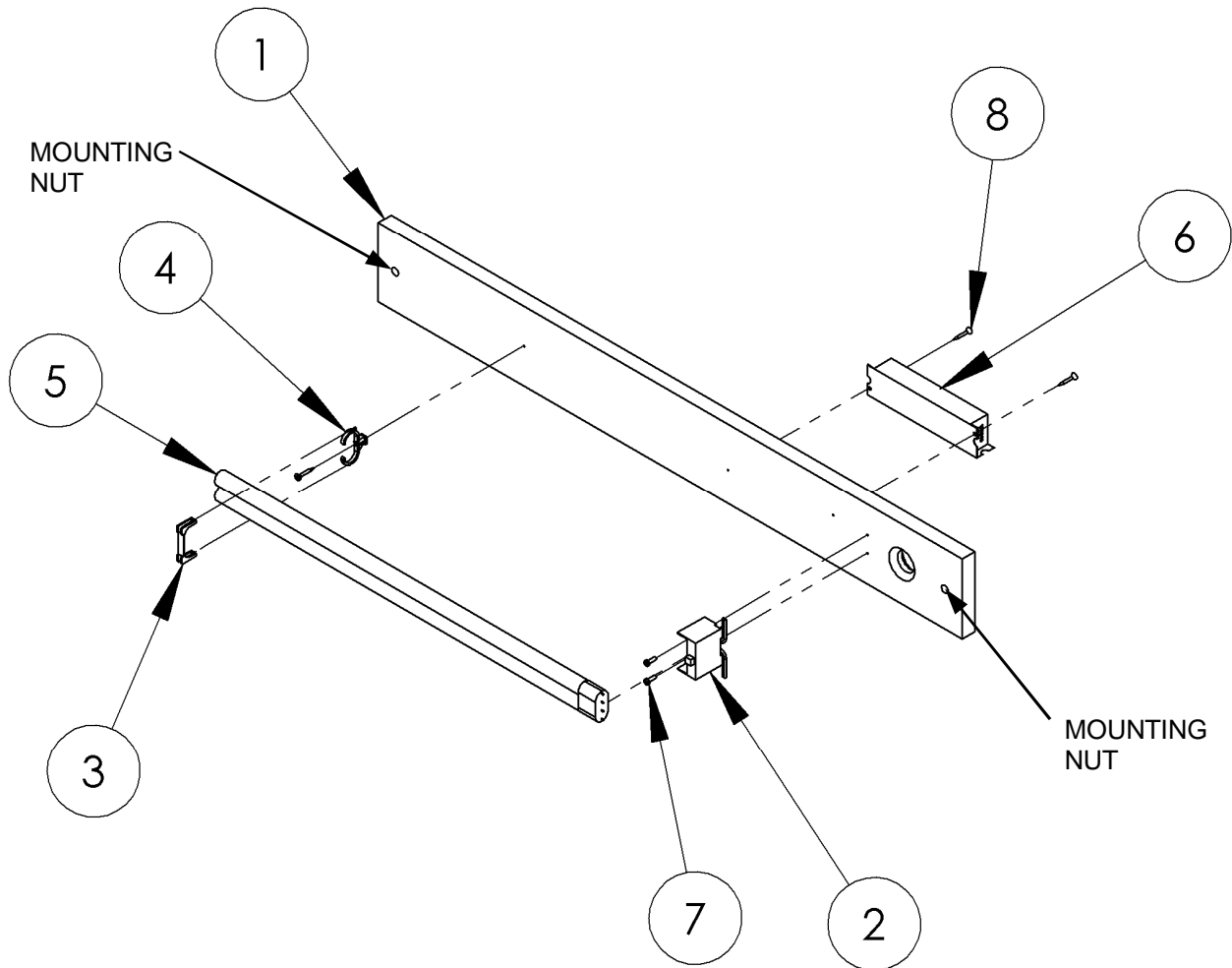

To Replace Light Bulb In Marquee

1. Remove back panel of cabinet.
2. Locate above light fixture assembly.
3. Remove 2 mounting nuts located in above diagram.
4. Remove assembly and replace bulb.
5. Assemble in reverse.

ITEM NO.	PART NO.	DESCRIPTION	QTY.
1	FZ3068	PANEL (LIGHT BOARD)	1
2	BW250	BULB SOCKET	1
3	BW2017	BULB PLASTIC CLIP	1
4	BW2018	BULB PLASTIC SUPPORT	1
5	8312	BULB PL-L	1
6	CS8449X	BALLAST ASSEMBLY	1
7	6071	#6 x 1/2 SELF-TAP (BLACK)	2
8	6019	#6 DRYWALL SCREW 1"	3

MAINTENANCE / REPAIR

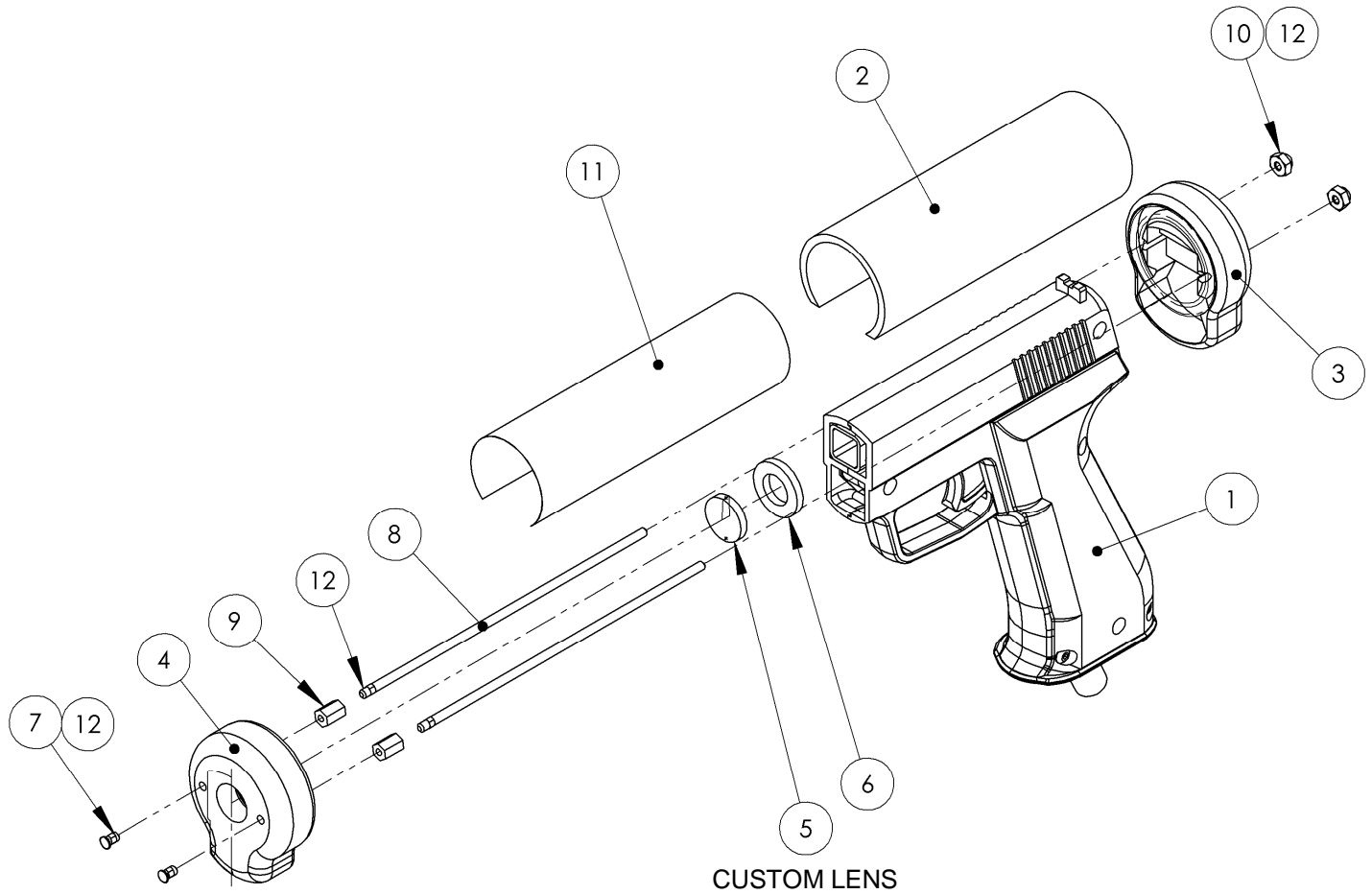

ITEM NO.	PART NO.	DESCRIPTION	QTY.
1	FZ2011	SHOOTER HOUSING (YELLOW)	1
2	FZ3010	SHOOTER TUBE	1
3	FZ3011	SHOOTER BUTT	1
4	FZ3016	SHOOTER POINT	1
5	PT2013	LENS (GUN) 96-0068-00	1
6	6251	NYLON WASHER	1
7	6269	6-32 x 1/4 PEM STUD	2
8	FZ1050	6-32 THREADED ROD	2
9	640	6-32 x 3/8 HH SPACER (METAL)	2
10	6324	6-32 ACORN NUT	2
11	FZ7011	DECAL, GUN BARREL	1
12		THREAD LOCK	A/R

MAINTENANCE /REPAIR

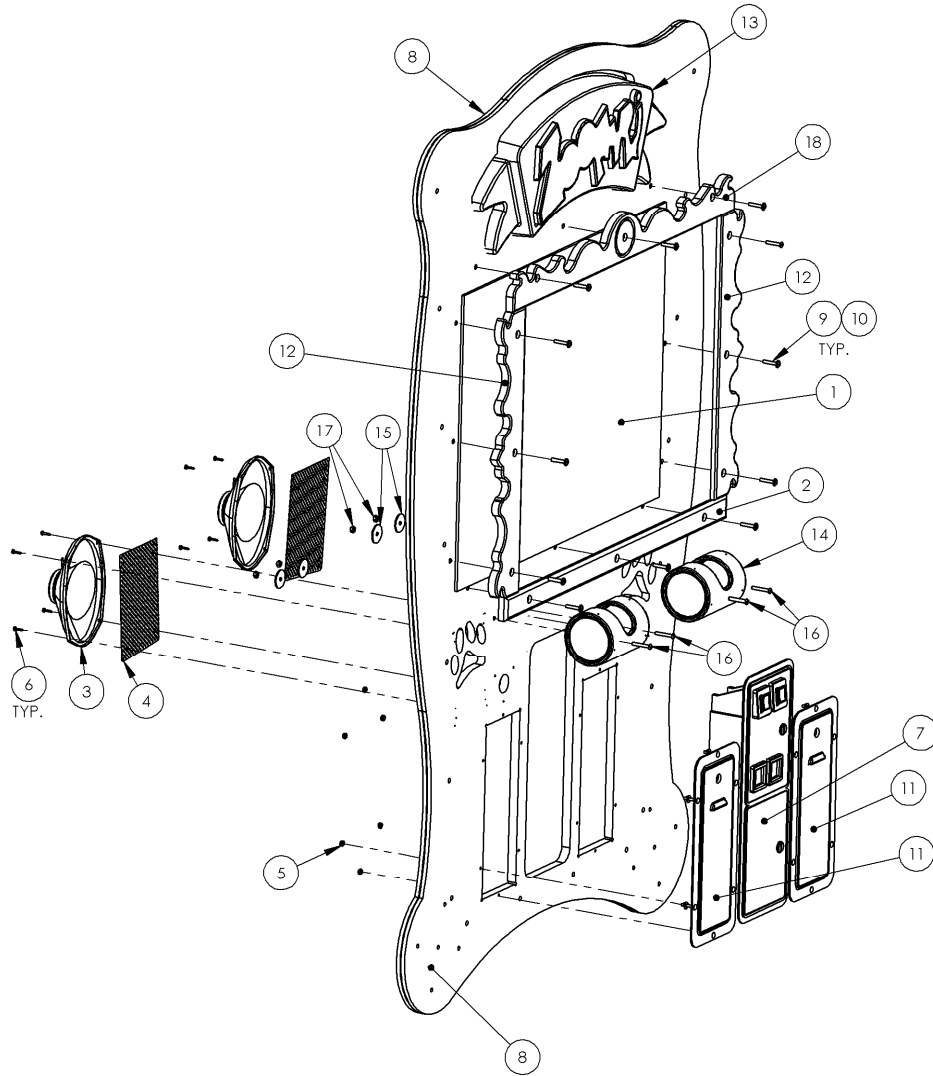

ITEM NO.	PART NO.	DESCRIPTION	QTY.
1	FZ3027	GLASS	1
2	FZ3030	FRAME BOTTOM	1
3	FG2007	6 X 9 SPEAKER (SHIELDED)	2
4	FZ1019	SPEAKER GRILL	2
5	6040	10-24 KEP NUT	12
6	655	#8 X 3/4" SQ. DRIVE SCREW	8
7	5001	COIN DOOR SET	1
8	FZ3050X	CABINET FRONT ASSEMBLY	1
9	6281	1/4-20 X 1.5" LG. BHCS ZINC	12

ITEM NO.	PART NO.	DESCRIPTION	QTY.
10	6020	#10 FLAT WASHER ZINC	12
11	5008	TICKET DOOR (HAPP)	2
12	FZ3031	FRAME SIDE	2
13	FZ7027F	MARQUEE	1
14	FZ3071	PEANUT BARREL ASSEMBLY	2
15	6070	1/4 X 1-1/2" X .090 F-WASHER	4
16	6220	1/4-20 X 1 3/4" BSHCS (BLACK)	4
17	PC60604	1/4-20 NYLOCK NUT	4
18	FZ3032	FRAME TOP	1

PARTS LISTINGS

Mechanical Parts

211	Low Ticket Switch
1024	Ticket Bin
5001	Coin Door
5008	Ticket Door
FZ2011	Gun - No Recoil - Yellow
FZ3000	Wheel (Back Left)
FZ3001	Wheel (Front)
FZ3010	Shooter Tube
FZ3027	Monitor Glass
FZ3037	Wheel (Back Right)
FZ3071	Barrel & End Cap Assembly
FZ7027	Marquee
PT2011X	Gun - No Recoil - Blue

Electrical Parts

8312	PL-L Bulb
8716	Flash Card - Compact
CS8449X	Ballast (WH-3)
DD2364X	Fan
FG2007	Speaker 6" X 9"
MON29CF	Monitor - 29" Flat Screen
RN2034FZX	PCB (Main)
WA2010	Power Supply

Graphics and Decals

FZ7000	Decal - Gorilla Side
FX7001	Decal - Cartouche
FZ7002	Decal - Side (Feed The Animals.....)
FZ7003	Decal - Cabinet Front
FZ7004	Decal - Wheels
FZ7005	Decal - Monitor Bezel
FZ7006	Decal - Side (Lower Strip)
FZ7008	Decal - Monitor Peanuts
FZ7009	Decal - Barrel
FZ7010	Decal - Barrel Peanuts
FZ7013	Decal - Instructions
FZ7024	Decal - ICE Logo
FZ7025	Decal - Giraffe Head - Front
FZ7026	Decal - Giraffe Head - Rear

1 2 3 4

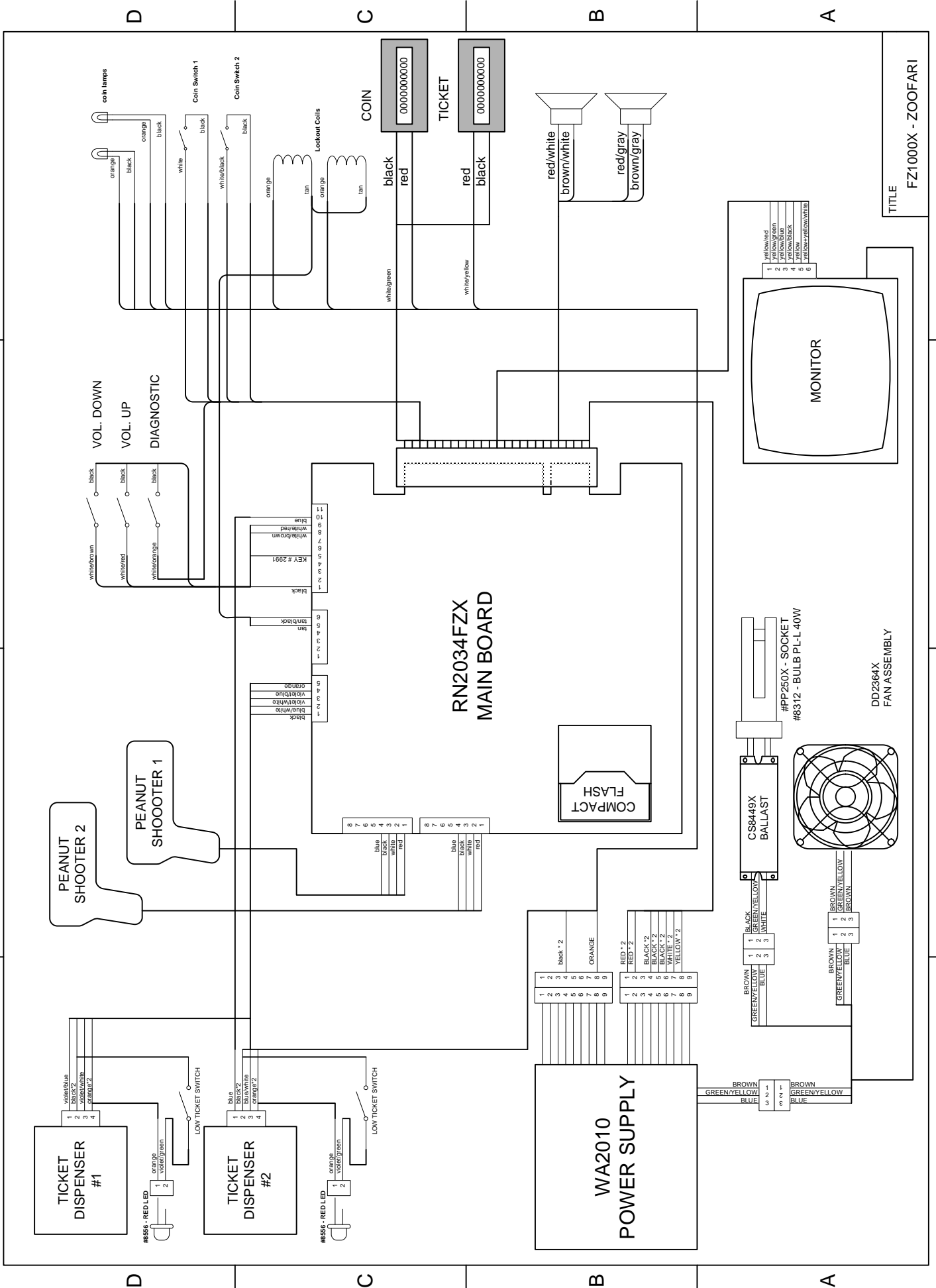

TITLE FZ1000X - ZOOFARI

1 2 3 4

PINOUT FOR CARDEDGE CONNECTOR

COMPONENT SIDE		SOLDER SIDE	
Ground	1	BLACK	Ground
Ground	2	BLACK	Ground
+ 5 Volts	3	RED	+ 5 Volts
+ 5 Volts	4	RED	+ 5 Volts
- 5 Volts	5	WHITE	- 5 Volts
+ 12 Volts	6	YELLOW	+ 12 Volts
KEY	7	KEY	KEY
Coin	8	white/green	Ticket
NC	9	Dummy Pin	NC
Left Speaker +	10	red/gray	Left Speaker -
Right Speaker +	11	red/white	Right Speaker -
Red Video	12	yellow/red	Green Video
Blue Video	13	yellow/blue	Composite Sync
Video Ground	14	yellow/black	Service
Diagnostics	15	white/orange	Tilt
Coin 1	16	white	Coin 2
Player 1 Start	17	Dummy Pin	Player 2 Start
Player 1 Select	18	Dummy Pin	Player 2 Up
Player 1 Down	19	Dummy Pin	Player 2 Down
Player 1 Left	20	Dummy Pin	Player 2 Left
Player 1 Right	21	Dummy Pin	Player 2 Right
Player 1 Button 1	22	Dummy Pin	Player 2 Button 1
Player 1 Button 2	23	Dummy Pin	Player 2 Button 2
Player 1 Button 3	24	Dummy Pin	Player 2 Button 3
Player 1 Button 4	25	Dummy Pin	Player 2 Button 4
NC	26	Dummy Pin	NC
Ground	27	black	Ground
Ground	28	BLACK	Ground
			A
			B
			C
			D
			E
			F
			H
			J
			K
			L
			M
			N
			P
			R
			S
			T
			U
			V
			W
			X
			Y
			Z
			a
			b
			c
			d
			e
			f

ZOO FARI PIN OUT FZ2052X - HARNESS (MAIN)

WARRANTY

I.C.E warrants all components in the **ZOOFARI™** game to be free of defects in materials and workmanship for a period of ninety days from the date of purchase.

This warranty does not cover items damaged due to normal wear and tear, subjected to abuse, improperly assembled by the end user, modified, repaired, or operated in a fashion other than that described in the service manual.

If your **ZOOFARI™** game fails to conform to the above-mentioned warranty, I.C.E.'s sole responsibility shall be at its option to repair or replace any defective component with a new or remanufactured component of equal to or greater O.E.M. specification.

I.C.E. will assume no liability whatsoever, for costs associated with labor to replace defective parts, or travel time associated therein.

I.C.E.'s obligation will be to ship free of charge, replacement parts by U.P.S. Ground, U.S. mail, or other comparable shipping means. Any express mail or overnight shipping expense is at the cost of the purchaser.

Products will be covered under warranty only when:

- The serial number of the game with the defective parts is given. A tech number has been issued by an I.C.E. technical representative.
- The serial number of the defective part, if applicable, is given.
- Defective parts are returned to I.C.E., shipping pre-paid, in a timely fashion, if requested by I.C.E.
- A copy of the sales receipt is available as proof of purchase upon request of I.C.E.

I.C.E. distributors are independent, privately owned and operated. In their judgment, they may sell parts or accessories other than those manufactured by I.C.E. We cannot be responsible for the quality, suitability, or safety of any non-I.C.E. part, or any modification, including labor, which is performed by such a distributor.



WARRANTY

ICE Inc warrants that all of its products will be free from defects in material and workmanship.

When placing a warranty request, please be prepared to provide the following information:

- Serial Number of Game or Bill of Sale
- Machine Type
- A Detailed Description of the Equipment Fault Symptoms

ICE product, including Cromptons, Sam's Billiards, Uniana and Bell Fruit is warranted as follows:

- 180 days on the Main PCB and Computers
- 180 days on Motors
- 90 days on all other components (i.e. DBV's, Ticket Dispensers, etc)
- 30 days on repaired items
- 3 years on all Crane Harnessing
- 9 Months on Printers

ICE Inc shall not be obligated to furnish a warranty request under the following conditions:

- Equipment has been subjected to unwarranted stress through abuse or neglect
- Equipment has been damaged as a result of arbitrary repair/modification attempts
- Equipment that has failed through normal wear and tear

ICE Inc will assume no liability whatsoever for costs associated with labor to replace defective parts or travel time associated therein.

All defective warranty covered components will be replaced with new or factory refurbished components equal to OEM specifications. ICE Inc will cover all UPS ground, or comparable shipping means, freight costs during the warranty period. Expedited shipments are available for an additional charge.

Defective parts are returned to ICE Inc, at the customer's expense, in a timely fashion.

ICE distributors are independent, privately owned and operated. In their judgment, they may sell parts and/or accessories other than those manufactured by ICE Inc. We cannot be responsible for the quality, suitability or safety of any non-ICE part, modification (including labor) that is performed by such a distributor.

I.C.E. Parts/Service Dept.
Innovative Concepts in Entertainment
10123 Main St.
Clarence, NY 14031
Phone #: (716) - 759 - 0360
Fax #: (716) - 759 - 0884