

GRAND

CHAMPION™

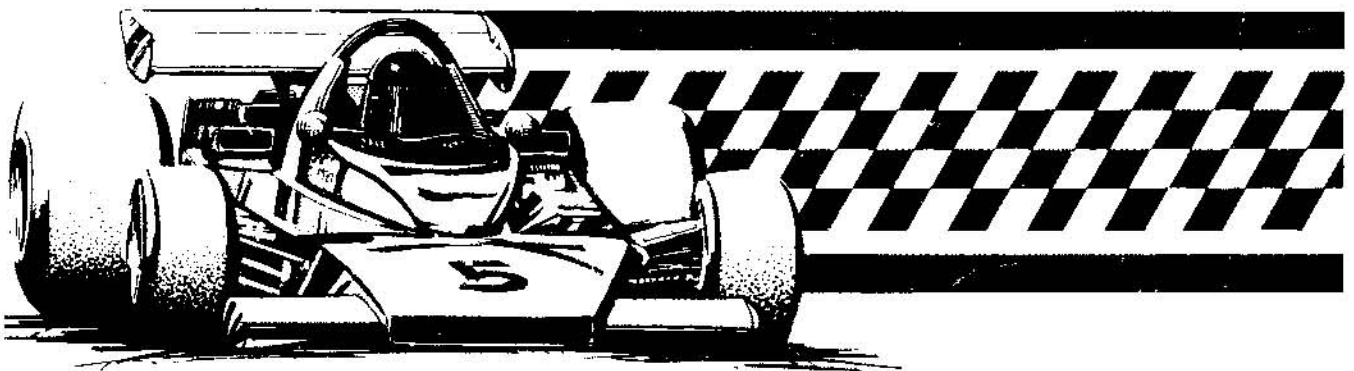

© 1981
Trade Marks of Taito America Corporation

72-00012-001

GRAND CHAMPION™ UPRIGHT

TABLE OF CONTENTS

1. GRAND CHAMPION™ UPRIGHT GAME SET-UP	Page 2	3. ILLUSTRATIONS AND PART LISTS (CONT.)	
A. Introduction	2	Figure 17 Shift Lever Assembly	18
B. Pre-Game Installation	2	Figure 18 Time & Score Board Component Layout	20
C. Game Inspection	2	Figure 19 CPU PC Board Component Layout	22
D. Game Installation	2	Figure 20 Game PC Board Component Layout	24
E. Option Switches and Volume Control Settings	2	Figure 21 Sound PC Board Component Layout	27
2. MAINTENANCE	3	Figure 22 CPU Board Schematic 1 of 7	31
A. Cleaning	3	Figure 23 CPU Board Schematic 2 of 7	32
B. Fuse Replacement	3	Figure 24 CPU Board Schematic 3 of 7	33
C. Video Monitor Removal	4	Figure 25 CPU Board Schematic 4 of 7	34
D. Video Monitor Adjustments (Separate Manual)	4	Figure 26 CPU Board Schematic 5 of 7	35
E. Fluorescent Bulb Replacement	4	Figure 27 CPU Board Schematic 6 of 7	36
F. Printed Circuit Board Replacement	5	Figure 28 CPU Board Schematic 7 of 7	37
3. ILLUSTRATIONS AND PART LISTS		Figure 29 Game Board Schematic 1 of 10	38
Figure 1 Option Switches	2	Figure 30 Game Board Schematic 2 of 10	39
Figure 2 Option Switch Location	2	Figure 31 Game Board Schematic 3 of 10	40
Figure 3 Volume Control	3	Figure 32 Game Board Schematic 4 of 10	41
Figure 4 Volume Control Location	3	Figure 33 Game Board Schematic 5 of 10	42
Figure 5 Service Switch High Score Reset	3	Figure 34 Game Board Schematic 6 of 10	43
Figure 6 Cover Glass Removal And Dash Panel Installation	3	Figure 35 Game Board Schematic 7 of 10	44
Figure 7 Fuse Replacement	3	Figure 36 Game Board Schematic 8 of 10	45
Figure 8 Power Supply	4	Figure 37 Game Board Schematic 9 of 10	46
Figure 9 Video Monitor Removal	4	Figure 38 Game Board Schematic 10 of 10	47
Figure 10 P.C.B. Mounting Assembly	5	Figure 39 Sound Board Schematic 1 of 5	48
Figure 11 Cabinet Assembly (Front View)	6	Figure 40 Sound Board Schematic 2 of 5	49
Figure 12 Cabinet Assembly (Rear View)	8	Figure 41 Sound Board Schematic 3 of 5	50
Figure 13 Coin Door & Front Door Assembly	10	Figure 42 Sound Board Schematic 4 of 5	51
Figure 14 Dash Panel	12	Figure 43 Sound Board Schematic 5 of 5	52
Figure 15 Accelerator Assembly	14	Figure 44 Time & Score Board 1 of 2	53
Figure 16 Steering Assembly	16	Figure 45 Time & Score Board 2 of 2	54
		Figure 46 Wiring Diagram	55

"GRAND CHAMPION"™ UPRIGHT

1. GAME SET-UP

A. INTRODUCTION

"GRAND CHAMPION"™ Upright Driving game Manufactured by Taito America Corporation and designed for one or two players.

The object of the game is to avoid the opposing cars. The player has to drive through Dark Tunnels, Rain, Lightning, Sleet, Snow, and a Track that suddenly divides to get to the Finish Line first.

"GRAND CHAMPION"™ has a Radar Feature which enables the Player to see his position relative to the other cars.

A Rank Feature is also provided which shows the Players numerical rank all through the Race.

The Speech Feature enhances the game play.

B. PRE-GAME INSTALLATION

"Grand Champion"™ Upright game is shipped with the Dash Panel separate. To Install the Dash Panel follow the Instructions lists in Section 1 Cover Glass Removal & Dash Panel Installation.

C. GAME INSPECTION

TAITO AMERICA'S CORPORATION'S "GRAND CHAMPION"™ Upright game is shipped with the Dash Panel separate. After completing the installation of the Dash Panel (Section 1) a careful visual inspection should be made to insure your game is in perfect condition. Please verify the following before turning the game on.

- * Check the exterior of the game for shipping damage, chips, dents and broken parts.
- * Open the Service Door and examine the following:
 - * Plug-in connectors to make sure they are firmly seated.
 - * Speaker.
 - * Player controls, Steering Wheel and Accelerator.
 - * Printed circuit boards making sure there is no damage to the components.
 - * Check for loose foreign objects, especially metal objects which may cause electrical problems.
 - * Fuses, making sure they are firmly seated in the holders.
 - * Coin Mechanisms

The Video Monitor is properly adjusted before shipping. If there are any adjustments necessary refer to our Video Monitor Manual (72-00003-001).

If problems occur or technical assistance is required, contact our Customer Service Department HOT LINE Toll Free 800-323-0666 (except Illinois). Illinois phone 312 981-1000 X215.

POWER REQUIREMENTS

TAITO AMERICA CORPORATION'S "GRAND CHAMPION"™ Upright game is shipped ready for operation at 120VAC, 60Hz with a power consumption of approximately 250 Watts.

CAUTION

For safe operation it is recommended the cabinet be grounded. This game is equipped with a three conductor power cable. The third conductor is the ground conductor and when the cable is plugged into an appropriate receptable, the game is grounded. The offset pin on the power cable's three-prong connector is the ground connection.

LOCATION SPACE REQUIREMENTS

Depth - 35" (87.5cm)
 Width - 24" (61cm)
 Height - 68" (171cm)
 Weight - 300 lbs.
 (Packaged Weight)

D. GAME INSTALLATION

The following precautions should be followed when installing the game.

- * Avoid rough handling of the game, the picture tube is fragile.
- * Install the game on a level surface.
- * Avoid installing the game where it may receive excessive sunlight or heat, to prevent the game from rising internal temperature.
- * Do not install in a damp dusty location.
- * For a short time after connecting the power to the game, the picture may be temporarily distorted.

E. OPTION SWITCHES AND VOLUME CONTROL SETTINGS

TAITO AMERICA CORPORATION'S "GRAND CHAMPION"™ Upright game provides the following option switches. See Figure 1 and 2. These Switches can be found on the CPU Board (88100).

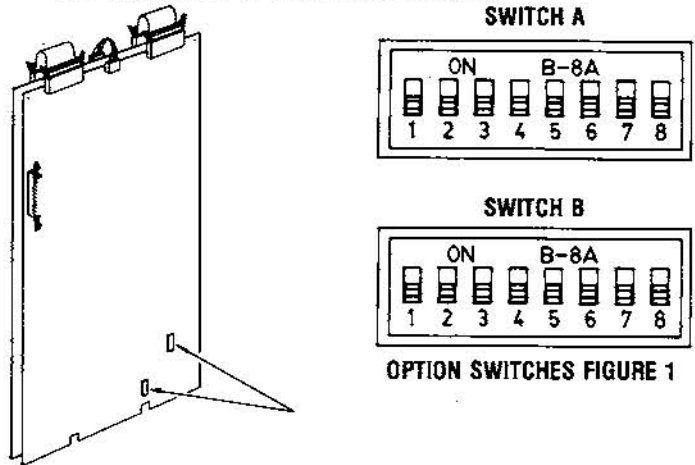

OPTION SWITCH LOCATION FIGURE 2

DIP SWITCH (A) is used for adjusting the play pricing listed below.

PLAY PRICING	#1 COIN SLOT (LEFT)				#2 COIN SLOT (RIGHT)			
	1	2	3	4	5	6	7	8
1 Coin - 1 Play	ON	ON	ON	ON	ON	ON	ON	ON
1 Coin - 2 Plays	OFF	ON	ON	ON	OFF	ON	ON	ON
1 Coin - 3 Plays	ON	OFF	ON	ON	ON	OFF	ON	ON
1 Coin - 4 Plays	OFF	OFF	ON	ON	OFF	OFF	ON	ON
1 Coin - 5 Plays	ON	ON	OFF	ON	ON	ON	OFF	ON
1 Coin - 6 Plays	OFF	ON	OFF	ON	OFF	ON	OFF	ON
1 Coin - 7 Plays	ON	OFF	OFF	ON	ON	OFF	OFF	ON
1 Coin - 8 Plays	OFF	OFF	OFF	ON	OFF	OFF	OFF	ON
2 Coins - 1 Play	ON	ON	ON	OFF	ON	ON	ON	OFF
3 Coins - 1 Play	OFF	ON	ON	OFF	OFF	ON	ON	OFF
4 Coins - 1 Play	ON	OFF	ON	OFF	ON	OFF	ON	OFF
5 Coins - 1 Play	OFF	OFF	ON	OFF	OFF	OFF	ON	OFF
6 Coins - 1 Play	ON	ON	OFF	OFF	ON	ON	OFF	OFF
7 Coins - 1 Play	OFF	ON	OFF	OFF	OFF	OFF	OFF	ON
8 Coins - 1 Play	ON	OFF	OFF	OFF	ON	OFF	OFF	OFF
9 Coins - 1 Play	OFF	OFF	OFF	OFF	OFF	OFF	OFF	OFF

NOTE: Two coin input signals from the above #1 and #2 coin slots will increase credits independently. For instance, no credit is made, when each one coin is inserted into the above #1 and #2 coin slots in case of 2 coins - 1 Play setting.

DIP SWITCH B IS USED FOR THE FOLLOWING

Switches 1 and 2 are used for ranking for the next free play. If the player is ranked at the order shown in the right column, he is given an extra free race.

RACE	SWITCHES	
	1	2
4th	ON	ON
5th	OFF	ON
6th	ON	OFF
7th	OFF	OFF

These Switches are factory set for the 5th race.

Switch 3 is not used and should remain in the OFF position.

Switch 4 is used for the RAM test.

ON	No Test
OFF	Test

Switch 5 is used for the COIN SYSTEM.

1 WAY	ON
2 WAY	OFF

Switch 6 is used for the display of "1981".

DISPLAY	ON
NO DISPLAY	OFF

Switch 7 is used for the Score Display.

NO DISPLAY	ON
DISPLAY	OFF

VOLUME CONTROL SETTING

The Volume Control Setting can be found on the CPU Board. Volume increases when the potentiometer is turned as indicated in Figure 3.

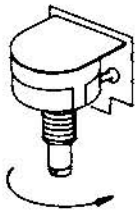

VOLUME CONTROL FIGURE 3

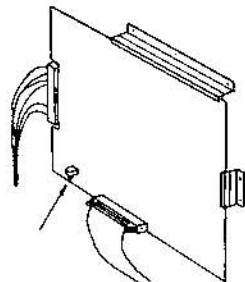

VOLUME CONTROL LOCATION FIGURE 4

SERVICE SWITCH & HIGH SCORE RESET

The Service Switch & High Score Reset Switch is located on the Coin Door Frame.

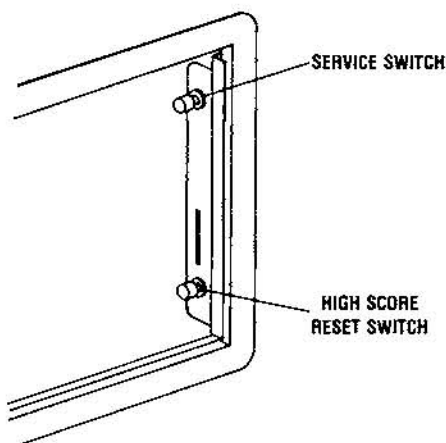

SERVICE SWITCH & HIGH SCORE RESET
FIGURE 5

COVER GLASS REMOVAL & DASH PANEL INSTALLATION

To remove the Cover Glass the following steps should be followed.

Cover Glass

- While holding the Cover Glass remove the three screws from the Cover Glass Bracket.
- Remove the bracket and lift the glass outward.

Dash Panel

To Install Dash Panel follow the steps listed below.

- Remove two bolts from Dash Panel.
- Disconnect Dash Panel Harness Connector.
- Release clamps and lift panel out.

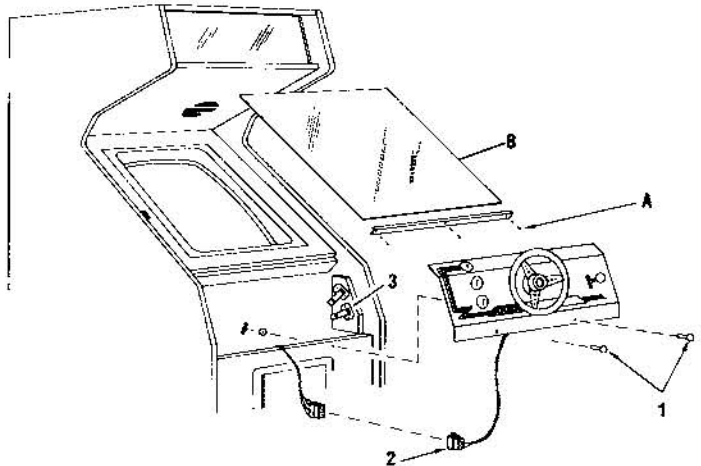

COVER GLASS REMOVAL & DASH PANEL
FIGURE 6

2. MAINTENANCE

All games require a certain amount of maintenance to keep them in good condition. A periodic check of mechanical controls would be beneficial to guarantee your game will be profitable.

A. CLEANING

The exterior of the game, all metal parts and all plastic parts can be cleaned with a non-abrasive cleanser. Caution should be used when cleaning the plastic, a dry cloth can cause scratches and result in a foggy appearance.

B. FUSE REPLACEMENT

This game uses 5 fuses, 4 are located on the Power Supply itself. See Figures 7 and 8 for fuse sizes and location.

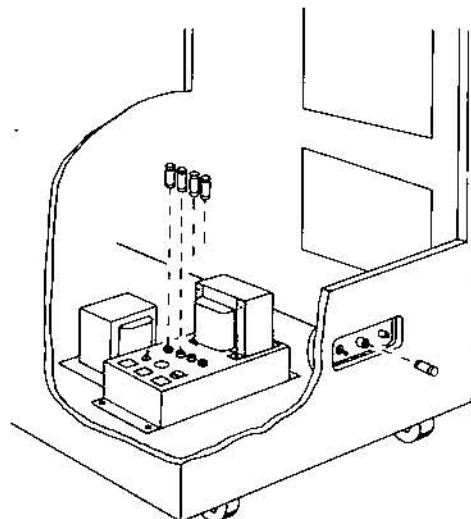

FUSE REPLACEMENT FIGURE 7

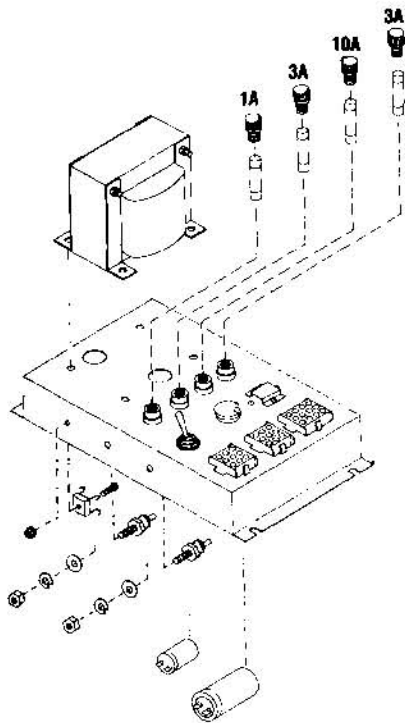

POWER SUPPLY FIGURE 8

C. VIDEO MONITOR REMOVAL

If you need to remove the Video Monitor, follow the instructions listed below:

CAUTION

It is recommended the game be left disconnected for at least one hour before removing the Video Monitor. This will probably discharge the Video Tube but **EXTREME CAUTION** is still necessary.

1. Disconnect power from the line voltage. (Not shown on Figure 9).
2. Disconnect the Monitor cable connector.
3. Remove the wire cable clamp. (Not shown on Figure 9).
4. Take out the two side bolts, one on each side of the cabinet.
5. Remove the (4) four mounting bolts and disconnect the green ground wire.
6. Slide the Monitor out by pulling the monitor toward you.

CAUTION

Use **EXTREME CAUTION** and do not touch electrical parts of the Monitor Yoke area with your hands or with any metal object in your hands! High voltages may exist in any Monitor, even with power disconnected.

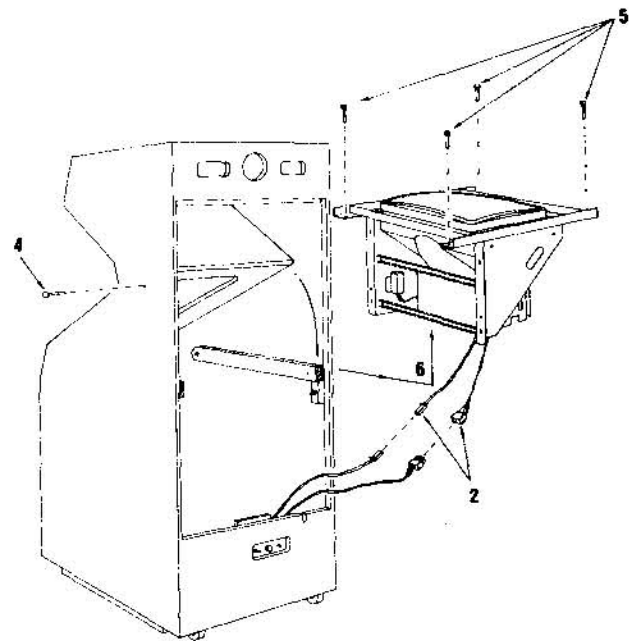

VIDEO MONITOR REMOVAL FIGURE 9

The Monitors purity is affected by the earth's magnetic field, causing a variation of color. By turning the game ON for 10 or 15 seconds and OFF for 20 to 30 minutes the automatic degaussing circuit applies as degaussing field around the edges of the monitor, doing this several times will correct the problem.

Another way to correct this problem is to purchase a bulk tape eraser at any Electronic Store, this will help to immediately demagnetize the Video Tube.

If you move the game to another location after degaussing the problem may reappear. Refer to Monitor Manual (72-00003-001) for further details.

D. VIDEO MONITOR ADJUSTMENTS

TAITO AMERICA CORPORATION presently uses either a Wells-Gardner Corporation or Electrohome 19" color Video Monitor in the "GRAND CHAMPION"™ upright game. Refer to the Monitor Manual (72-00003-001) for your specific Video Monitor. Be sure to heed all the **WARNINGS** and **CAUTION INSTRUCTIONS** provided before repairing or replacing your Video Monitor.

E. FLUORESCENT TUBE REPLACEMENT

CAUTION

If you drop a fluorescent tube and it breaks, it will **EXPLODE!** PLEASE USE CARE WHEN REPLACING.

- * Remove the three screws from the Marquee bracket, being sure to hold the glass while removing the screws.
- * Remove the Marquee Glass and the fluorescent bulb is accessible.
- * With both hands turn the bulb toward you, carefully pull the lamp out of the lamp socket.

F. PRINTED CIRCUIT BOARD REPLACEMENT

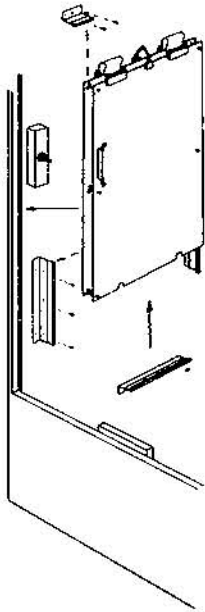

PRINTED CIRCUIT BOARD MOUNTING ASSEMBLY FIGURE 10

Remove side & top Mounting bracket. Remove boards by pushing back & up to slide the board set out.

WARNING

This equipment generates, uses, and can radiate radio frequency energy and if not installed and used in accordance with the Instruction Manual, may cause interference to radio communications. As temporarily permitted by Regulation it has not been tested for compliance pursuant to Subpart J of Part 15 of FCC Rules, which are designed to provide reasonable protection against such interference. Operation of this equipment in a residential area is likely to cause interference in which case the user at his own expense will be required to take whatever measures may be required to correct the interference.

CABINET ASSEMBLY (FRONT VIEW)**FIGURE 11**

ITEM	TAITO PART NO.	DESCRIPTION
1	47C00001-006	Marquee
2	63B00006-004	"U" Channel
3	61C00001-001	Marquee Retaining Bracket
4	47D00002-006	Cover Glass
5	61C00016-001	Glass Retaining Bracket
6	63-00003-001	Monitor Shroud
7	07-00086-001	Control Panel Assembly
8	07-00101-001	Coin Door Assembly
9	500060	Coin Funnel
10	500061	Coin Funnel Plate
11	500086	Mounting Bracket (Top)
12	115000	Counter, 6VDC
13	500091	Counter Bracket
14	400050	Cash Case
15	600006	Lock & Key (Cash Box)
16	500089	Cash Box Door
17	500087	Mounting Bracket (Bottom)
18	500088	Cash Box
19	63-00002-010	"T" Molding 84" Long
20	8862	Accelerator Pedal
21	61-00189-001	Foot Rest Bracket
22	63B00005-001	"L" Molding 33¼ " Long
23	44C00001-001	Wheel Assembly
24	42-00013-001	Cabinet
25	59-00008-001	Clamp
26	26B00009-001	Bayonet Base Socket
27	27-00002-001	Pilot, Lamp, 12V 150Ma
28	42-00125-001	Fluorescent Lamp Assembly
*29	09-00180-001	Main Harness
*30	79-50013-001	Instruction Card
*31	79-00036-001	Extra Label Set

*Item not shown on drawing

CABINET ASSEMBLY (FRONT VIEW)

FIGURE 11

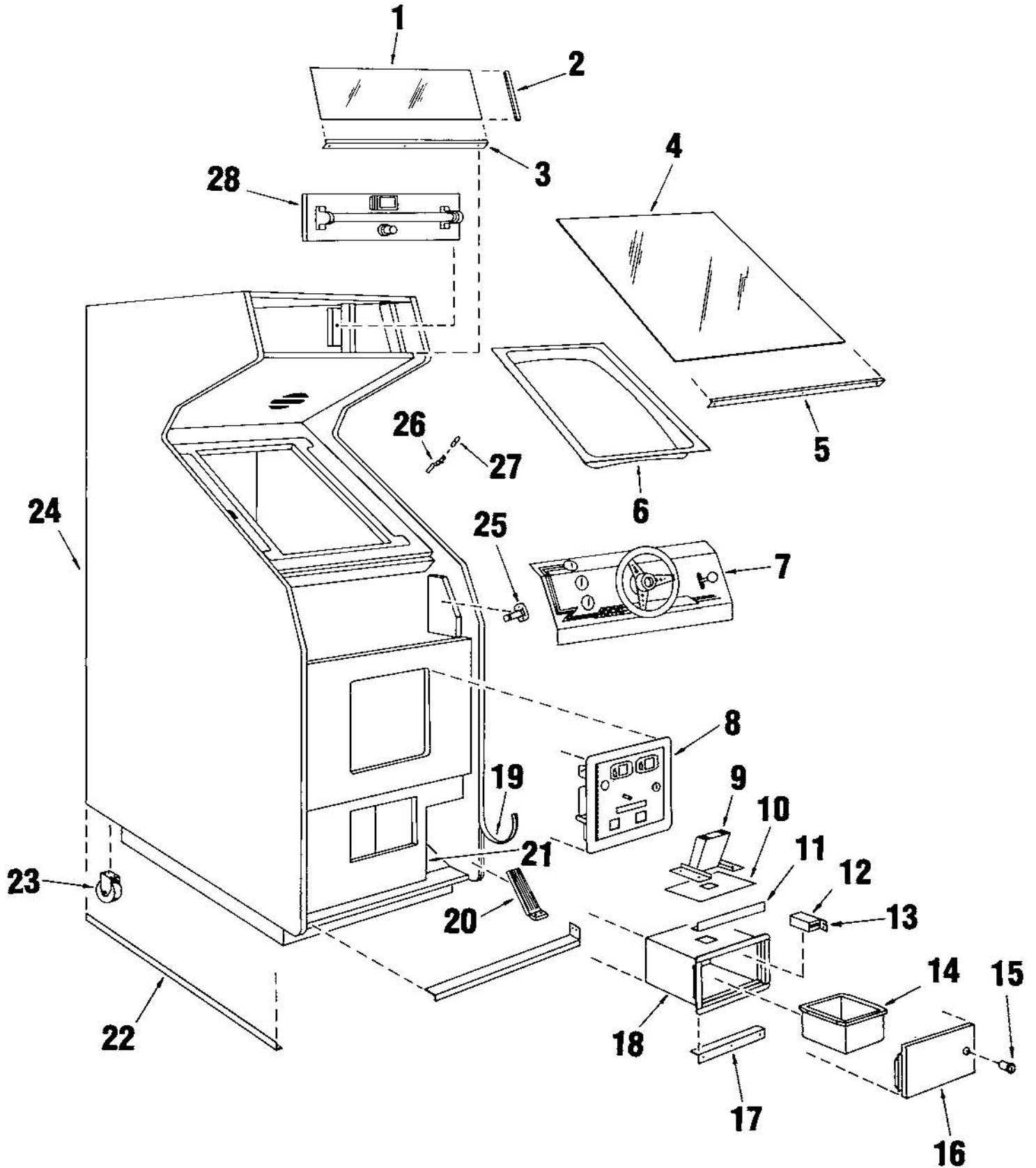

CABINET ASSEMBLY (REAR VIEW)**FIGURE 12**

ITEM	TAITO PART NO.	DESCRIPTION	REFERENCE
1	07-00084-001	Fan Assembly	
2	61-00165-001	Fan Screen	
3	04M00005-001	Speaker Assembly	
4	31-00009-001	19" Monitor	
	31-00010-001	19" Monitor	
5	45-00001-001	Lock & Key Assembly	
6	61C00086-001	Anchor Plate	
7	61C00080-001	Monitor Mounting Bracket	
8	42C00117-001	Monitor Cleat	
9	88110	Sound Board	
10	08-00023-001	Power Supply Board	
11	07-00092-001	Power Supply	
12	07-00003-001	Isolation Transformer	
13	61-00192-001	Isolation Transformer Plate	
14	63B00005-006	"L" Molding	
15	88100	CPU Board	
16	22B00001-001	Line Filter	
17	07-00094-001	Power ON/OFF Switch Assembly	
18		Switch Cover	AAO19542
19	61B00030-002	Switch Mounting Bracket	
20	29B00015-001	Interlock Switch	
21	07-00093-001	Accelerator Assembly	
22	42-00123-001	Rear Door	

CABINET ASSEMBLY (REAR VIEW)

FIGURE 12

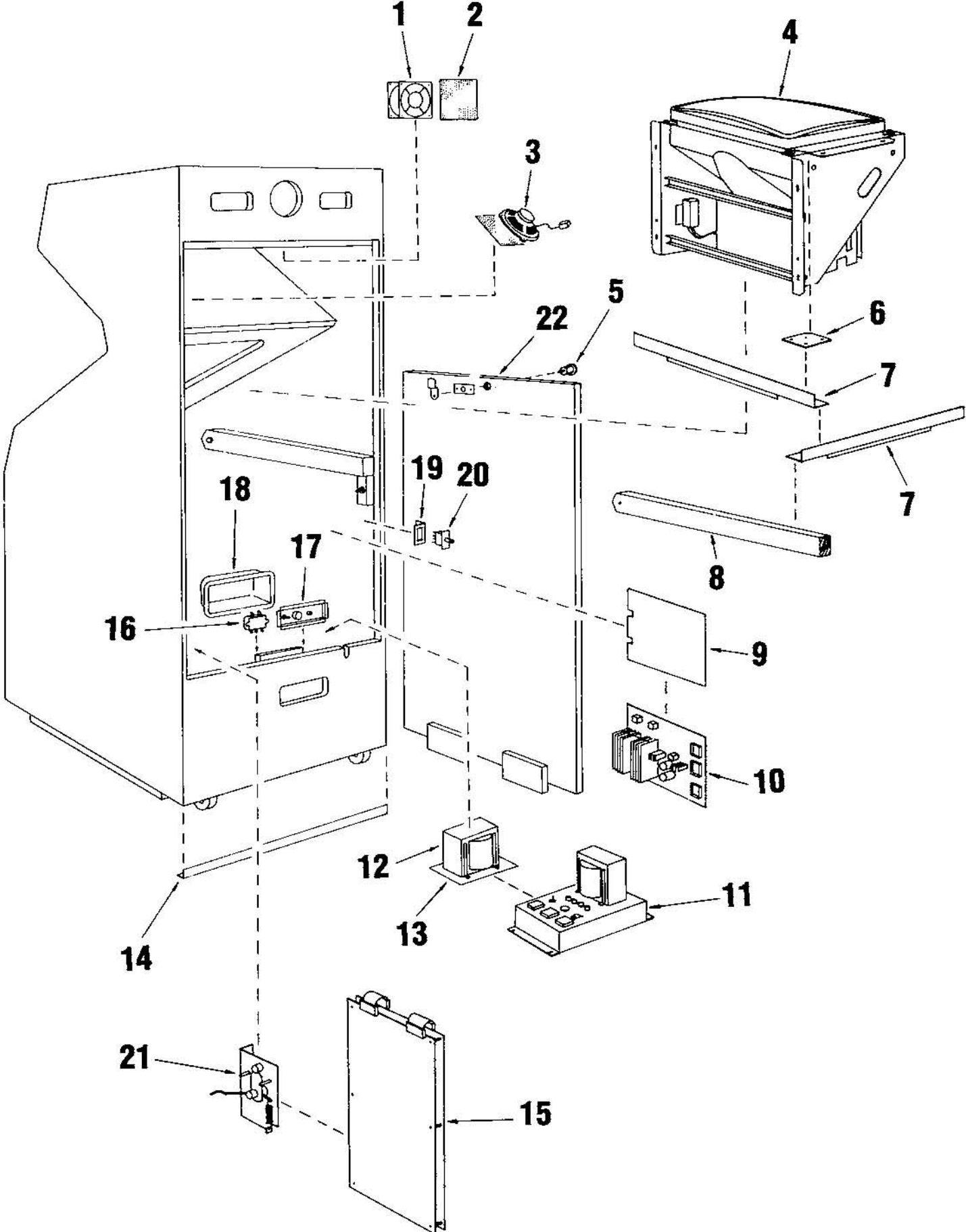

COIN DOOR & FRONT DOOR ASSEMBLY

FIGURE 13

ITEM	TAITO PART NO.	DESCRIPTION	REFERENCE
1	500010	Door Frame	AA026510
2	79-50005-001	Price U.S. 25¢	AA054704
3	27-00002-001	Pilot Lamp, 12V, 150Ma	AA055698
4	113001	Vinyl Socket	
5	61A00051-001	Coin Entry Plate for 25¢	AA016558
6	600006	Service Lock & Key No. 7900	AA016558
7	79A00016-001	Taito Name Tag	
8	500009	Coin Rejection Door	AA026511
9	500021-E	Cover Plate	AA019522
10	500021-I	Lock Plate	AA013578
11	500021-G	Coin Guide (B)	AA025508
12	500021-H	Coin Guide (A)	AA025507
13	500021-J	Tilt Switch	AA068717
14	61-00041-001	Lock Guard	AA013577
15	500021-K	Rejection Button	AA0027504
16	500021-L	Spring Cancel Holder	AA015504
17	024501	Service Switch	
18	500021-M	Cancel Lever	
19	500021-N	Rejector Bracket	AA013554
20	500021-P	Rejector Holder	AA023501
21	50054	Coin Guide	AA025503
22	199005	Insulator	AA019502
23	29-00007-001	Micro Switch	AA052512
24	370002	Actuator	AA053501
25	500021-H	Rejector Lever Connector	
26	59-00018-001	Coin Acceptor	
*27	09-00195-001	Coin Door Harness	

*Item not shown on drawing.

COIN DOOR & FRONT DOOR ASSEMBLY

FIGURE 13

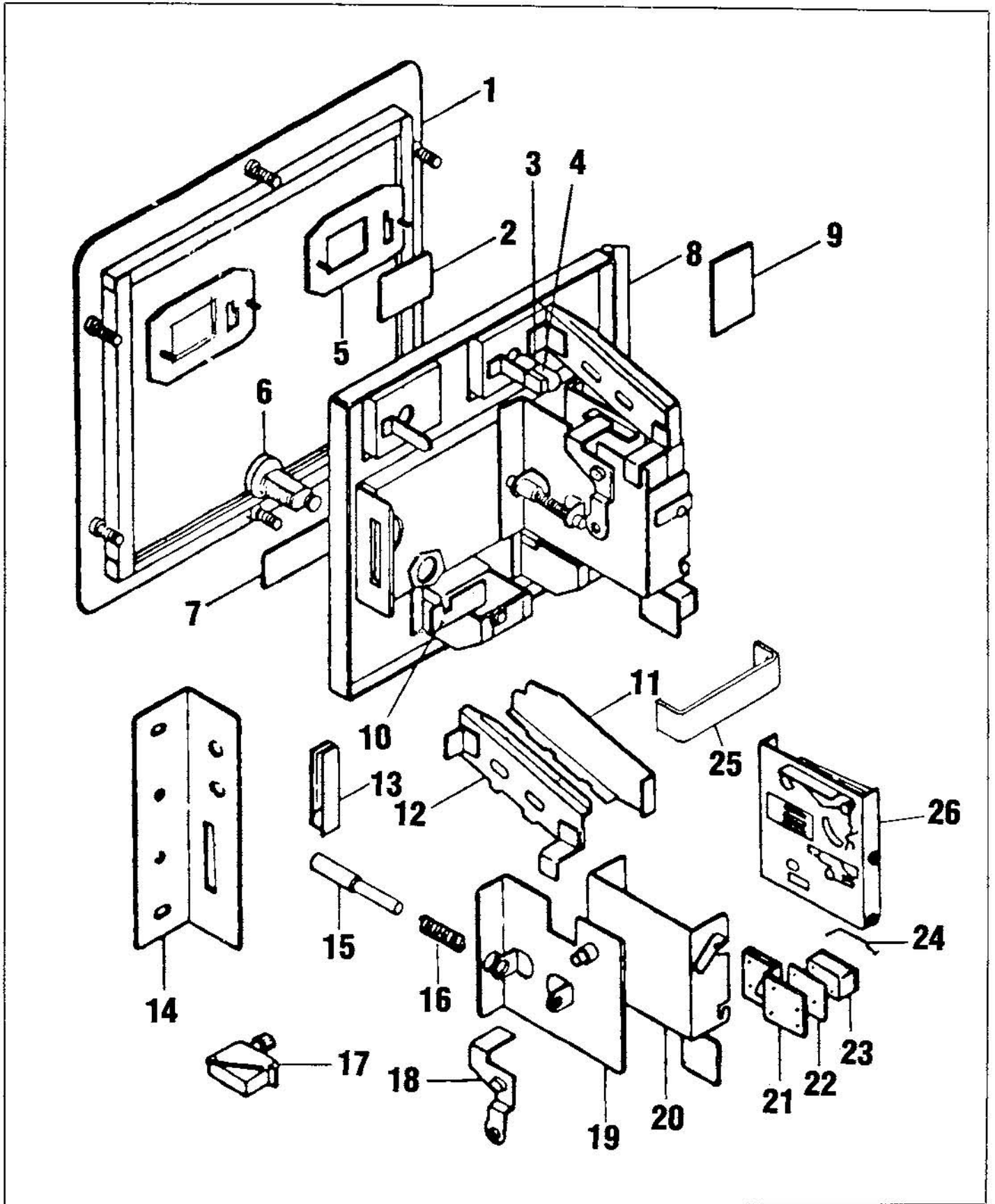

DASH PANEL

FIGURE 14

ITEM	TAITO PART NO.	DESCRIPTION
1	07-00090-001	Steering Wheel Assembly
2	07-00091-001	Shift Lever Assembly
3	63-00059-001	Lexan, Overlay
4	61-00196-001	Panel, Dash
5	61A00015-001	Strike Bracket
6	42-00122-001	Panel Support (Lower)
7	42-00121-001	Panel Support (Upper)
8	09-00181-001	Dash Panel Harness

DASH PANEL

FIGURE 14

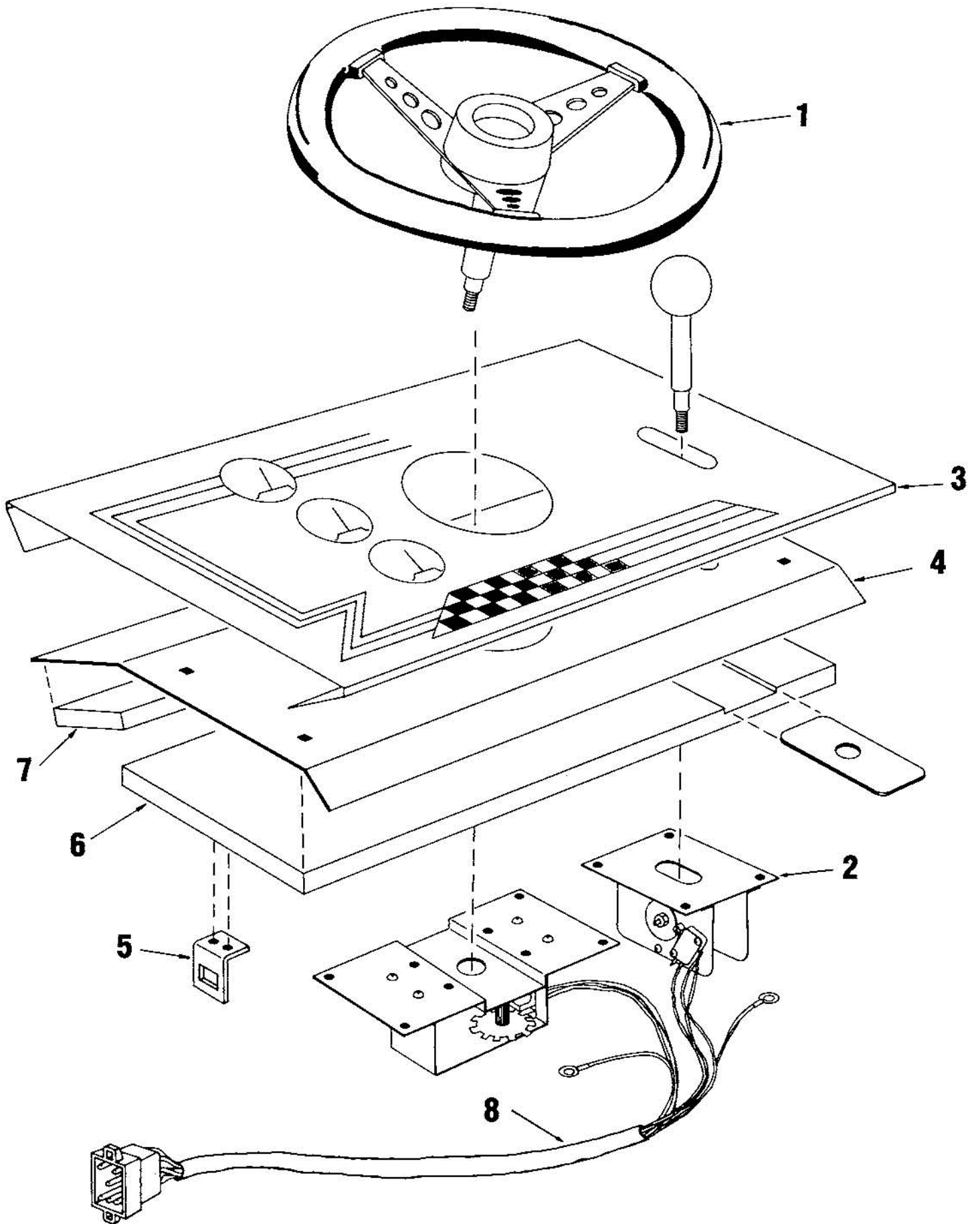

ACCELERATOR ASSEMBLY**FIGURE 15**

ITEM	TAITO PART NO.	DESCRIPTION	REFERENCE
1	09-00196-001	Accelerator Harness	
2	8861	Variable Resistor	AAT53024
3	8860	Volume Plate	SE030022
4	8882	C-Ring STW-12	
5	8859	Guide Shaft	SD020005
6	8849	Nut M6	
7	305016	Pan HD Screw M3X6	
8	8857	Stop Pin	SD020010
9	305025	Set Screw Socket M4X6	
10	8881	Gear	SD020003
11	8871	Accelerator Lever	EC020008
12	8877	Bushing	SE020006
13	390045	Plain Washer 6M	
14	390047	"E" Ring ETWJ-5	
15	8876	Felt Plug	SE090008
16	8875	Spring	SE050002
17	8880	"C" Ring STW-18	
18	8872	"C" Ring STW-10	
19	8878	Gear Segment	EC020007
20	8879	Spring	EC050001
21	8868	Pin	SD020004
22	8883	Rubber Stop	EC080001
23	8862	Accelerator Pedal	SD090006
24	8866	Accelerator Bracket	EC030020
25	8856	Pan HD Screw M5X20	
26	8869	Lock Washer 10M	
27	8870	Nut M10	
28	8863	Button Head Screw M5X 35	
29	8864	Plain Washer 5M	
30	352054	T-Nut M5	

ACCELERATOR ASSEMBLY

FIGURE 15

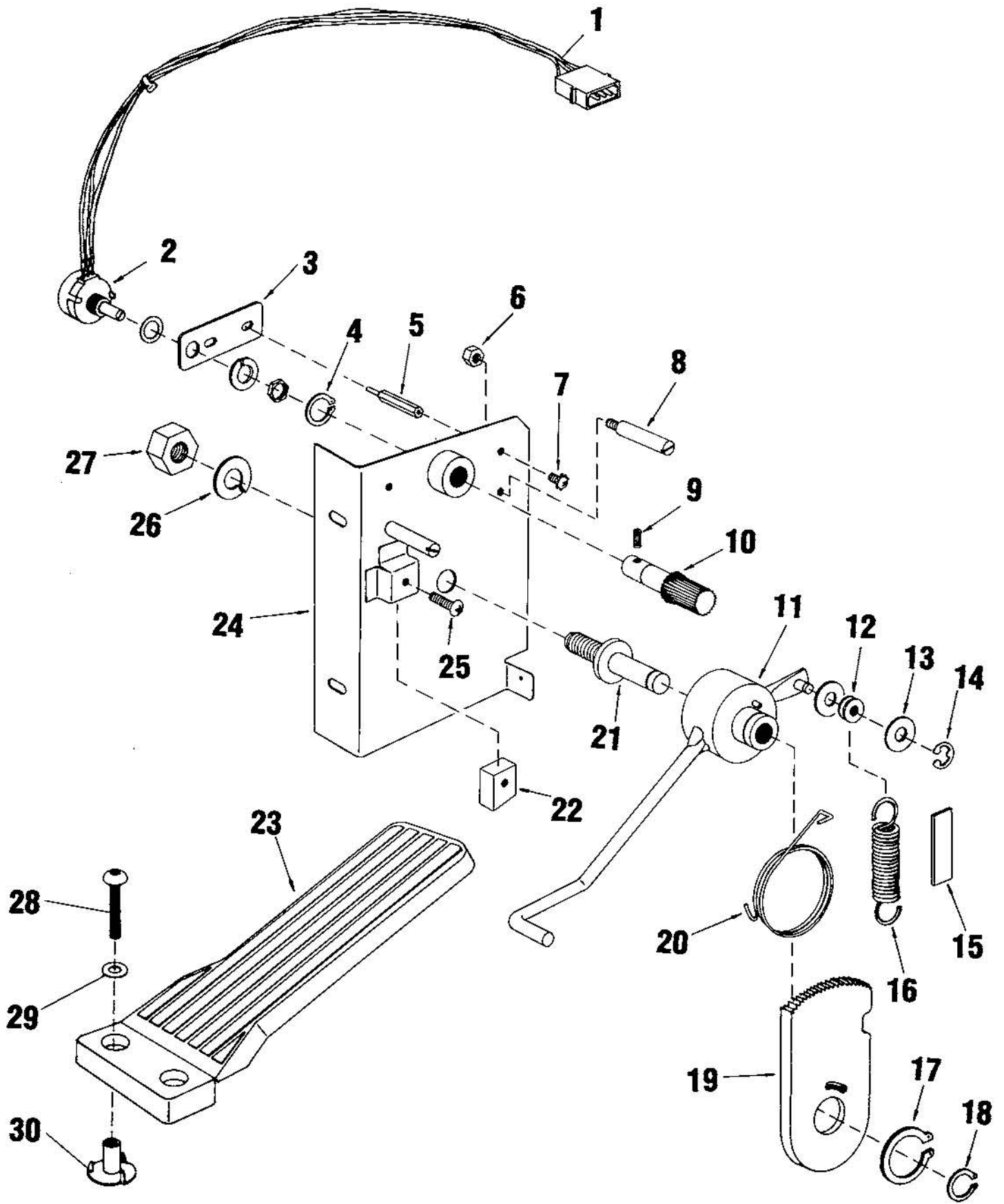

STEERING ASSEMBLY

FIGURE 16

ITEM	TAITO PART NO.	DESCRIPTION	REFERENCE
1	8814	Steering Cap	ECO90003
2	8818	Steering Wheel	SEO90004
3	8816	Retaining Plate Assembly	ECO30002
4	882	Pan HD Screw M6X25	
5	881	Hub Base (B)	GM0300020
6	390027	Star Washer	
7	885	Pan HD Screw M4X10	
8	305026	Pan HD Screw M4X8	
9	886	Hub Base (A)	GM030032
10	887	Flange Nut M6	
11	888	Hub (A)	GM020004
12	8810	Flange Bushing 80F-0406 (Oilless)	
13	8826	Gear	GM020003
14	8825	Pulse Cam	TE030009
15	8830	Photo Sensor PCB Assembly	TE000004
16	305026	Pan HD Screw M3X6	
17	8829	Sensor Board Bracket	GM030031
18	8828	Self Lock Nut M4	
19	8827	Spring Washer 4M	
20	352053	Flange Nut M4	
21	8824	Self Lock Nut M6	
22	8821	Spring Washer 6M	
23	8823	Gear	GM020002
24	8822	Spacer	JEO20005
25	883	Hub (B)	GM020005
26	8812	Steering Cover	SD090024
27	8813	C-Sink HD Screw 3.50X10	
28	8822	Spacer	JEO20005
29	8820	Cap Bolt M6X30	
30	8821	Spring Washer 6M	
31	8819	Steering Shaft	GM020008
32	8817	C-Sink HD Self Tap M4X10-2	
33	8815	Decoration Plate	ECO70008
34	884	Flange Bushing 80F-1512 (Oilless)	

STEERING ASSEMBLY

FIGURE 16

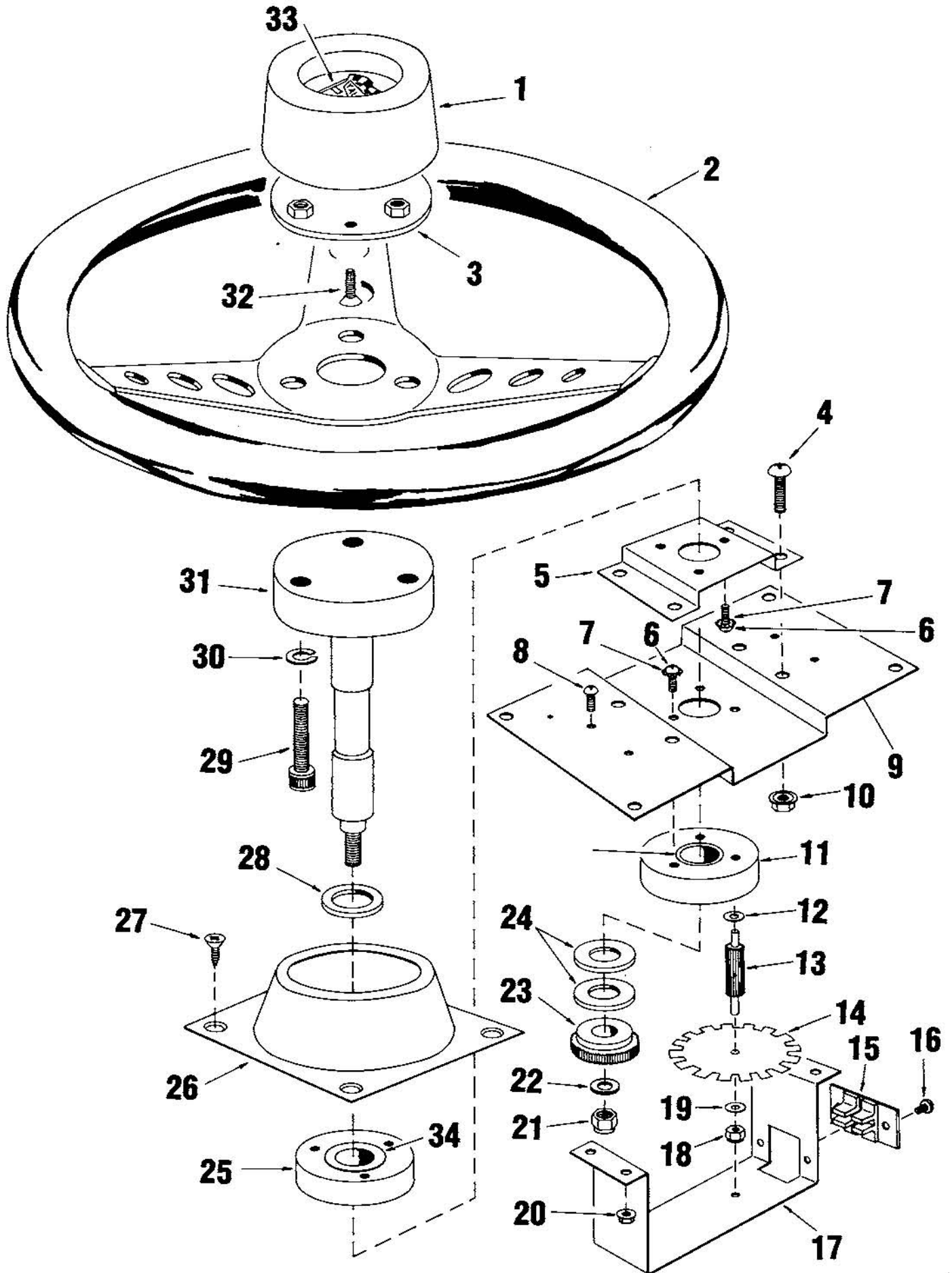

SHIFT LEVER ASSEMBLY**FIGURE 17**

ITEM	TAITO PART NO.	DESCRIPTION	REFERENCE
1	8852	Shift Knob	CH090002
2	8851	Mask	GM090003
3	8847	Lever	GM020006
4	305016	Pan HD Screw M3X6	
5	390028	Lock Washer 3M	
6	8848	Plain Washer 8M	
7	8840	Center Shaft	GM020007
8	390045	Plain Washer 6M	
9	8849	Nut M6	
10	8841	Shift Bracket	GM030022
11	8846	Spring	GM050001
12	390047	E-Ring ETWJ-4	
13	352054	Self Locking Nut M5	
14	8845	Spring Washer 5M	
15	8844	Guide Arm	GM030025
16	390028	Lock Washer	GM030021
17	305016	Pan HD Screw M3X6	
18	8850	Spacer	
19	8839	Tap Plate	AA013658
20	390028	Lock Washer 3M	
21	305018	Pan HD Screw M3X16	
22	199010	Insulation V-Type	AA019504
23	020503	Micro Switch	AA052532
24	8843	Spring Washer 5M	
25	8842	Cam	TE030010
26	8837	Rubber Bumper	GM080001
27	09-00181-001	Dash Panel Harness	

SHIFT LEVER ASSEMBLY

FIGURE 17

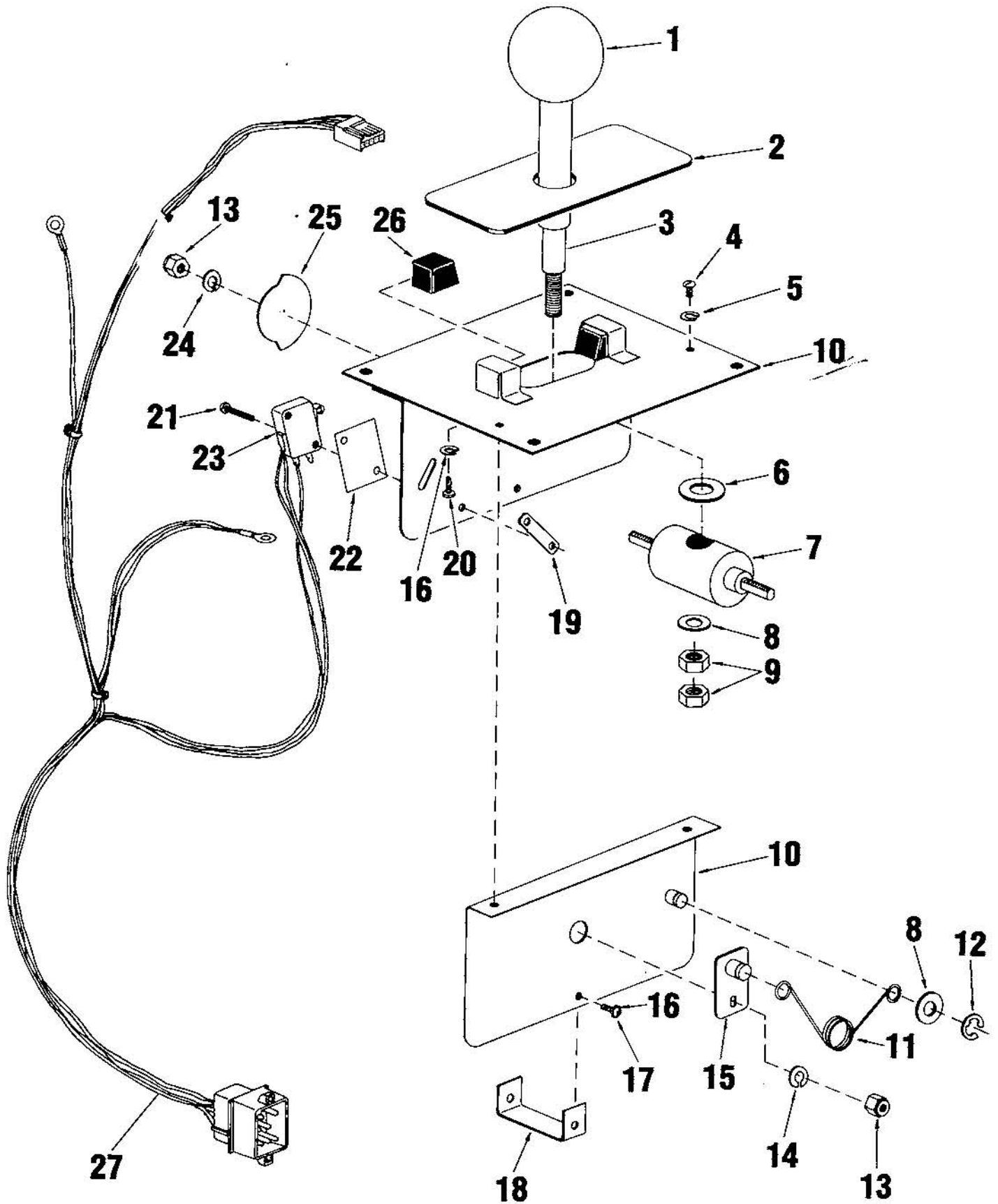

TIME & SCORE BOARD COMPONENT LAYOUT

FIGURE 18

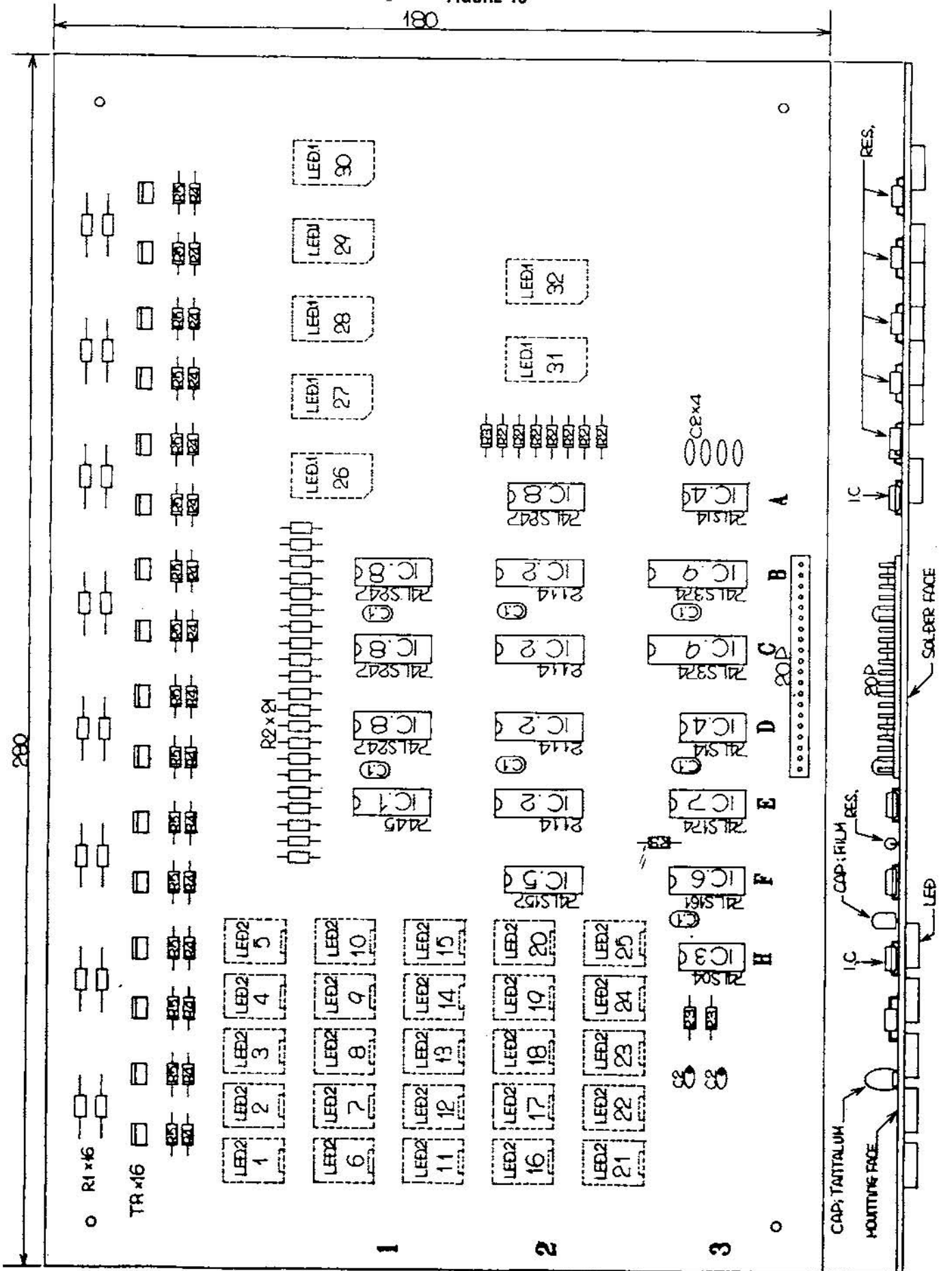

TIME & SCORE BOARD

FIGURE 18

ITEM	TAITO PART NO.	DESCRIPTION	REFERENCE
20P	8886	H-Connector Housing 20P	AA055220
LED 1	8887	LED TLR306	AA069514
TR	050012	Transistor 2SA509-0	AAT11032
LED 2	8888	LED TLR353	AAT12051
IC1	075032	TTL-IC 7445	AAT32132
IC2	078004	Static RAM 2114-4	AAT32156
IC3	076152	LS-IC 74LS04	AAT33005
IC4	076010	LS-IC 74LS14	AAT33015
IC5	076060	LS-IC 74LS157	AAT33112
IC6	076063	LS-IC 74LS161	AAT33116
IC7	076151	LS-IC 74LS174	AAT33127
IC8	076090	LS-IC 74LS247	AAT33159
IC9	076122	LS-IC 74LS374	AAT33209
C1	8889	Capacitor, Film TDY-1H-104	AAT41244
C2	025024	Capacitor, Ceramic 470pf,50V	AAT41334
C3	8896	Capacitor, Tantalum SSG-OR68F	AAT41435
R1	001039	Resistor, Carbon 390 ohm	AAT51053
R2	001059	Resistor, Carbon 2K ohm, $\frac{1}{2}W \pm 5\%$	AAT51072
R3	000067	Resistor, Carbon 1K ohm, $\frac{1}{4}W \pm 5\%$	AAT51765
R4	000093	Resistor, Carbon 12K ohm, $\frac{1}{4}W \pm 5\%$	AAT51767
R5	000081	Resistor, Carbon 3.9K ohm, $\frac{1}{4}W \pm 5\%$	AAT51779

CPU PC BOARD COMPONENT LAYOUT

FIGURE 19

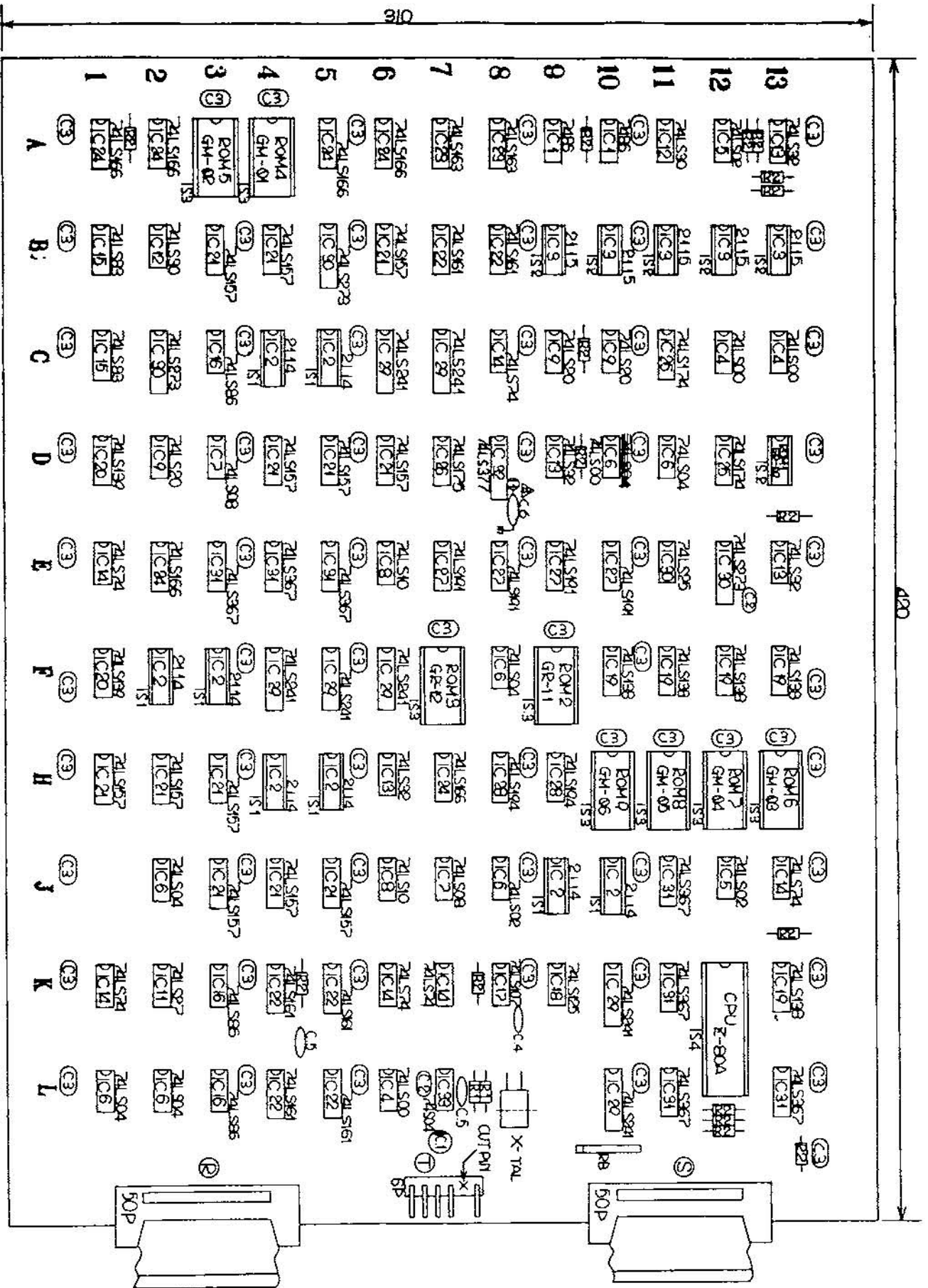

CPU PC BOARD

FIGURE 19

ITEM	TAITO PART NO.	DESCRIPTION	REFERENCE
50P	998501	F.R.C. Harness Assembly	AAS00262
IS1	88101	IC Socket 18P	AA055103
6P	88102	SL156 Post Header (Side) 6P	AA055326
IS2	88103	IC Socket 16P	AA055786
IS3	88104	IC Socket 24P	AA055787
IS4	88105	IC Socket 40P	AA055812
X-TAL	998306	X-TAL 18.432	AA069590
IC1	075055	TTL-IC 7486	AAT32013
IC2	078004	Static RAM 2114	AAT32156
IC3	15-10009-001	S-RAM	AAT32169
IC4	076000	LS-IC 74LS00	AAT33001
IC5	076001	LS-IC 74LS02	AAT33003
IC6	076003	LS-IC 74LS04	AAT33005
IC7	076005	LS-IC 74LS08	AAT33009
IC8	076007	LS-IC 74LS10	AAT33011
IC9	076012	LS-IC 74LS20	AAT33019
IC10	076153	LS-IC 74LS25	AAT33022
IC11	176016	LS-IC 74LS27	AAT33024
IC12	076018	LS-IC 74LS30	AAT33026
IC13	076019	LS-IC 74LS32	AAT33027
IC14	076032	LS-IC 74LS74	AAT33051
IC15	076035	LS-IC 74LS88	AAT33059
IC16	076037	LS-IC 74LS86	AAT33062
IC17	076043	LS-IC 74LS107	AAT33076
IC18	076048	LS-IC 74LS125	AAT33089
IC19	076053	LS-IC 74LS138	AAT33096
IC20	076054	LS-IC 74LS139	AAT33092
IC21	076060	LS-IC 74LS157	AAT33112
IC22	076063	LS-IC 74LS161	AAT33116
IC23	076065	LS-IC 74LS163	AAT33118
IC24	076146	LS-IC 74LS166	AAT33121
IC25	076072	LS-IC 74LS174	AAT33127

ITEM	TAITO PART NO.	DESCRIPTION	REFERENCE
IC26	076073	LS-IC 74LS175	AAT33128
IC27	076077	LS-IC 74LS191	AAT33141
IC28	076080	LS-IC 74LS194	AAT33144
IC29	076085	LS-IC 74LS241	AAT33153
IC30	076103	LS-IC 74LS273	AAT33170
IC31	076119	LS-IC 74LS367	AAT33203
IC32	076124	LS-IC 74LS377	AAT33221
CPU	077002	CPU 2-80A	AAT34008
IC33	075703	S-IC 74LS04	AAT38003
ROM1	88GR00	P-ROM (24S288)	GRO90019
ROM2	88GR11	P-ROM (2532) GR-11	GRO90021
ROM3	88GR12	P-ROM (2532) GR-12	GRO90022
ROM4	88GR01	P-ROM (2532) GM-01	GRO00005
ROM5	88GR02	P-ROM (2532) GM-02	GMO00006
ROM6	88GR08	P-ROM (2532) GM-08	GMO90007
ROM7	88GR04	P-ROM (2532) GM-04	GMO90008
ROM8	88GR05	P-ROM (2532) GM-05	GMO90009
ROM9	88GR06	P-ROM (2532) GM-06	GMO90010
C1	88106	Capacitor, Electrolytic 25VB100	AAT41036
C2	88107	Capacitor, Film TDY-1H-102	AAT41232
C3	8889	Capacitor, Film TDY-1H-104	AAT41244
C4	025020	Capacitor, Ceramic 100pf, 50V	AAT41318
C5	025027	Capacitor, Ceramic 180pf, 50V	AAT41324
R1	88108	Resistor, Carbon 330 ohm, 1/4W ± 5%	ATT51753
R2	000067	Resistor, 1K ohm, 1/4W ± 5%	AAT51765
RB	997631	Resistor, Block 1K ohm, 8 elements	AAT55036
C6	025028	Capacitor, Ceramic 68pf, 50V	AAT41314

GAME PC BOARD COMPONENT LAYOUT

FIGURE 20

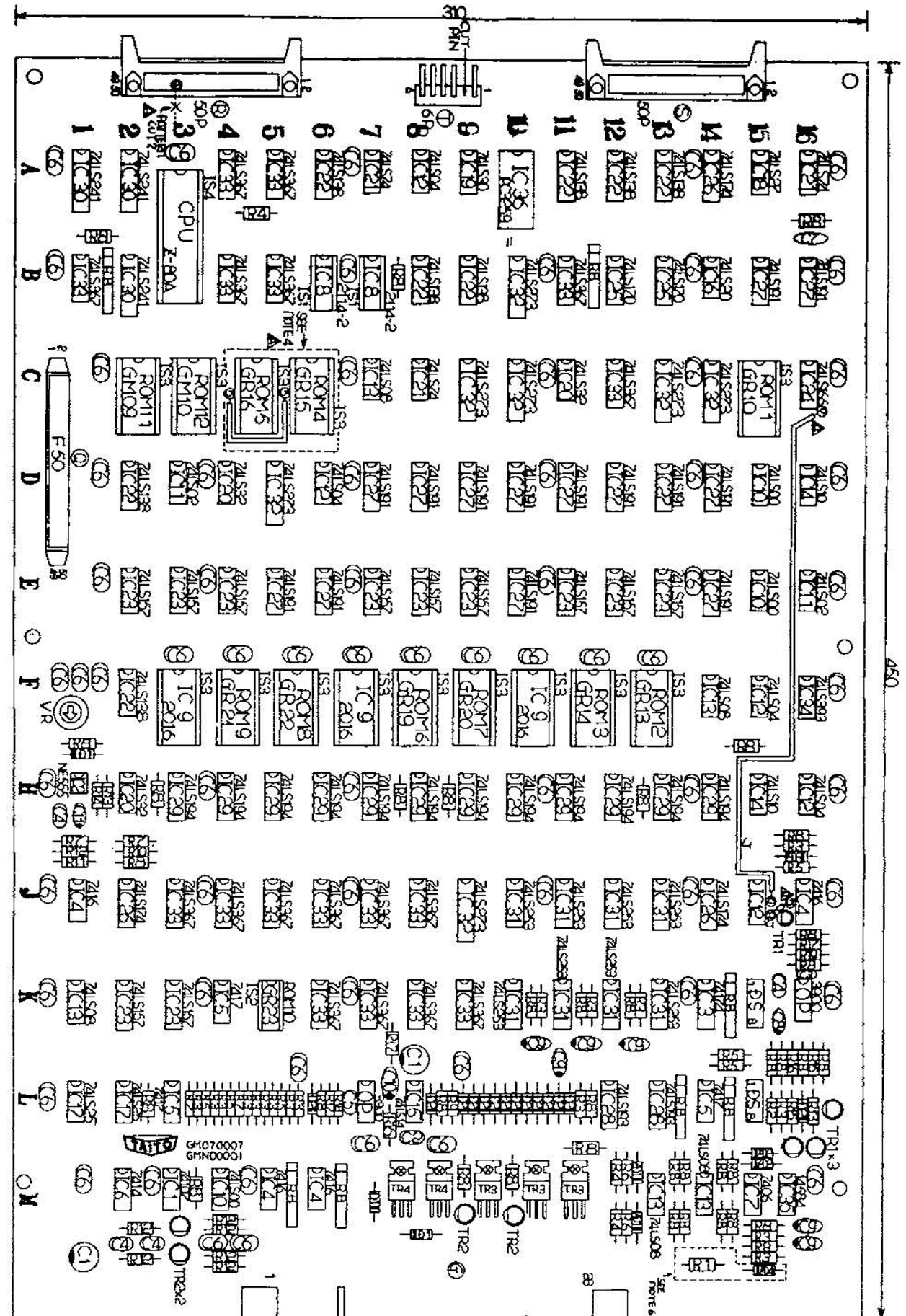

GAME PC BOARD

FIGURE 20

ITEM	TAITO PART NO.	DESCRIPTION	REFERENCE	ITEM	TAITO PART NO.	DESCRIPTION	REFERENCE
DS	88116	Dip Switch DSS-8	AAO 52566	IC28	076079	LS - IC 74LS193	AAT 33143
IS1	88101	IC Socket 18P	AAT 55103	IC29	076080	LS - IC 74LS194	AAT 33144
50P	88117	Angle Pin Header 50P	AAT 55310	IC30	076085	LS - IC 74LS241	AAT 33153
F50	88118	Flat Pin Header 50P	AAT 55315	IC31	076094	LS - IC 74LS253	AAT 33163
6P	88119	S1156 Post Header 6P	AAT 55326	IC32	076070	LS - IC 74LS273	AAT 33170
IS2	88103	IC Socket 16P	AAT 55786	IC33	076119	LS - IC 74LS367	AAT 33203
IS3	88120	IC Socket 24P	AAT 55787	IC34	076129	LS - IC 74LS393	AAT 33220
IS4	88105	IC Socket 40P	AAT 55812	CPU	077002	CPU 2-80A	AAT 34008
TR1	997967	Transistor 2SC458-C	AAT 11005	IC35	88123	C-MOS MC14584	AAT 36105
TR2	050001	Transistor 2SC372-0	AAT 11020	IC36	88124	Custom IC PC3259	AAT 37003
TR3	050002	Transistor 2SC1060-B	AAT 11030	ROM 1	88GR10	P-ROM (2716) GR10	GRO 90020
TR4	050004	Transistor 2SA473-D	AAT 11040	ROM 2	88GR13	P-ROM (2532) GR13	GRO 90023
D1	998019	Diode V03V	AAT 12002	ROM 3	88GR14	P-ROM (2532) GR14	GRO 90024
D2	998020	Diode 1S188	AAT 12025	ROM 4	88GR15	P-ROM (2532) GR15	GRO 90025
ZD1	88120	Zener Diode RD4.7EC	AAT 13025	ROM 5	88GR16	P-ROM (2532) GR16	GRO 90026
ZD2	88121	Zener Diode RD5.6EB	AAT 13026	ROM 6	88GR19	P-ROM (2532) GR19	GRO 90029
ZD3	998014	Zener Diode RD9A-M	AAT 13028	ROM 7	88GR20	P-ROM (2532) GR20	GRO 90030
ZD4	88122	Zener Diode RD12EB	AAT 13035	ROM 8	88GR21	P-ROM (2532) GR21	GRO 90031
OP	179000	OP Amplifier TM3900	AAT 31011	ROM 9	88GR22	P-ROM (2532) GR22	GRO 90032
TC1	075069	TTL - IC 74107	AAT 32016	ROM 10	88GR23	P-ROM (74S288) GR23	GRO 90033
IC2	080014	TTL - IC NE555V	AAT 32019	ROM 11	88GM09	P-ROM (2532) 6M09	GMO 90013
IC3	075110	TTL - IC 74174	AAT 32029	ROM 12	88GM10	P-ROM (2532) 6M10	GMO 90014
IC4	075014	TTL - IC 7416	AAT 32033	C1	88106	Capacitor, Electrolytic 25VP100	AAT 41036
IC5	075015	TTL - IC 7417	AAT 32049	C2	88107	Capacitor, Film TDY-1H-102	AAT 41232
IC6	075013	TTL - IC 7414	AAT 32054	C3	88151	Capacitor, Film TDY-1H-332	AAT 41235
IC7	075006	TTL - IC 7406	AAT 32112	C4	88134	Capacitor, Film TDY-1H-103	AAT 41238
IC8	078055	Static RAM	AAT 32163	C5	88152	Capacitor, Film TDY-1H-333	AAT 41241
IC9	078006	Static RAM TMM2016P	AAT 32178	C6	8889	Capacitor, Film TDY-1H-104	AAT 41244
IC10	076000	LS - IC 74LS00	AAT 33001	C7	025027	Capacitor, Ceramic DT-203 180P	AAT 41324
IC11	076001	LS - IC 74LS02	AAT 33003	C8	88153	Capacitor, Tantalum SSG25-1F	AAT 41425
IC12	076003	LS - IC 74LS04	AAT 33005	C9	88154	Capacitor, Tantalum SSG25-4R7F	AAT 41428
IC13	076005	LS - IC 74LS08	AAT 33009	C10	88155	Capacitor, Tantalum SSG25-10F	AAT 41430
IC14	076007	LS - IC 74LS10	AAT 33011	C11	88156	Capacitor, Tantalum SSG35-OR1F	AAT 41431
IC15	076010	LS - IC 74LS14	AAT 33015	R1	001090	Resistor, Carbon 100K ohm 1/2W ± 5%	AAT 51455
IC16	076012	LS - IC 74LS20	AAT 33019	R2	000091	Resistor, Carbon 10K ohm 1/4W ± 5%	AAT 51717
IC17	076014	LS - IC 74LS25	AAT 33022	R3	000043	Resistor, Carbon 100K ohm 1/4W ± 5%	AAT 51741
IC18	076016	LS - IC 74LS27	AAT 33024	R4	000051	Resistor, 220K ohm 1/4W ± 5%	AAT 51749
IC19	076018	LS - IC 74LS30	AAT 33026	R5	000053	Resistor, 270K ohm 1/4W ± 5%	AAT 51751
IC20	076019	LS - IC 74LS32	AAT 33027				
IC21	076032	LS - IC 74LS74	AAT 33051				
IC22	076053	LS - IC 74LS138	AAT 33096				
IC23	076060	LS - IC 74LS157	AAT 33112				
IC24	076146	LS - IC 74LS166	AAT 33121				
IC25	076070	LS - IC 74LS170	AAT 33124				
IC26	076151	LS - IC 74LS174	AAT 33127				
IC27	076054	LS - IC 74LS191	AAT 33141				

GAME PC BOARD

FIGURE 20

ITEM	TAITO PART NO.	DESCRIPTION	REFERENCE
R6	000129	Resistor, 390K ohm 1/4W ± 5%	AAT 51755
R7	000059	Resistor, 470K ohm 1/4W ± 5%	AAT 51757
R8	000067	Resistor, 1K ohm 1/4W ± 5%	AAT 51765
R9	000074	Resistor, 2K ohm 1/4W ± 5%	AAT 51772
R10	000099	Resistor, 22K ohm 1/4W ± 5%	AAT 51773
R11	000103	Resistor, 3.3K ohm 1/4W ± 5%	AAT 51777
R12	000083	Resistor, Carbon 4.7K ohm 1/4W ± 5%	AAT 51781
R13	000091	Resistor, Carbon 10K ohm 1/4W ± 5%	AAT 51789
R14	000099	Resistor, Carbon 22K ohm 1/4W ± 5%	AAT 51797
R15	000101	Resistor, Carbon 27K ohm 1/4W ± 5%	AAT 51799
R16	000035	Resistor, Carbon 47K ohm 1/4W ± 5%	AAT 51805
R17	000129	Resistor, Carbon 390K ohm 1/4W ± 5%	AAT 51827
R18	000061	Resistor, Carbon 560K ohm 1/4W ± 5%	AAT 51831
R19	000067	Resistor, Carbon 1M ohm 1/4W ± 5%	AAT 51837
VR	88157	Variable Resistor, B-2K	AAT 53030
RB	997631	Resistor Block, 1 ohm 8 elements	AAT 55036

SOUND PC BOARD COMPONENT LAYOUT

FIGURE 21

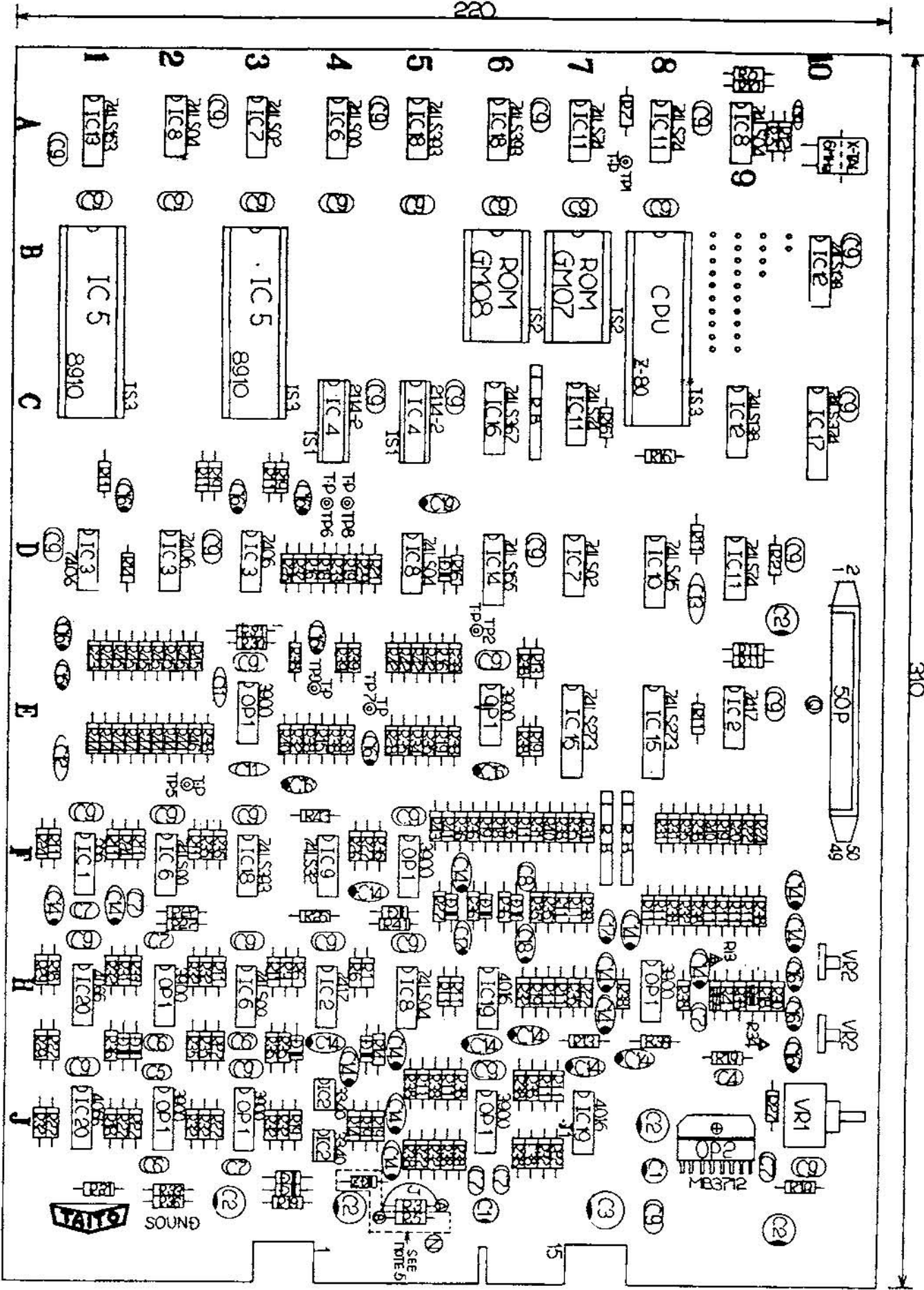

SOUND PC BOARD

FIGURE 21

ITEM	TAITO PART NO.	DESCRIPTION	REFERENCE
IS1	998501	IC Socket 18P	AAO 55103
50P	88118	Flat Pin Header 50P	AAO 55315
IS2	88104	IC Socket 24P	AAO 55787
IS3	88105	IC Socket 40P	AAO 55812
TP	88143	Test Point Chip	AAO 56548
X-TAL	88144	X-Tal 6MHZ	AAO 69593
D	998020	Diode 1S1588	AAT 12025
ZD	88122	Zener Diode RD12FB	AAT 13035
OP1	079000	OP Amplifier LM3990	AAT 31011
IC1	88145	Timer IC	AAT 31028
IC2	88146	Attenuator MC3340	AAT 31031
OP2	079002	OP Amplifier MB3712	AAT 31042
	305016	Pan Head Screw M3X6	
	88124	Nut M3	
IC2	075015	TTL-IC 7417	AAT 32049
IC3	075006	TTL-IC 7406	AAT 32112
IC4	078005	Static RAM 2114-2	AAT 32163
IC5	083001	Sound IC AY-38910	AAT 32165
IC6	076000	IC - 74LS00	AAT 33001
IC7	076001	IC - 74LS02	AAT 33003
IC8	078003	IC - 74LS04	AAT 33005
IC9	076019	IC - 74LS32	AAT 33027
IC10	076156	IC - 74LS45	AAT 33034
IC11	078032	IC - 74LS74	AAT 33051
IC12	076053	IC - 74LS138	AAT 33096
IC13	076057	IC - 74LS153	AAT 33108
C18	88147	Cap, Tantalum SS635-3R3F	AAT 41438
C19	88148	Cap, Tantalum SSG35-4R7F	AAT 41439
R1	000035	Resistor, Carbon 47 ohm 1/4W ± 5%	AAT 51733
R2	000039	Resistor, Carbon 68 ohm 1/4W ± 5%	AAT 51737
R3	000043	Resistor, Carbon 100 ohm 1/4W ± 5%	AAT 51741
R4	000047	Resistor, Carbon 150 ohm 1/4W ± 5%	AAT 51745
R5	000051	Resistor, Carbon 220 ohm 1/4W ± 5%	AAT 51749
R6	000053	Resistor, Carbon 270 ohm 1/4W ± 5%	AAT 51751
R7	000055	Resistor, Carbon 330 ohm 1/4W ± 5%	AAT 51753
R9	000059	Resistor, Carbon 470 ohm 1/4W ± 5%	AAT 51757
R10	000061	Resistor, Carbon 560 ohm 1/4W ± 5%	AAT 51759
R11	000067	Resistor, Carbon 1K ohm 1/4W ± 5%	AAT 51765
R12	000097	Resistor, Carbon 18K ohm 1/4W ± 5%	AAT 51771

ITEM	TAITO PART NO.	DESCRIPTION	REFERENCE
R13	000101	Resistor, Carbon 27K ohm 1/4W ± 5%	AAT 51775
R14	000103	Resistor, Carbon 33K ohm 1/4W ± 5%	AAT 51801
R15	000105	Resistor, Carbon 39K ohm 1/4W ± 5%	AAT 51803
R16	000107	Resistor, Carbon 47K ohm 1/4W ± 5%	AAT 51781
R18	000113	Resistor, Carbon 82K ohm 1/4W ± 5%	AAT 51787
R19	000091	Resistor, Carbon 10K ohm 1/4W ± 5%	AAT 51789
R20	000095	Resistor, Carbon 15K ohm 1/4W ± 5%	AAT 51793
R21	000098	Resistor, Carbon 20K ohm 1/4W ± 5%	AAT 51796
R22	000099	Resistor, Carbon 22K ohm 1/4W ± 5%	AAT 51797
R23	000102	Resistor, Carbon 30K ohm 1/4W ± 5%	AAT 51800
R24	000103	Resistor, Carbon 33K ohm 1/4W ± 5%	AAT 51724
R25	000105	Resistor, Carbon 39K ohm 1/4W ± 5%	AAT 51725
R26	000107	Resistor, Carbon 47K ohm 1/4W ± 5%	AAT 51805
R27	000115	Resistor, Carbon 100K ohm 1/4W ± 5%	AAT 51813
R28	000117	Resistor, Carbon 120K ohm 1/4W ± 5%	AAT 51815
IC14	076058	IC 74LS155	AAT 33110
IC15	076103	IC 74LS273	AAT 33170
IC16	076119	IC 74LS367	AAT 33203
IC17	076122	IC 74LS374	AAT 33209
IC18	076155	IC 74LS220	AAT 33220
CPU	076506	CPU	AAT 34021
IC19	076501	C-MOS CD4016A	AAT 36017
IC20	15-44066001	C-MOS CD4066B	AAT 36067
ROM 1	886M07	P-ROM (2532) 6M07	6M0 90011
ROM 2	896M08	P-ROM (2532) 6M08	6M0 90012
C1	88130	Cap, Electrolytic 25VB-47	AAT 41035
C2	88106	Cap, Electrolytic 25VB-100	AAT 41036
C3	88131	Cap, Electrolytic 25VB-220	AAT 41037
C4	88107	Cap, Film TDY-1H-102	AAT 41232
C5	88132	Cap, Film TDY-1H-222	AAT 41234
C6	88133	Cap, Film TDY-1H-472	AAT 41236
C7	88134	Cap, Film TDY-1H-103	AAT 41238
C8	88135	Cap, Film TDY-1H-223	AAT 41240
C9	8889	Cap, Film TDY-1H-104	AAT 41244
C10	88136	Cap, Cermic DT-200 22P	AAT 41302
C11	88137	Cap, Cermic DT-200 42P	AAT 41310

SOUND PC BOARD

FIGURE 21

ITEM	TAITO PART NO.	DESCRIPTION	REFERENCE	ITEM	TAITO PART NO.	DESCRIPTION	REFERENCE
C12	025027	Cap, Cermic DT-203 180P	AAT 41324	ROM 1	88GR10	P-ROM (2716) GR10	GRO 90020
C13	025024	Cap, Cermic DT-205 470P	AAT 41334	ROM 2	88GR13	P-ROM (2532) GR13	GRO 90023
C14	88138	Cap, Tantalum SSG25-10F	AAT 41430	ROM 3	88GR14	P-ROM (2532) GR14	GRO 90024
C15	88139	Cap, Tantalum SSG35-0R1F	AAT 41431	ROM 4	88GR15	P-ROM (2532) GR15	GRO 90025
C16	88140	Cap, Tantalum SSG35-1F	AAT 41436	ROM 5	88GR16	P-ROM (2532) GR16	GRO 90026
C17	88141	Cap, Tantalum SSG35-2R2F	AAT 41437	ROM 6	88GR19	P-ROM (2532) GR19	GRO 90029
R29	000119	Resistor, Carbon 150K ohm 1/4W ± 5%	AAT 51817	ROM 7	88GR20	P-ROM (2532) GR20	GRO 90030
R30	000121	Resistor, Carbon 180K ohm 1/4W ± 5%	AAT 51819	ROM 8	88GR21	P-ROM (2532) GR21	GRO 90031
R31	000123	Resistor, Carbon 220K ohm 1/4W ± 5%	AAT 51821	ROM 9	88GR22	P-ROM (2532) GR22	GRO 90032
R32	000123	Resistor, Carbon 220K ohm 1/4W ± 5%	AAT 51823	ROM 10	88GR23	P-ROM (74LS288) GR23	GRO 90033
R33	000127	Resistor, Carbon 330K ohm 1/4W ± 5%	AAT 51825	ROM 11	88GM09	P-ROM (2532) 6M09	GMO 90013
R34	000129	Resistor, Carbon 390K ohm 1/4W ± 5%	AAT 51827	ROM 12	88GM10	P-ROM (2532) 6M10	GMO 90014
R35	000131	Resistor, Carbon 470K ohm 1/4W ± 5%	AAT 51829	C1	88106	Capacitor, Electrolytic 25VP100	AAT 41036
R36	000133	Resistor, Carbon 560K ohm 1/4W ± 5%	AAT 51831	C2	88107	Capacitor, Film TDY-1H-102	AAT 41232
R37	000135	Resistor, Carbon 680K ohm 1/4W ± 5%	AAT 57833	C3	88150	Capacitor, Film TDY-1H-332	AAT 41235
R38	000139	Resistor, Carbon 1M ohm 1/4W ± 5%	AAT 51837	C4	88151	Capacitor, Film TDY-1H-103	AAT 41238
R39	000145	Resistor, Carbon 1.8M ohm 1/4W ± 5%	AAT 51843	C5	88152	Capacitor, Film TDY-1H-333	AAT 41241
R40	000147	Resistor, Carbon 2.2M ohm 1/4W ± 5%	AAT 51845	C6	8889	Capacitor, Film TDY-1H-104	AAT 41244
R41	000149	Resistor, Carbon 2.7M ohm 1/4W ± 5%	AAT 51847	C7	025027	Capacitor, Ceramic DT-203 180P	AAT 41324
R42	000151	Resistor, Carbon 3.3M ohm 1/4W ± 5%	AAT 51849	C8	88153	Capacitor, Tantalum SSG25-1F	AAT 41425
R43	000172	Resistor, Carbon 47M ohm 1/4W ± 5%	AAT 51853	C9	88154	Capacitor, Tantalum SSG25-4R7F	AAT 41428
R44	000095	Resistor, Carbon 15K ohm 1/4W ± 5%	AAT 51968	C10	88155	Capacitor, Tantalum SSG25-10F	AAT 41430
R45	000102	Resistor, Carbon 30K ohm 1/4W ± 5%	AAT 51969	C11	88156	Capacitor, Tantalum SSG25-0R1F	AAT 41431
R46	000139	Resistor, Carbon 1M ohm 1/4W ± 5%	AAT 51971	R1	001090	Resistor, Carbon 100K ohm 1/2W ± 5%	AAT 51455
VR1	88149	Variable Resistor B-50K	AAT 53047	R2	000091	Resistor, Carbon 10K ohm 1/4W ± 5%	AAT 51717
RB	997631	Resistor Block Lk-8 elements	AAT 55036	R3	000115	Resistor, Carbon 100K ohm 1/4W ± 5%	AAT 51741
VR2	88149	Variable Resistor B-50K	AAT 53041	R4	000123	Resistor, 220K ohm 1/4W ± 5%	AAT 51749
IC33	076119	LS - IC 74LS367	AAT 33203	R5	000125	Resistor, 270K ohm 1/4W ± 5%	AAT 51751
IC34	076129	LS - IC 74LS393	AAT 33220	R6	000129	Resistor, 390K ohm 1/4W ± 5%	AAT 51755
CPU	077002	CPU 2-80A	AAT 34008	R7	000131	Resistor, 470K ohm 1/4W ± 5%	AAT 51757
IC35	88123	C-MOS MC14584	AAT 36105	R8	000067	Resistor, 1K ohm 1/4W ± 5%	AAT 51765
IC36	88124	Custom IC PC3259	AAT 37003	R9	000074	Resistor, 2K ohm 1/4W ± 5%	AAT 51772
				R10	000099	Resistor, 22K ohm 1/4W ± 5%	AAT 51773

SOUND PC BOARD**FIGURE 21**

ITEM	TAITO PART NO.	DESCRIPTION	REFERENCE
R11	000079	Resistor, 3.3K ohm $\frac{1}{4}W \pm 5\%$	AAT 51777
R12	000083	Resistor, Carbon 4.7K ohm $\frac{1}{4}W \pm 5\%$	AAT 51781
R13	000091	Resistor, Carbon 10K ohm $\frac{1}{4}W \pm 5\%$	AAT 51789
R14	000099	Resistor, Carbon 22K ohm $\frac{1}{4}W \pm 5\%$	AAT 51797
R15	000101	Resistor, Carbon 27K ohm $\frac{1}{4}W \pm 5\%$	AAT 51799
R16	000107	Resistor, Carbon 47K ohm $\frac{1}{4}W \pm 5\%$	AAT 51805
R17	000129	Resistor, Carbon 390K ohm $\frac{1}{4}W \pm 5\%$	AAT 51827
R18	000133	Resistor, Carbon 560K ohm $\frac{1}{4}W \pm 5\%$	AAT 51831
R19	000139	Resistor, Carbon 1M ohm $\frac{1}{4}W \pm 5\%$	AAT 51837
VR	88157	Variable Resistor, B-2K	AAT 53030
RB	997631	Resistor Block, 1 ohm 8 elements	AAT 55036

CPU BOARD SCHEMATIC 1 OF 7

FIGURE 22

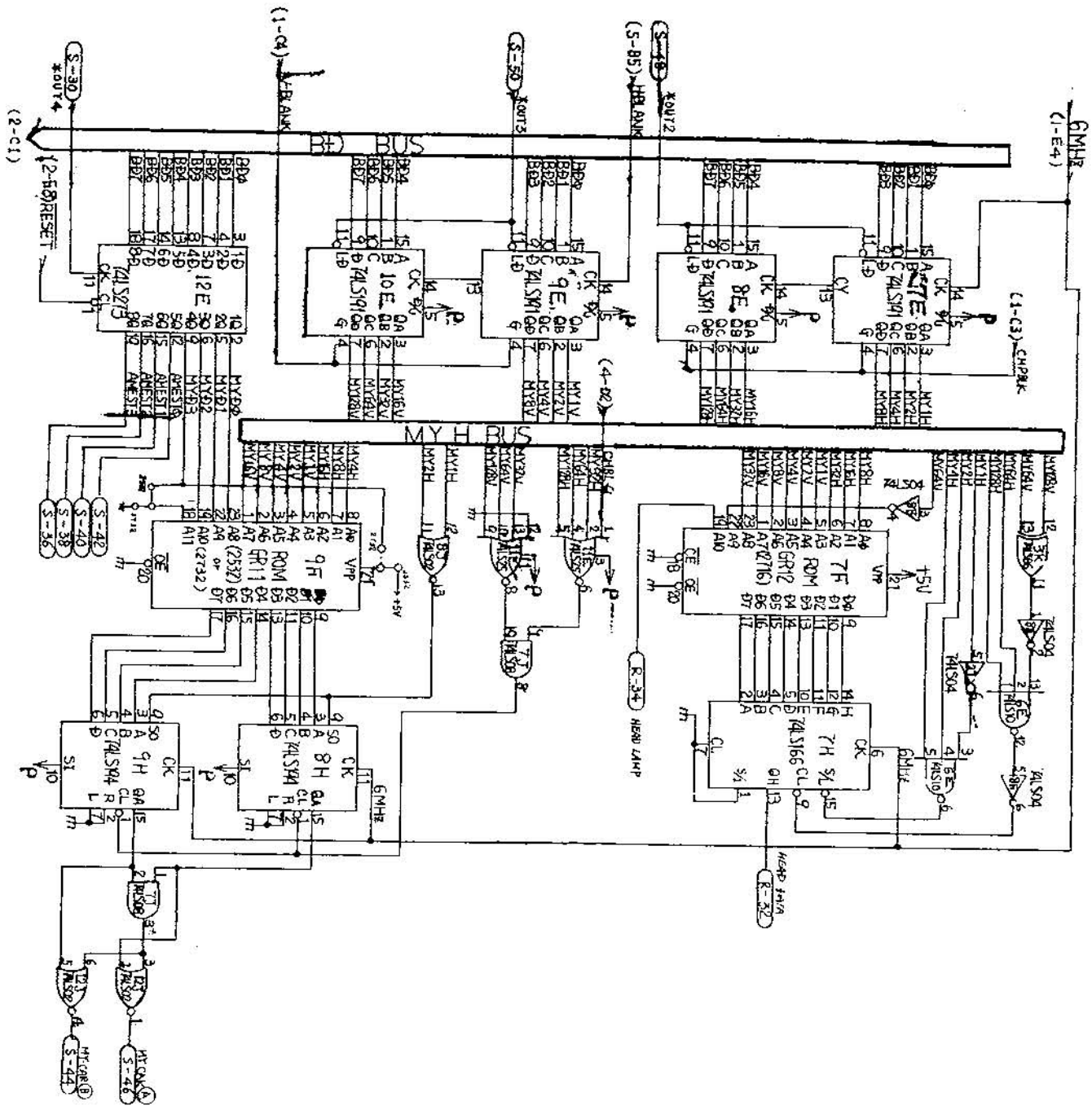

CPU BOARD SCHEMATIC 2 OF 7

FIGURE 23

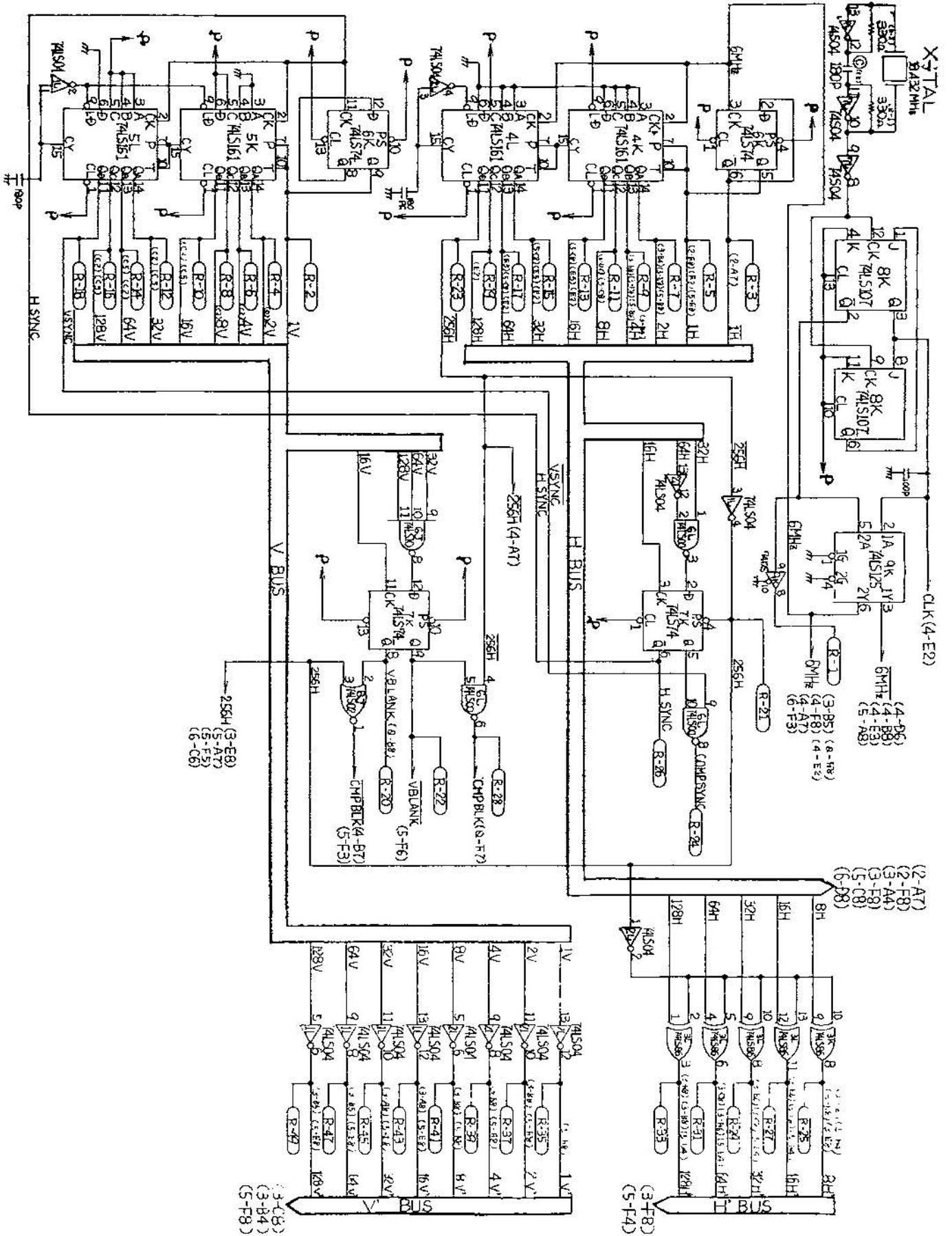

CPU BOARD SCHEMATIC 3 OF 7

FIGURE 24

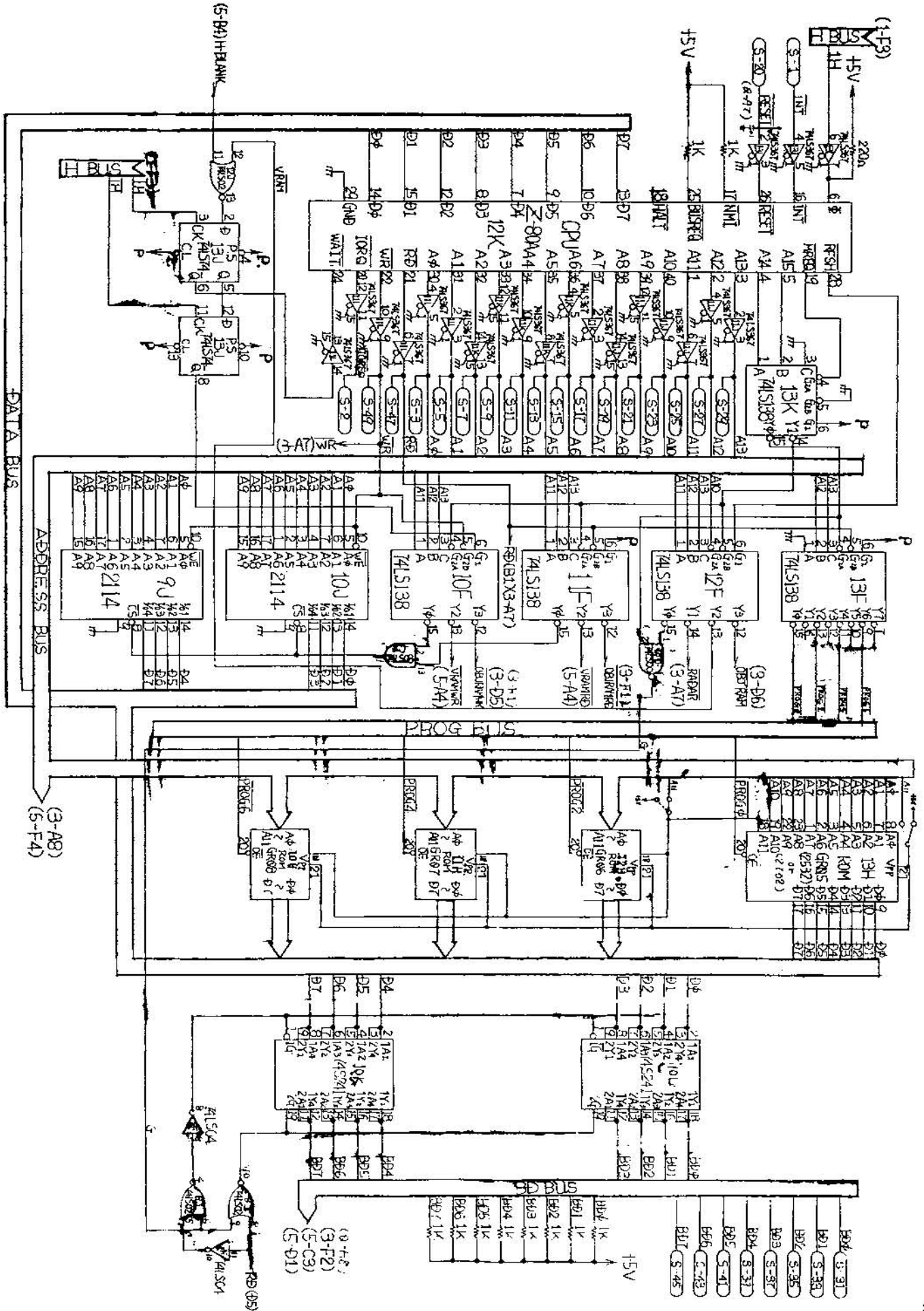

CPU BOARD SCHEMATIC 5 OF 7

FIGURE 26

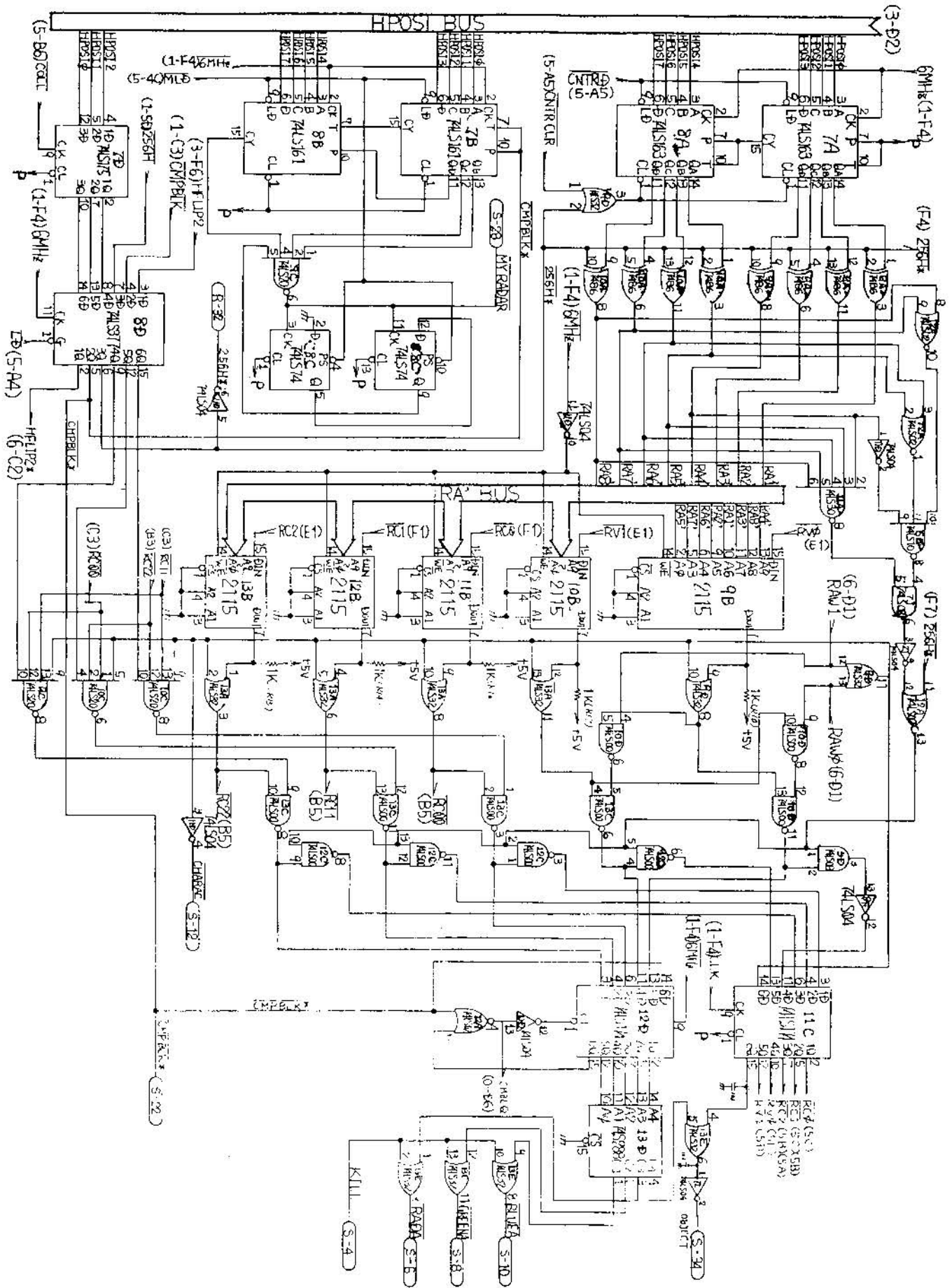

CPU BOARD SCHEMATIC 6 OF 7

FIGURE 27

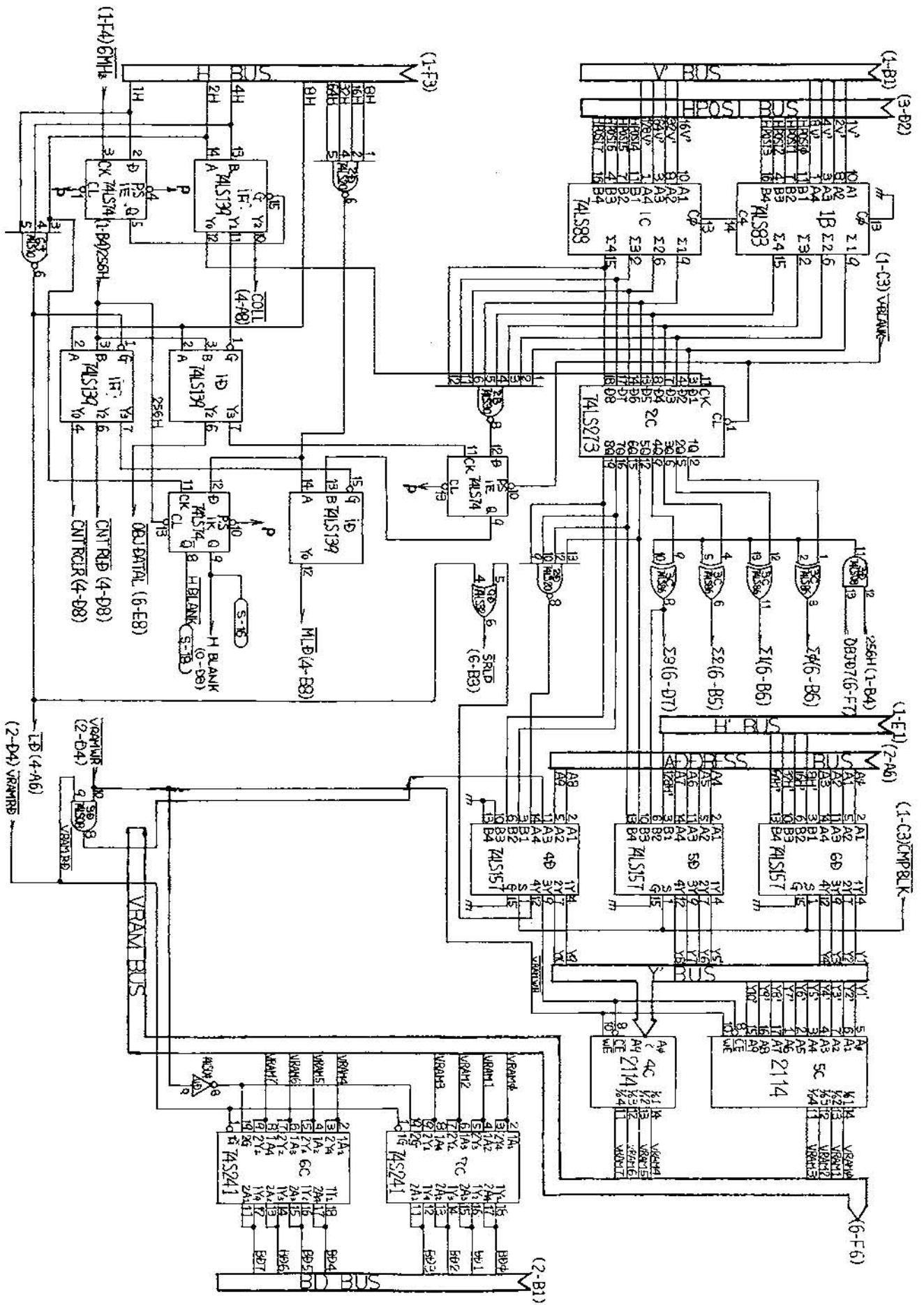

GAME BOARD SCHEMATIC 1 OF 10

FIGURE 29

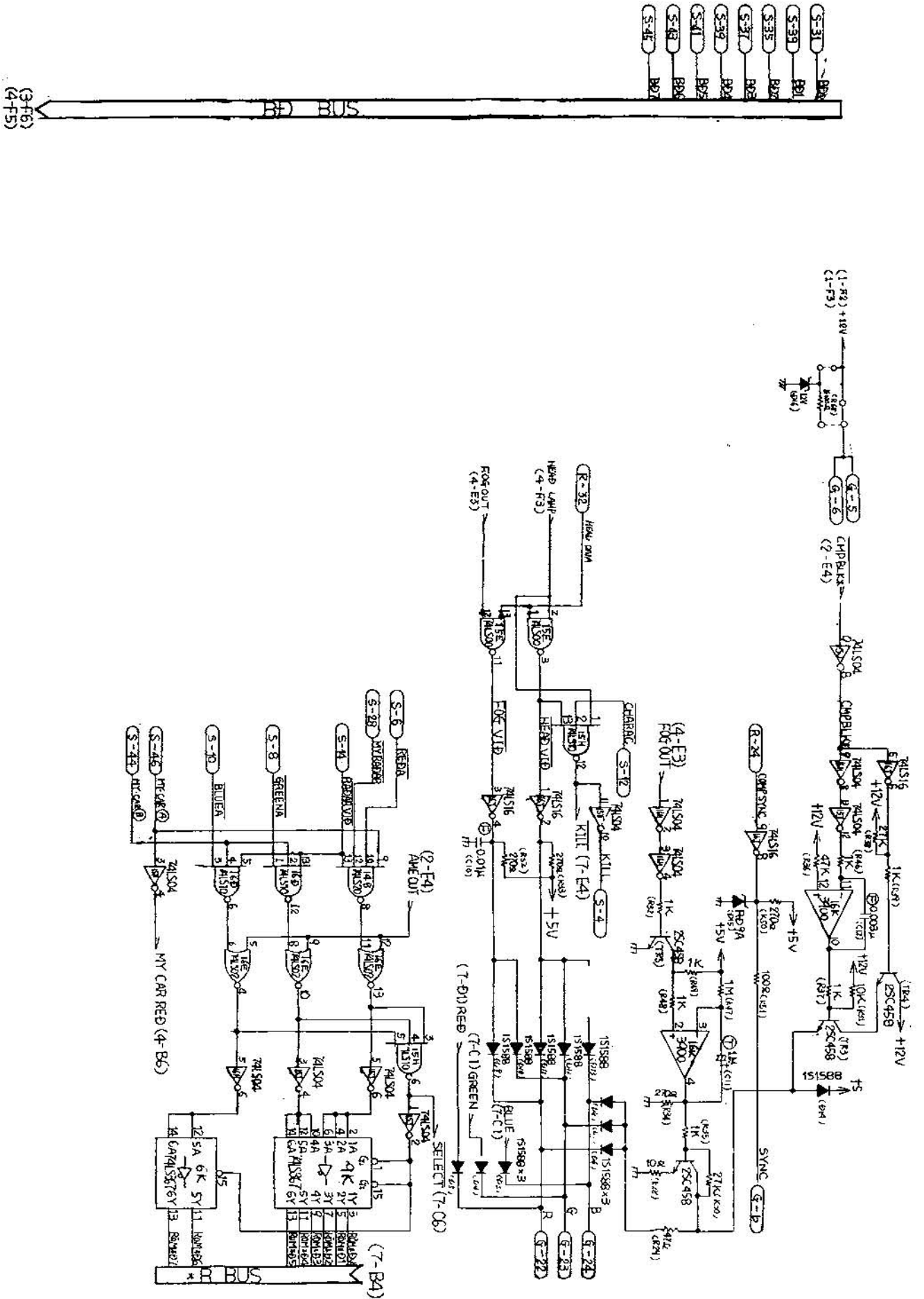

GAME BOARD SCHEMATIC 2 OF 10

FIGURE 30

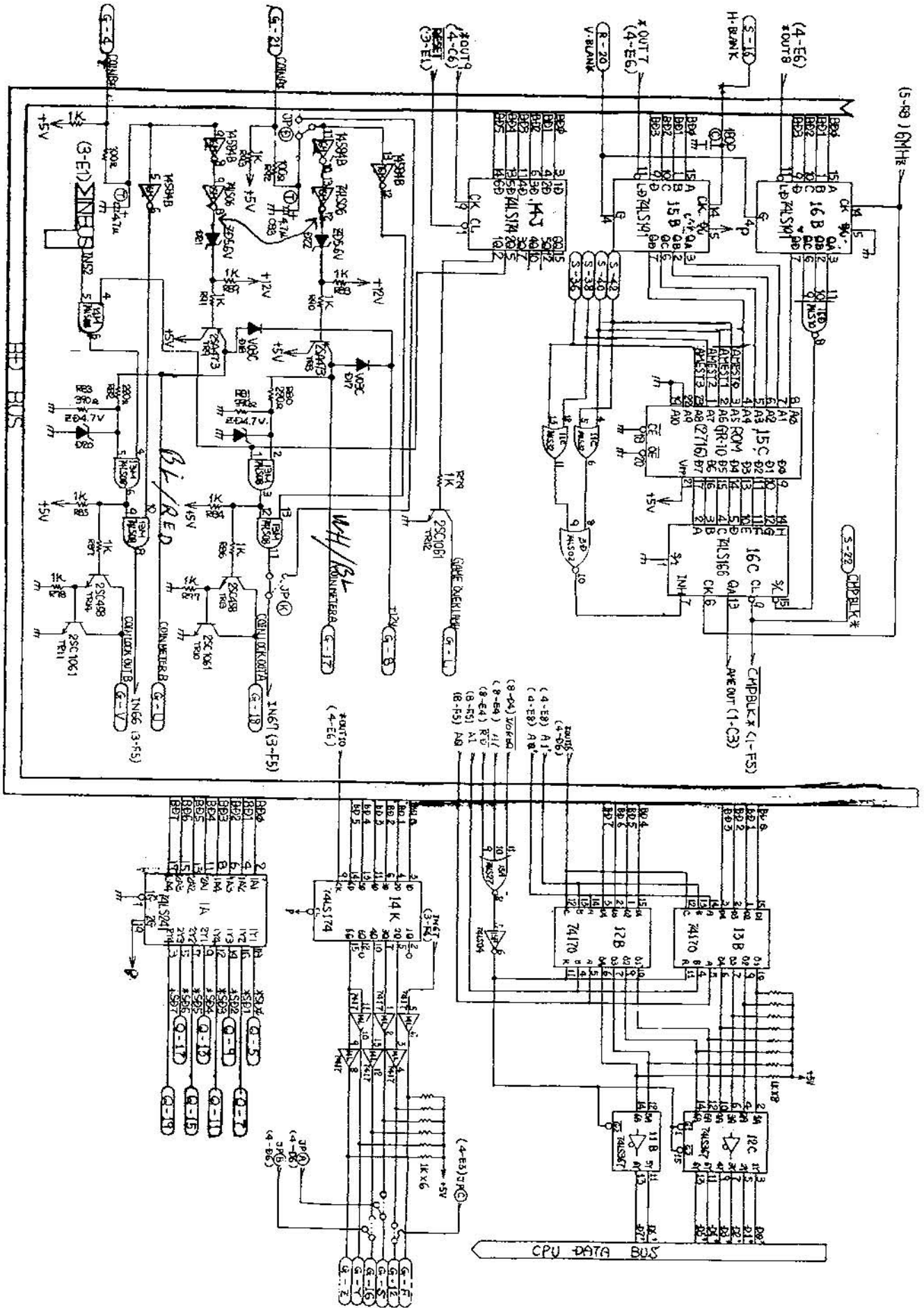

GAME BOARD SCHEMATIC 3 OF 10

FIGURE 31

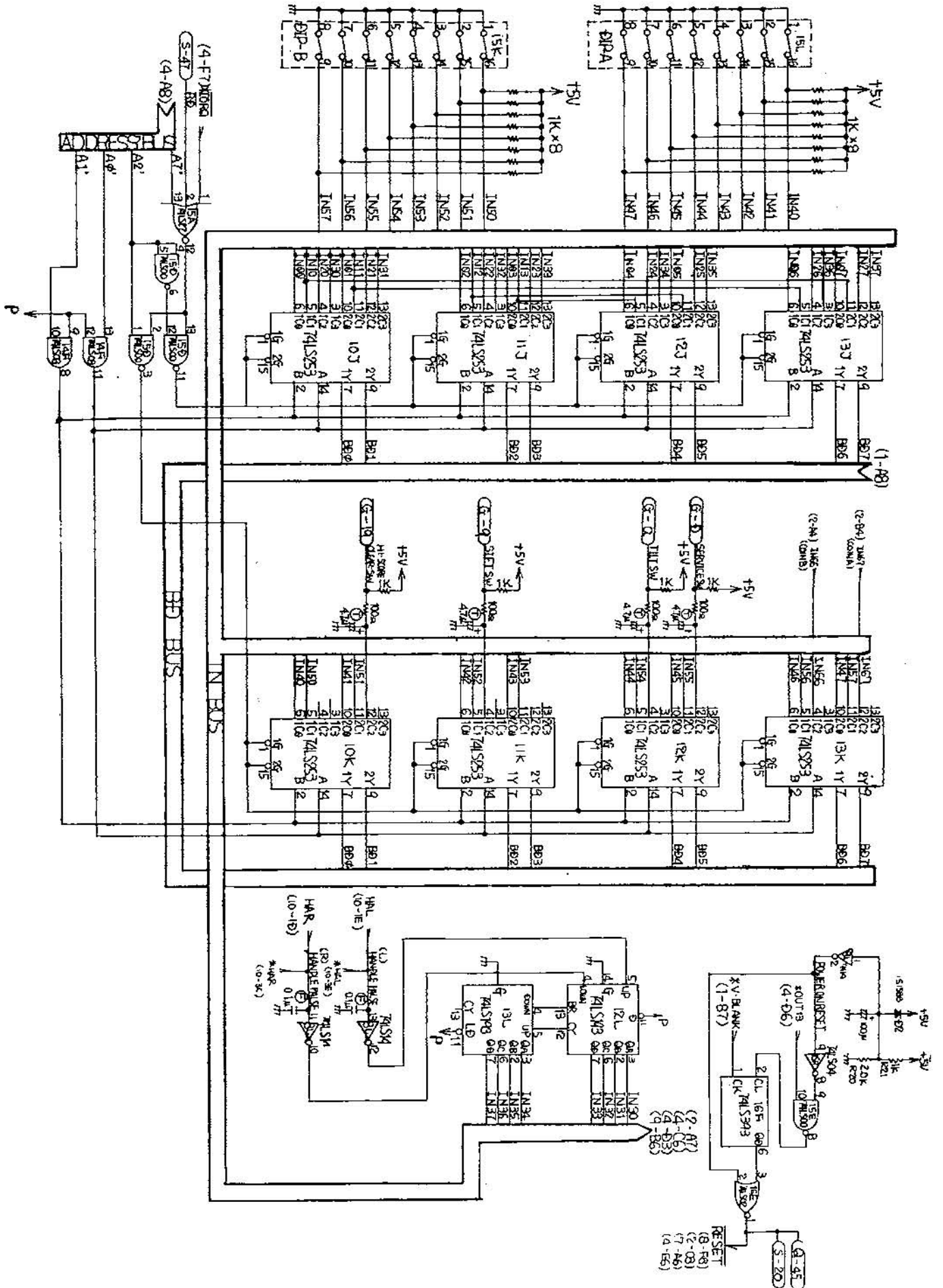
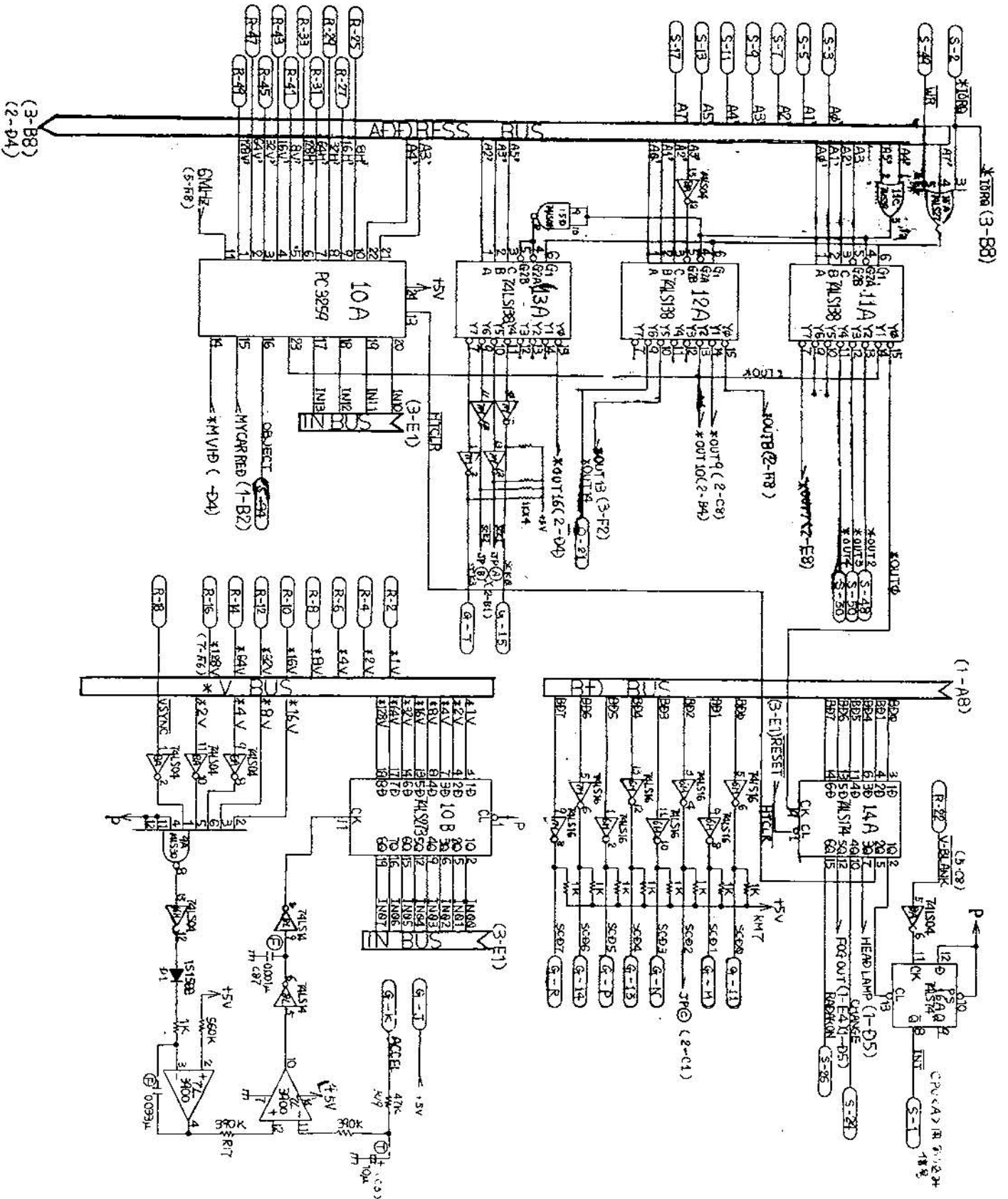
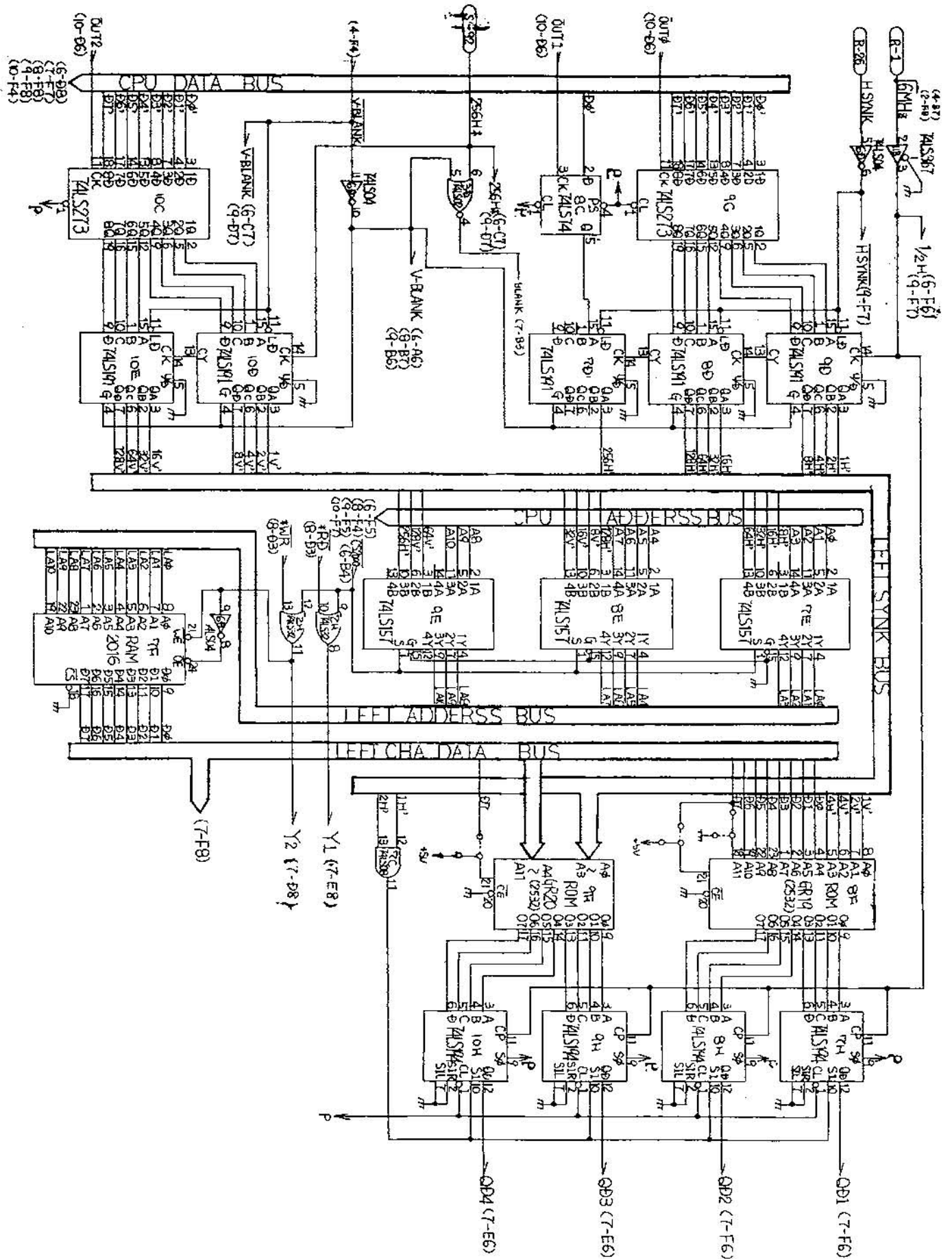

FIGURE 32



GAME BOARD SCHEMATIC 5 OF 10

FIGURE 33



GAME BOARD SCHEMATIC 6 OF 10

FIGURE 34

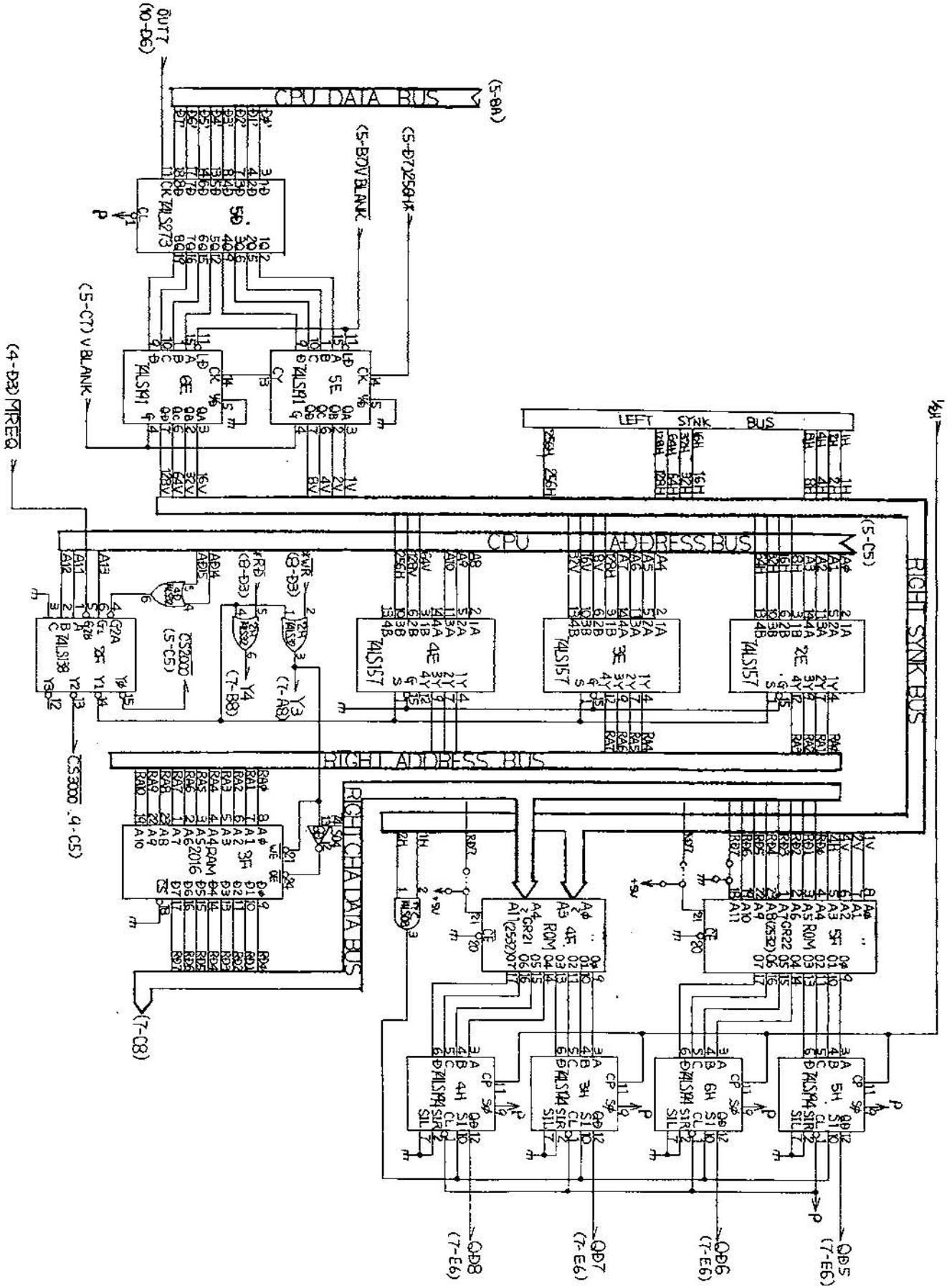

GAME BOARD SCHEMATIC 7 OF 10

FIGURE 35

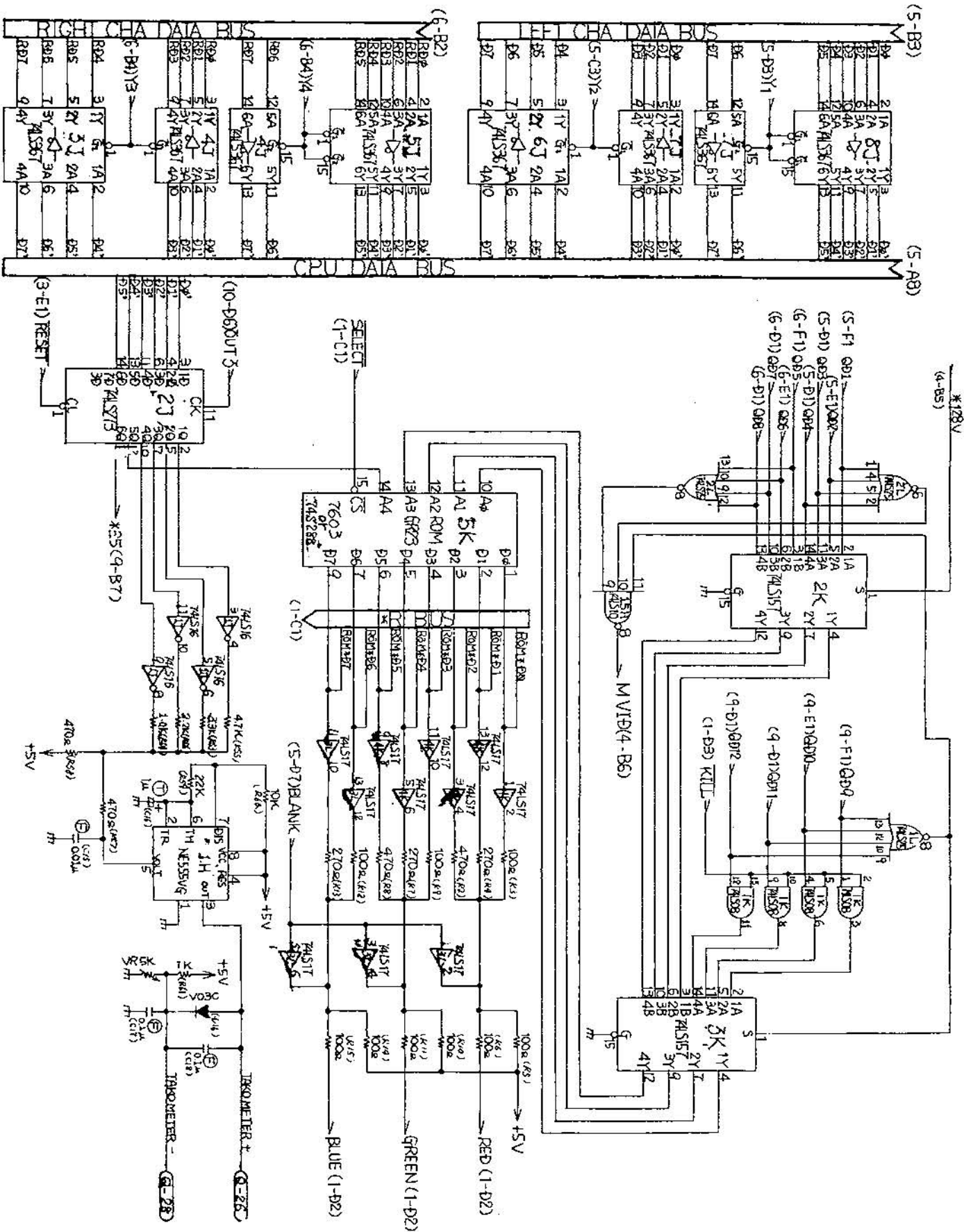

GAME BOARD SCHEMATIC 8 OF 10

FIGURE 36

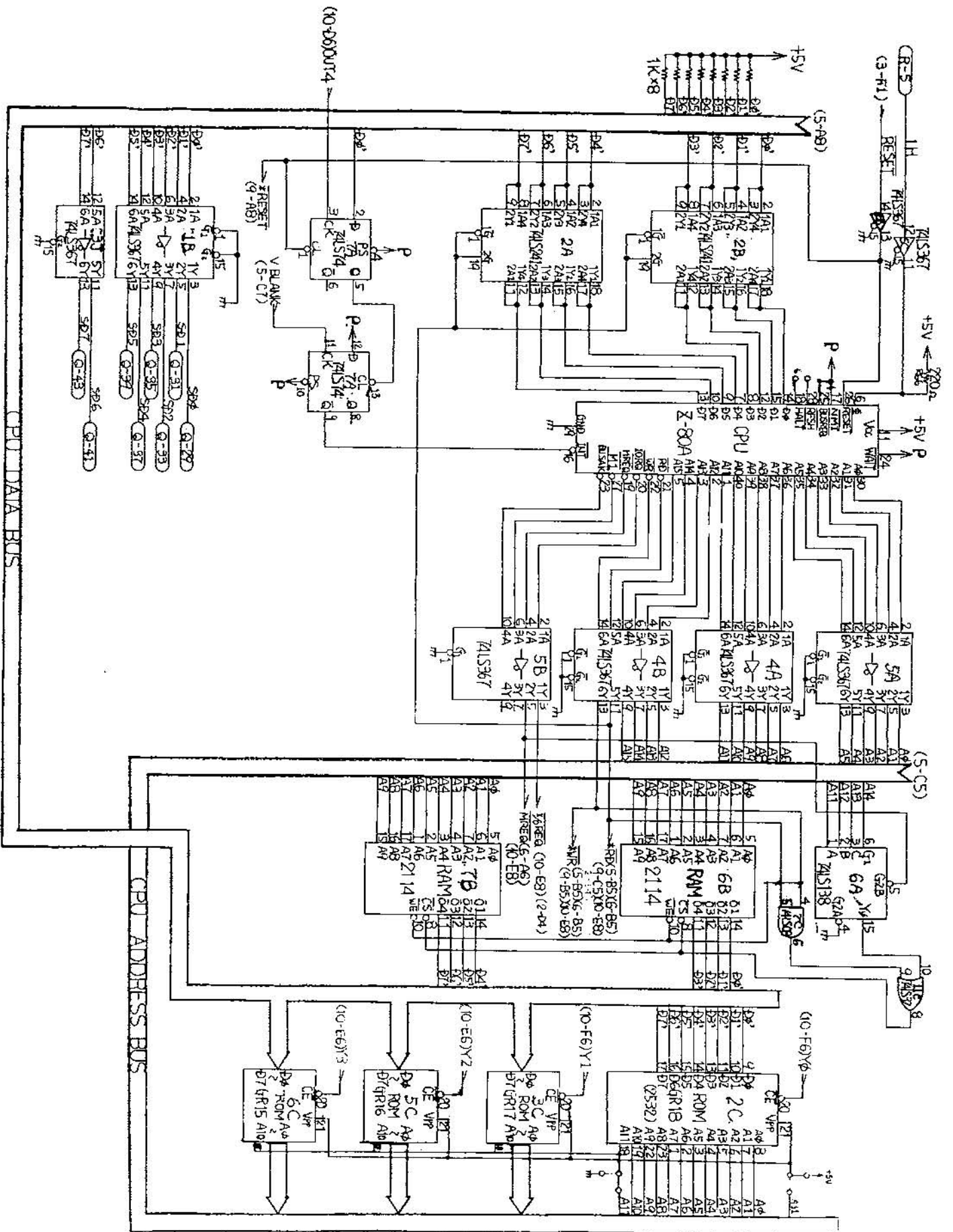

GAME BOARD SCHEMATIC 9 OF 10

FIGURE 37

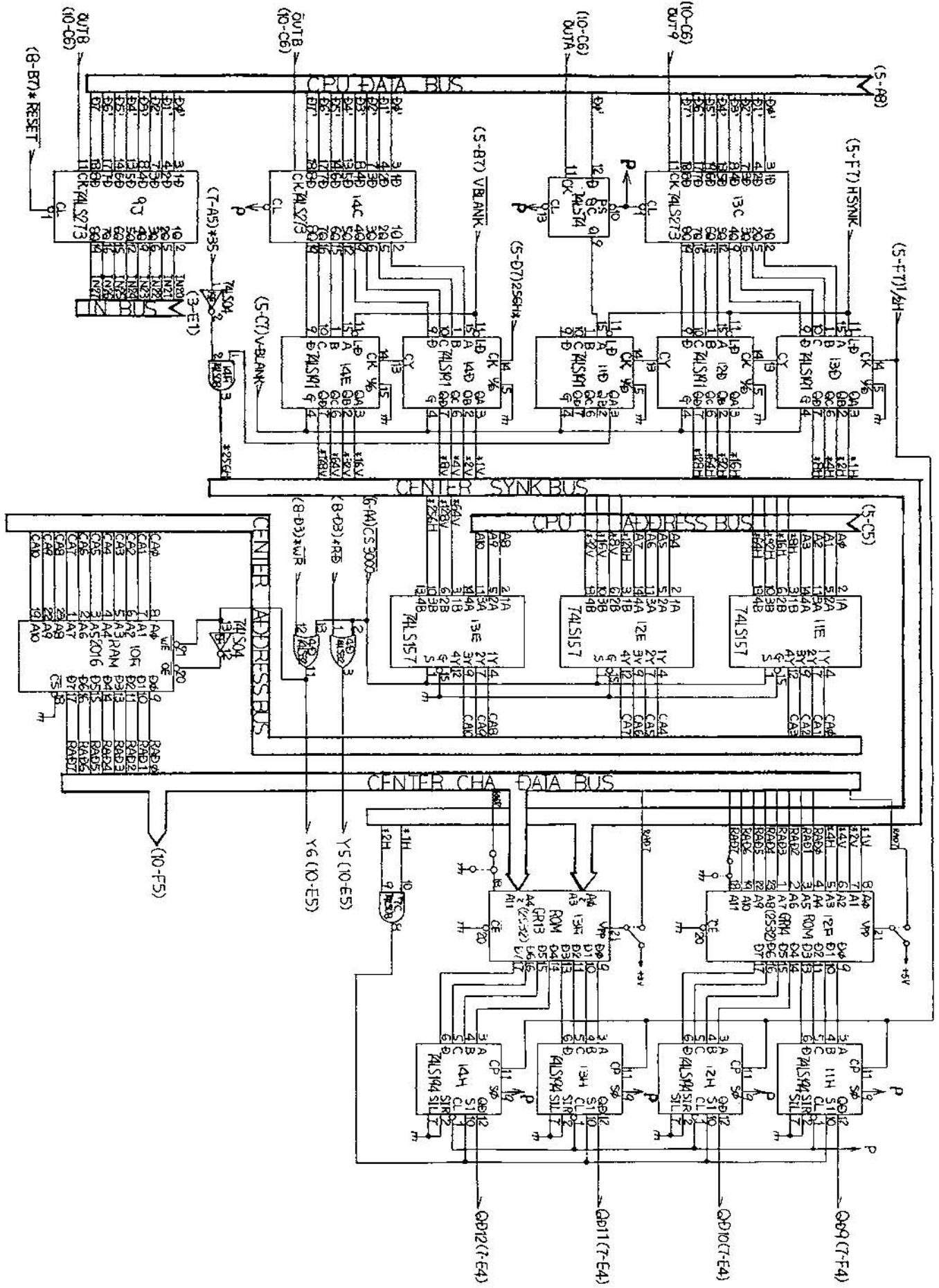

GAME BOARD SCHEMATIC 10 OF 10

FIGURE 38

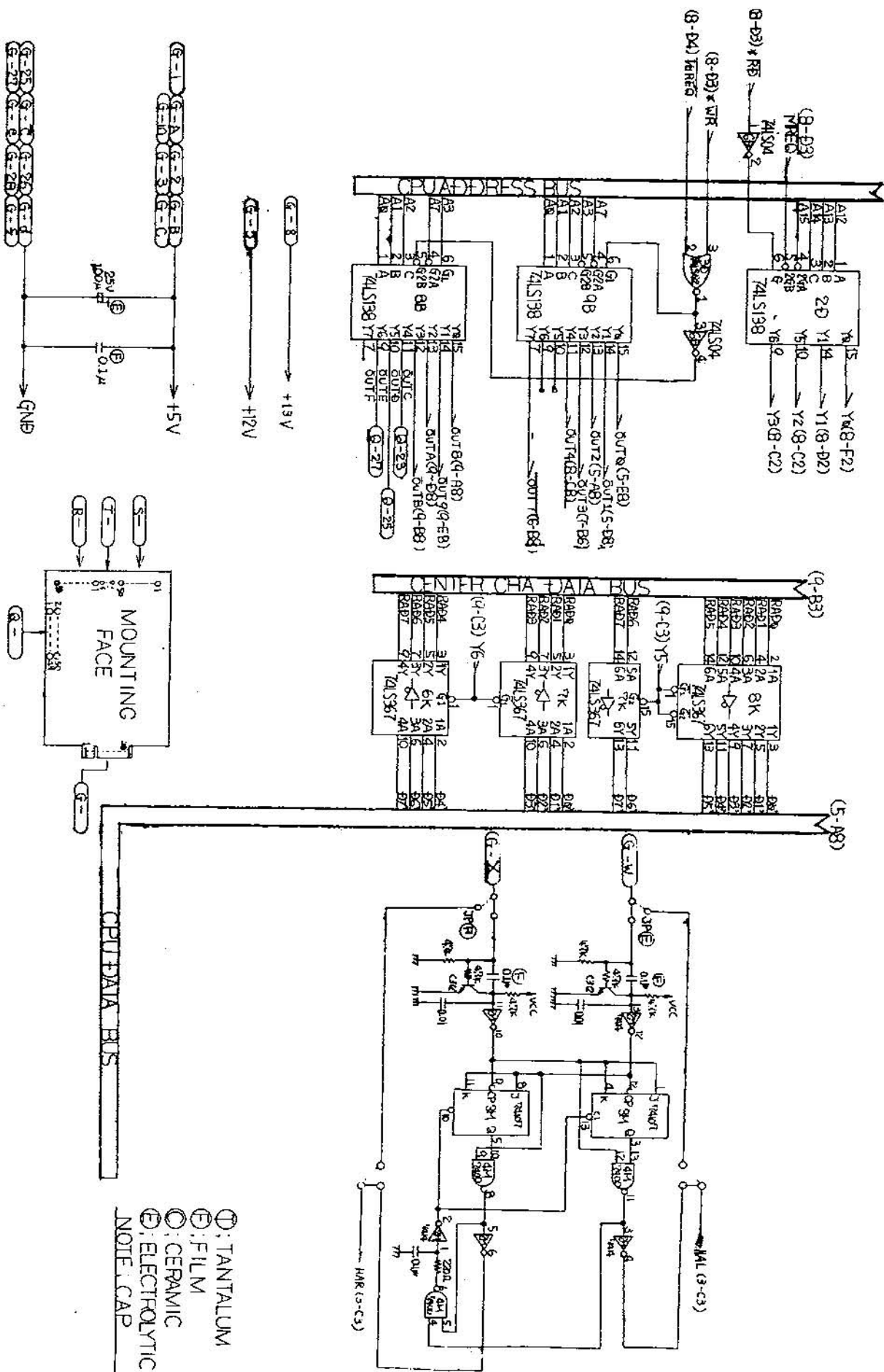

SOUND BOARD SCHEMATIC 1 OF 5

FIGURE 39

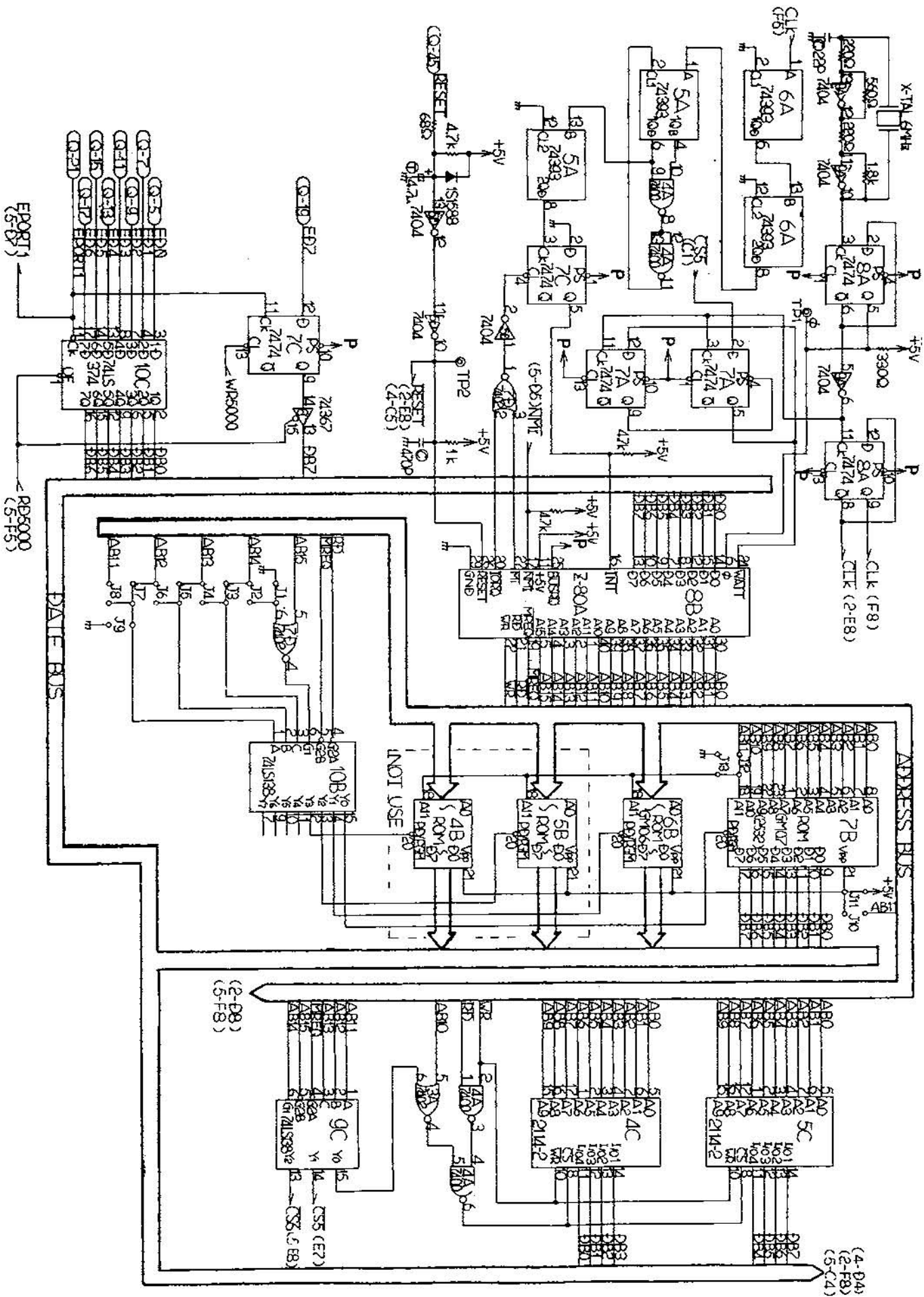

SOUND BOARD SCHEMATIC 2 OF 5

FIGURE 40

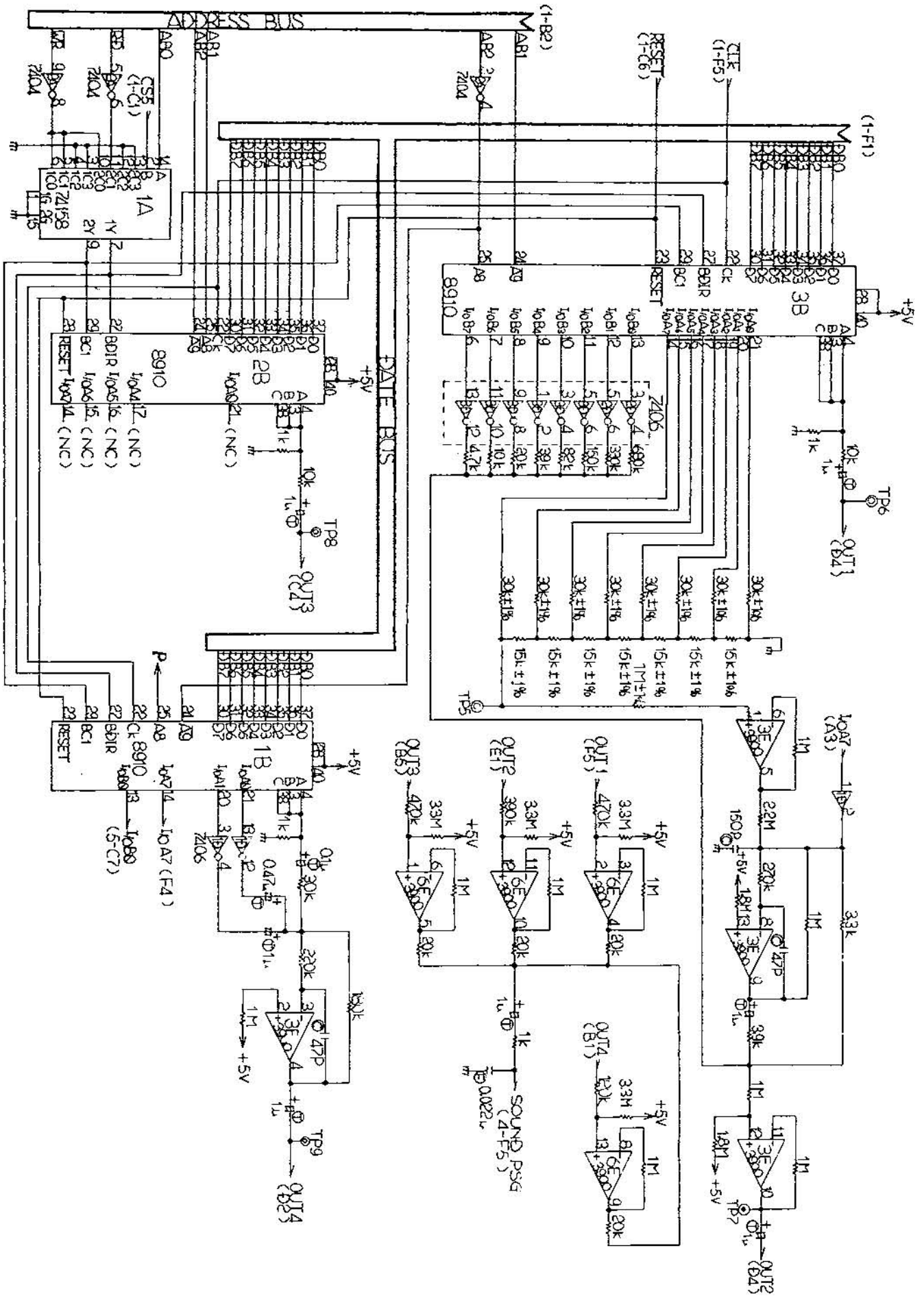

SOUND BOARD SCHEMATIC 3 OF 5

FIGURE 41

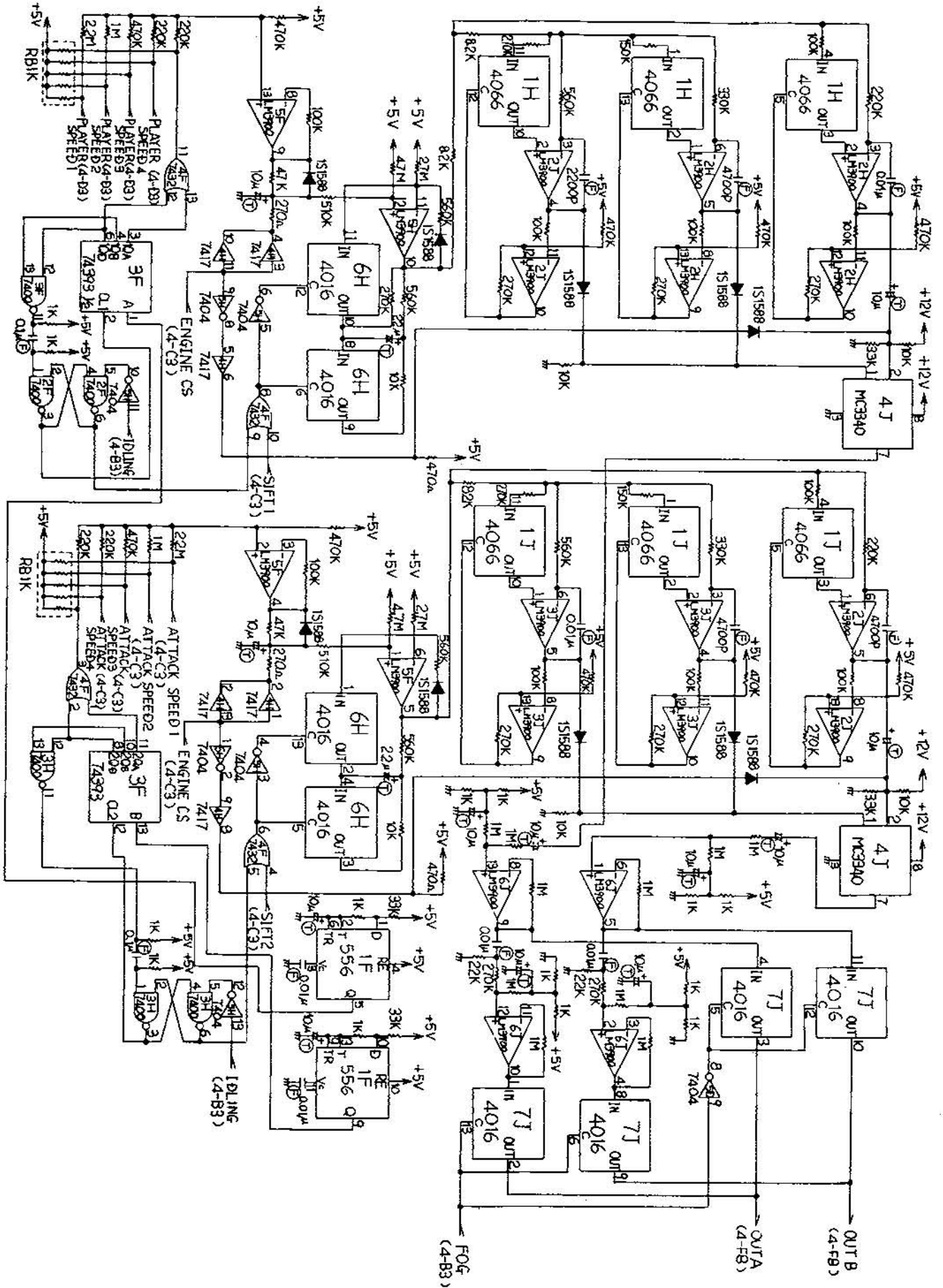

SOUND BOARD SCHEMATIC 5 OF 5

FIGURE 43

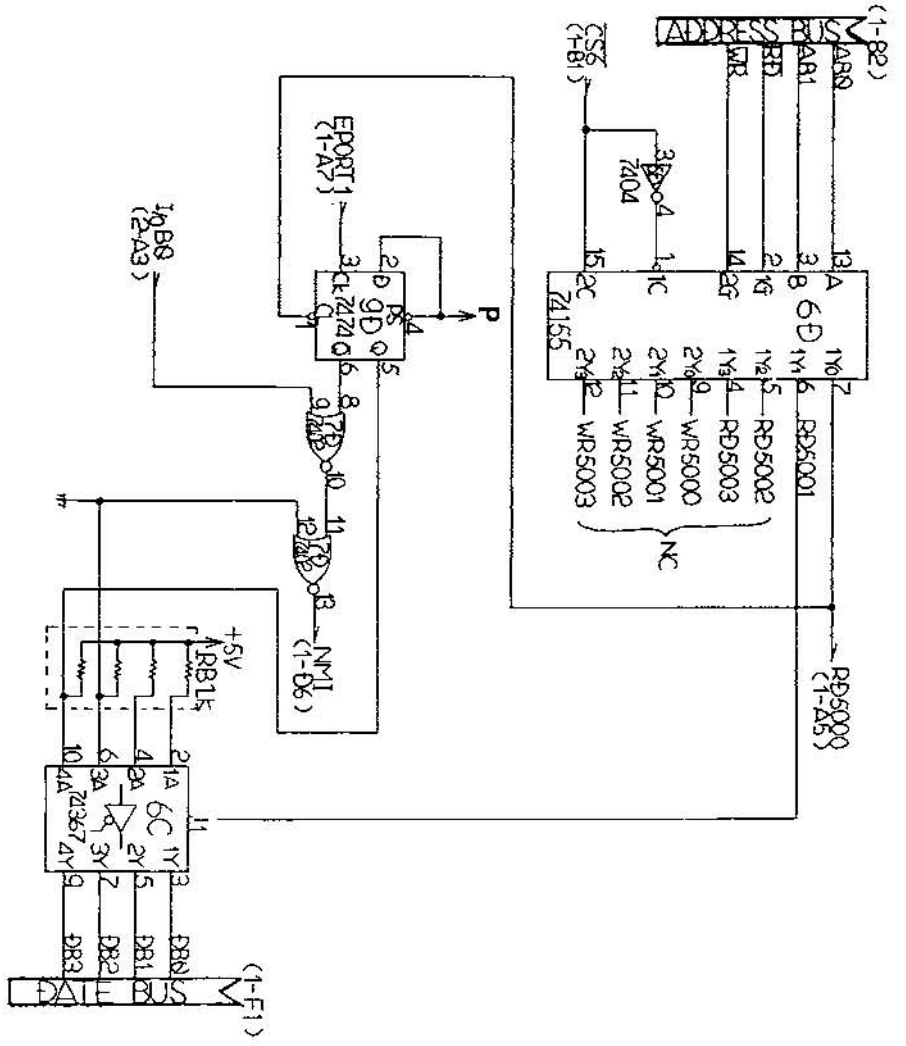

- Ⓜ: FILM
 - Ⓞ: CERAMIC
 - Ⓣ: TANTALUM
 - Ⓟ: ELECTROLYTIC
- NOTE: CAP.

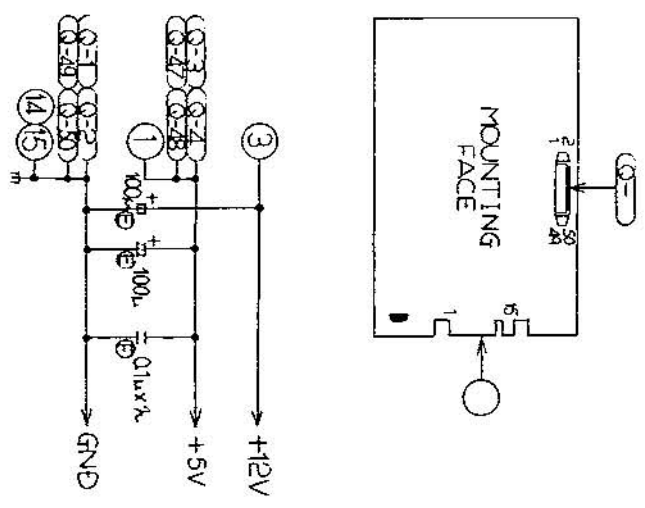

TIME & SCORE PC BOARD SCHEMATIC 1 OF 2

FIGURE 44

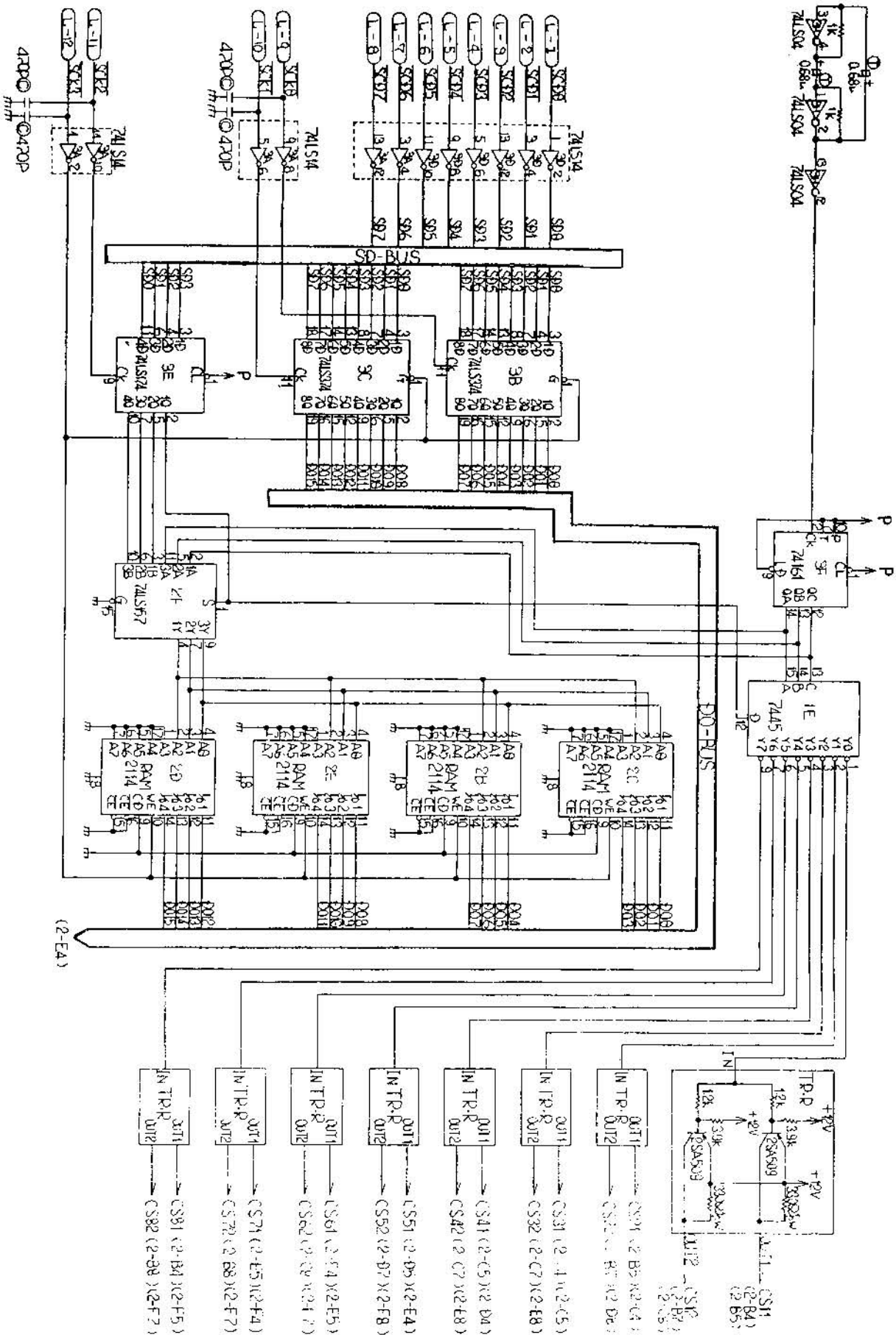

TIME & SCORE PC BOARD SCHEMATIC 2 OF 2

FIGURE 45

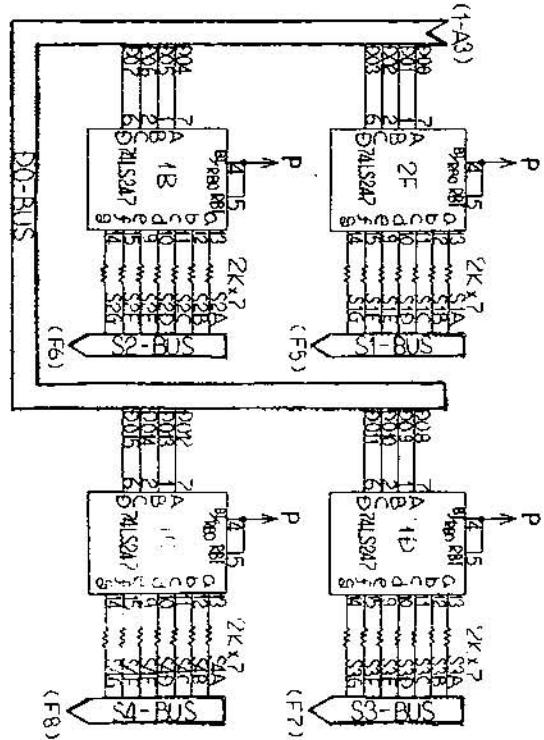
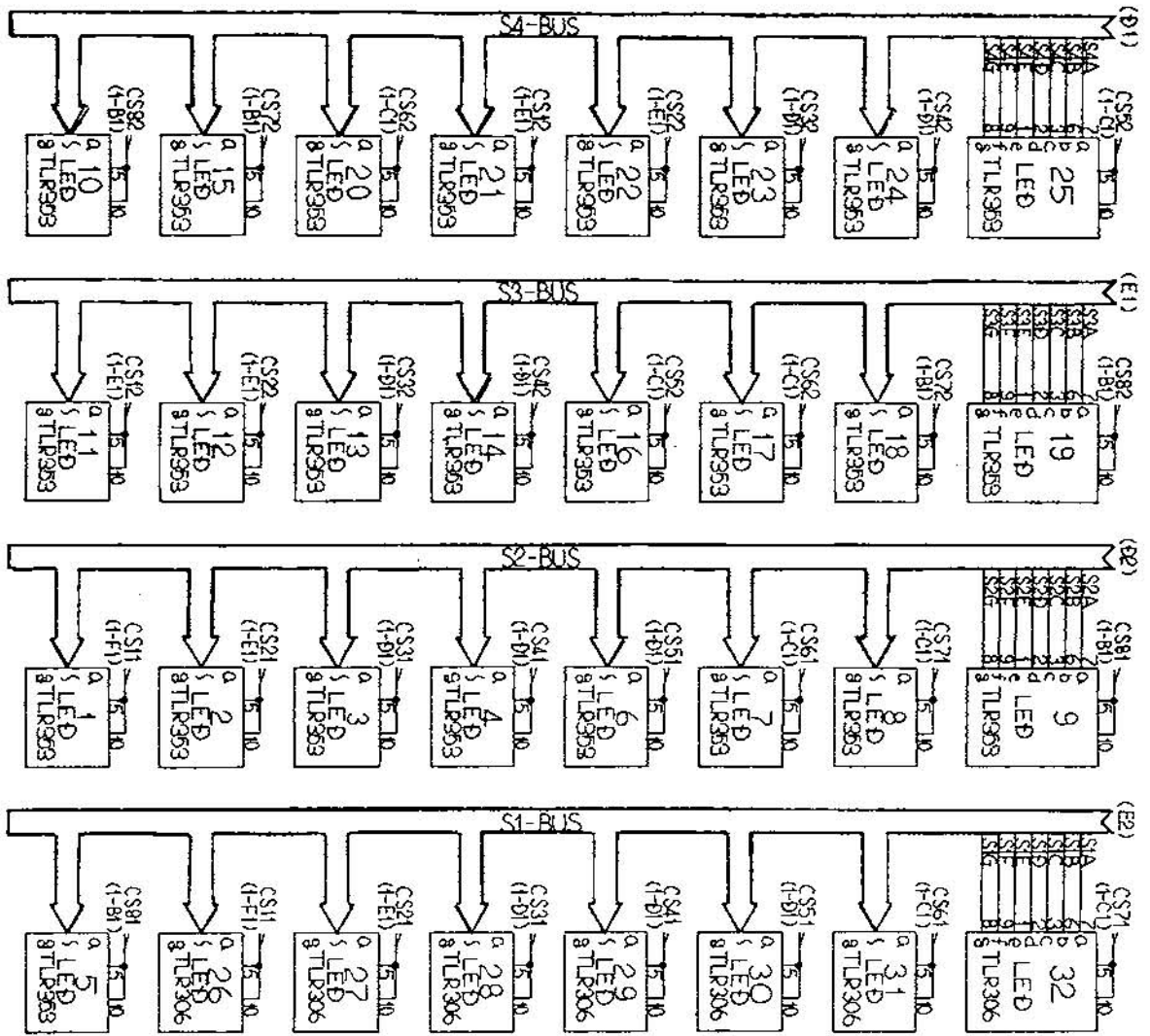

⊖ : FILM
 ⊕ : TANTALUM
 NOTE: CAP

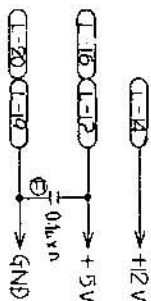
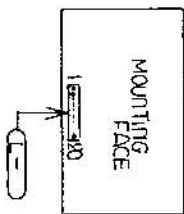

WIRING DIAGRAM

FIGURE 46

