



## OPERATOR'S MANUAL

2nd EDITION



© GAELCO 2003

IT IS THE RESPONSIBILITY OF THE OPERATOR TO CARE ABOUT COSTUMER SAFETY AT ALL TIMES. PLEASE READ AND OBSERVE THE NOTES ON SAFETY DESCRIBED IN THIS MANUAL.

## About TOKYOCOP

---

Thank you for purchasing a Gaelco's product. This manual explains how to safely operate your TOKYOCOP® machine. Failing to operate the machine correctly could result in malfunction or accident, so please read the manual carefully before starting operation, specially the SAFETY NOTES (Section 3).

Unauthorised reproduction of this document or any of its contents is strictly forbidden, without permission from Gaelco S.A.

Note: Operator's Manual Specifications are subject to change without prior notice

© 2003 Gaelco S.A. - All rights reserved

Copyright law and industrial property law protect the contents of this game, its main data and design.



**TOKYOCOP® has been manufactured in accordance with European Community directives. Any changes or modifications to this machine has to be authorised by Gaelco S.A. and must be in accordance with the CE directives.**

**Using spear parts that do not fit specifications will void the warranty. Removal of serial numbers and/or bar codes from product or components will void the warranty.**

Published by:  
GAELCO S.A.  
Escipión 11  
08023 Barcelona - SPAIN  
Tel. ++34 93 417 36 26  
Fax ++34 93 417 28 02  
e-mail gaelco@gaelco.com  
web www.gaelco.es

### FCC Notice

This equipment has been tested and found to comply with the limits for a Class A digital device, pursuant to Part A of the FCC Rules. These limits are designed to provide reasonable protection against harmful interference when the equipment is operating in a commercial environment. This equipment uses, and can radiate radio frequency energy, if not installed and used according to the instruction manual, and may cause harmful interference to radio communications.

Operation of this equipment in a residential area is likely to cause harmful interference in which case the user will be required to correct the interference at his own expense.

INDEX

---

- 1. GENERAL INFORMATION**
  - 1.1 Manufacturer and Machine data
  - 1.2 Legislation references
  - 1.3 Technical Service
  - 1.4 Responsibility
- 2. MACHINE SPECIFICATIONS**
- 3. SAFETY NOTES**
  - 3.1 General considerations
  - 3.2 Location
  - 3.3 Moving the machine
  - 3.4 Operation
  - 3.5 Motion system
- 4. MATERIAL HANDLING**
  - 4.1 Transport of the packaged units
  - 4.2 Storage
  - 4.3 Reception
- 5. UNPACKING, ASSEMBLING AND INSTALLATION**
  - 5.1 Inspection before assembling
  - 5.2 Assembling
  - 5.3 Installation
  - 5.4 Switching on the machine
- 6. TEST MODE AND PROGRAMMATION**
  - 6.1 Screen test
  - 6.2 Controls test
  - 6.3 Motion System test
  - 6.4 Settings
  - 6.5 Link settings
  - 6.6 Sound test
  - 6.7 Book Keeping
  - 6.8 Exit
- 7. HOW TO PLAY**
  - 7.1 Competition on link mode
- 8. HOW TO LINK TWO MACHINES**
- 9. TECHNICAL SERVICE**
  - 9.1 Prior considerations
  - 9.2 Safety precautions
  - 9.3 Motion system - Block diagram
  - 9.4 Emergency stop
  - 9.5 Position potentiometers
  - 9.6 Commander SE parameters
  - 9.7 Troubleshooting
- 10. PARTS LIST**
  - General index
  - MONITOR CABINET.**
    - 10.1 Accessories
    - 10.2 Subwoofer parts
    - 10.3 Union harness assembly
    - 10.4 Billboard assembly
    - 10.5 Rear accesories
    - 10.6 Monitor and front door
    - 10.7 Electronic parts 1
    - 10.8 Electronic parts 2
    - 10.9 Bottom parts
  - PLATFORM**
    - 10.10 Main assemblies
    - 10.11 Dashboard assembly - 1
    - 10.12 Dashboard assembly - 2
    - 10.13 Steering assembly
    - 10.14 Pedals assembly
    - 10.15 Seat assemby
    - 10.16 Mobile platform assembly
    - 10.17 Base assembly
    - 10.18 Motor assembly
    - 10.19 Tower assembly
- 11. WIRING DIAGRAMS**
- 12. CREDIT DISTRIBUTOR SETUP**



## 1. GENERAL INFORMATION

### 1.1 MANUFACTURER AND MACHINE DATA

---

Manufacturer	GAELCO, S.A.
Address	Escipión 11
ZIP	08023
City	Barcelona
Country :	SPAIN
Tel.	34 93 417 36 26
Fax	34 93 417 28 02
e-mail	gaelco@gaelco.com
Technical Service	sat@gaelco.com

Name of the game	TOKYOCOP®
Model	MOTION

### 1.2 LEGISLATION REFERENCES

---

#### EM EMISSION

- EN 61000-3-2 (1995), Harmonics
- EN 61000-3-3 (1995), Fluctuations
- EN 55022 (1994), Continuous conducted emission (Class A)
- EN 55022 (1994), Radiated emission (Class A)

#### EM IMMUNITY

- EN 61000-4-2 (1995), ESD
- EN 61000-4-3 (1996) & ENV 50204 (1995), Radiated field of RF
- EN 61000-4-4 (1995), EFT burst
- EN 61000-4-5 (1995), Surges
- EN 61000-4-6 (1996), RF common mode
- EN 61000-4-8 (1993), 50 Hz H-field
- EN 61000-4-11 (1994), Dips, interruptions

#### ELECTRICAL SAFETY

UNE EN 60335-1 (1997) + Erratum (1997) + A11 (1997) + A12 (1997) + A13 (1999) + A14 (1999) + Erratum (1999).

Note: Test passed in Motion Test mode

### 1.3 TECHNICAL SERVICE

---

Gaelco S.A. or its Distributors carry out technical service.

### 1.4 RESPONSIBILITY

---

Any modifications made to this machine that are not authorised in writing by the manufacturer will be considered to be at the exclusive responsibility of the operator, who will consequently become the new "manufacturer" and must operate in compliance with the European Community directives.

In case of an accident caused by a defective part, the manufacturer will assume responsibility only if the machine was defective in its original condition. However, this responsibility shall be diminished or even totally annulled if the operator or the player do not follow the instructions provided or if the operator uses spare parts that are not covered by guarantee, are not authorised in writing or do not correspond to the specified technical characteristics.

## 2. SPECIFICATIONS

### GAME DESCRIPTION

---

TOKYOCOP® is a "catch me if you can" game. The player drives a police car and patrols the streets of Tokyo. The goal is to capture as many criminals as possible within the span of time allowed by the machine. As the criminals drive crazy and have fast cars, the chase turns in a frantic urban race. There's an interactive driving feedback with 2DOF motion that delivers very realistic sensations to the player. Furthermore, the chase takes place in an open circuit, so each game is a new experience plenty of surprises.

Two players can also compete one against each other when the machines are linked.

### DIMENSIONS AND WEIGHT

1) Crate dimensions and shipping weight of each module

	width	depth	height	weight
<b>Monitor cabinet</b>	<b>1000 mm</b>	<b>800 mm</b>	<b>1935 mm</b>	<b>205 Kg</b>
<b>Platform</b>	<b>1000 mm</b>	<b>1500 mm</b>	<b>1538 mm</b>	<b>325 Kg</b>

2) Dimensions and net weight of each module unpacked

	width	depth	height	weight
<b>Monitor cabinet</b>	<b>831 mm</b>	<b>730 mm</b>	<b>2164 mm*</b>	<b>190 Kg</b>
<b>Platform</b>	<b>880 mm</b>	<b>1490 mm</b>	<b>1368 mm</b>	<b>310 Kg</b>

\* With the billboard

3) Total dimensions of the machine, installed on site

width	depth	height
1513 mm	2463 mm	2164 mm

**POWER SUPPLY**

Operating Power: 220-230 VAC, 50 Hz  
Output: +5VDC 20A, +12VDC 8A

**MONITOR**

34" Hantarex Polo/2 STAR PH, code 01297790

**CPU BOARD**

PCB Gaelco TOKYOCOP

**CONTROLS**

- Interactive steering wheel
- Start button (placed in the centre of the steering wheel)
- View button (placed on the dashboard)
- Siren button (placed on the dashboard)
- Accelerator pedal
- Brake pedal
- Emergency Stop button (placed on top of the coin tower)

**MOTION SYSTEM**

Degrees of freedom: 2 DOF  
Actuators: 2 induction motors (geared), 0.75KW each  
Control: 2 frequency inverters SE1120075, input voltage 230V +/-10%, 50/60Hz

**ATTACHMENTS**

- Operator's Manual (1)
- Motor driver manual (1)
- Monitor Manual (1)
- Coin box keys (2)
- Monitor cabinet keys (3)
- Power cord (3m long) (1)
- Link cable (1)
- Monitor cable (remote control) (1)

### 3. SAFETY NOTES

**In order to use this machine safely please read carefully this Manual BEFORE the installation, use or maintenance of the machine.**

This Operator's Manual and others manuals delivered with the machine must be available to the operating and service personnel.

When transporting or reselling the machine, be sure to attach this Manual.

The TOKYOCOP machine has been designed for indoor use only, within residential or commercial areas, and must be used exclusively for the purpose intended.

**GAELCO S.A. bears no responsibility for accidents, injury or damage resulting for unauthorized changes or improper use of the machine.**

**WARNING**

To avoid accidents or damages, it is imperative to follow the notes on Safety resumed bellow, as well as all those included in the following sections:

- SECTION 4. MATERIAL HANDLING
- SECTION 5. UNPACKING, ASSEMBLING & INSTALLATION
- SECTION 9. TECHNICAL SERVICE



### 3.1 GENERAL SAFETY CONSIDERATIONS

---



- Before operating the machine, check that it has been installed correctly and in accordance with this Manual.
- As some parts of the machine move during game play, there are places where the distance between the stationary section and the mobile section changes. Despite the measures implemented to avoid accidents, if the operator feels that a person is in any danger, he should warn that person or stop the machine immediately by using the Emergency Stop button.
- The warning notices (stickers) must be kept in such condition that customers can read them easily.
- Installation, service or routine maintenance should be carried out by qualified personnel.
- Before connecting the machine to the mains supply, verify that it is set for the correct voltage and that the proper fuses are already installed.
- When replacing fuses, use spare fuses of the same type and rating than the originals. The use of other material can cause serious damages on the electronic circuits or even a fire hazard. Check the Parts List to know the exact specifications.
- The machine includes areas of high voltage. Care must be taken at all times to avoid electrical shock whenever inspecting or adjusting the equipment, particularly around the monitor.
- To ensure safe operation, the machine must be grounded with a plug securely connected to Earth.
- Do not turn ON the power switch until the machine has been installed on its dedicated place.

**If there is any error or problem with this machine, operation must be stopped immediately.**

### 3.2 SAFETY PRECAUTIONS CONCERNING LOCATION

---



**Do not place the machine where it might be an obstacle in case on emergency (i.e. close to fire extinguishers or emergency exits).**

**Install and operate the machine in places where appropriate lighting is available, so warning labels can be clearly read by the customers.**

**This machine has been for indoor use only, within residential or commercial spaces. Absolutely do not set up the machine outdoors or under the following conditions:**

- Direct exposure to sunlight, high humidity, water contact, dust, high heat or extreme cold.
- In locations near containers holding liquids or liquid dispensing equipment. In general, precautions should be taken against spilling liquids of any kind whatsoever over the machine
- In a place exposed to vibration. The machine must be installed on a level surface with levellers properly adjusted.
- In locations near ventilating holes. Doing so could cause internal temperature to rise excessively, resulting in equipment failure.
- Near hazardous substances

Furthermore:

- In order to have easy access to the PSU, CPU and control devices, please make sure that the rear and sides of the machine are separated from the wall or other machines by at least 300mm (12")
- Ventilation slots must be not obstructed, and the machine must be positioned so as to leave a distance of at least 100mm (4") from possible obstructions
- Do not run the power cord across passages where pedestrian's feet could get caught on the cord.
- Ensure that the location's power supply is equipped with an Earth Leakage Breaker rated at 30mA.

**GAELCO shall not be held responsible for any damage resulting from the failure to observe these instructions.**

### 3.2.1 SECURING IN PLACE

Ensure that all the leg levellers make firm contact with the surface of the floor. This precaution is crucial for the TOKYOCOP version with motion system, because the machine can move of itself, causing an accident.

After making the adjustment of all legs, secure the height of each one by fastening upward the nut.

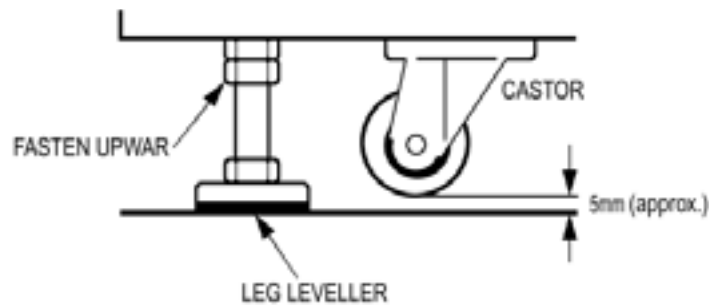

### 3.3 PRECAUTIONS TO BE HEDED WHEN MOVING THE MACHINE



The machine can easily moved by using their castors. When moving the game machine, always retract the levellers to the extreme up position, so the castors can make contact with the floor. Please ensure that the levellers are raised fully when moving the machine, even for short distances. Furthermore:

- Do not use the handlebar or the rear handle to move the platform (rider assembly), unless the levellers are raised fully.
- When moving the machine on slopping or uneven surfaces or across steps, proceed with extreme caution to avoid the risk of being crushed!
- If there are steps or step-like differences in grade, move the machine by separating into each unit. Be sure to catch the bottom part.
- During transportation, pay attention so that de castors do not thread power cords.
- Ensure that there is enough room to get through doors or to avoid any collision with elements hanging from the ceiling. Read section 4 to know the dimensions of the machine.

**The two units of the machine are not equipped with lifting rings. It is therefore absolutely prohibited to lift them with ropes or belts!**

### 3.4 PRECAUTIONS TO BE HEEDED DURING OPERATION

---



Please heed the following indications in order to ensure the safety of the customers when using this game machine. Be sure to read and get a good understanding of each item:

- Before starting the operation, please check if all the level adjusters are in firm contact with the surface of the ground. If they are not, the cabinet can move and cause an accident.
- Do not use the machine as support for other objects.
- Do not put on the machine or near by any kind of receptacle containing chemicals or water.
- Ensure to provide enough space around the machine to avoid the risk of injury or trouble. Insufficient installation space can cause the player to come in contact with spectators or hit them.

In order to avoid injury and accidents, it is not allowed to use the machine to those persons who fall under the following cases:

- Intoxicated persons.
- Persons susceptible to motion sickness.
- Persons who are not in good health, such those having problems of high blood pressure or heart malfunctions.
- Pregnant women
- Persons whose acts do not observe the warning notices.
- Persons who could be unable to support themselves being sitting (disabled people, small children, etc.).

Despite the machine is fitted with protection hoods to avoid access to potentially dangerous places, do not allow customers to put hands, fingers or extraneous matter in any opening of the cabinet.

### 3.5 SAFETY DEVICES CONCERNING THE MOTION SYSTEM

---

The TOKYOCOP / MOTION machine has an EMERGENCY STOP BUTTON placed on top of the coin tower, which can be easily activated by the player or the operator at any time. The game keeps running but the motion stops until the button is unlocked manually by turning it clockwise.

The action of this device reduces the possibility of an accident resulting from sudden sickness or improper use of the machine while it is moving.

---

## 4. MATERIAL HANDLING



This machine should be transported or moved by trained persons. Failing to do so could result in injury or product damage. Please be very careful.

### 4.1 TRANSPORT OF PACKAGED UNITS

---

The packaged machine must be transported in a closed means of transport with sufficient carrying capacity for the gross weight of the machine, which is 205Kg for de monitor cabinet and 325Kg for the platform. The machine, must remain packaged on its pallet and must be suitably secured to the means of transport. It is very important that the lifting forks are pushed right to the back of the wooden pallet, to give optimum stability to the load.

CODE	width	depth	height	crate weight
MONITOR CABINET	1000 mm	800 mm	1935 mm	205 Kg
PLATFORM	1000 mm	1500 mm	1538 mm	325 Kg

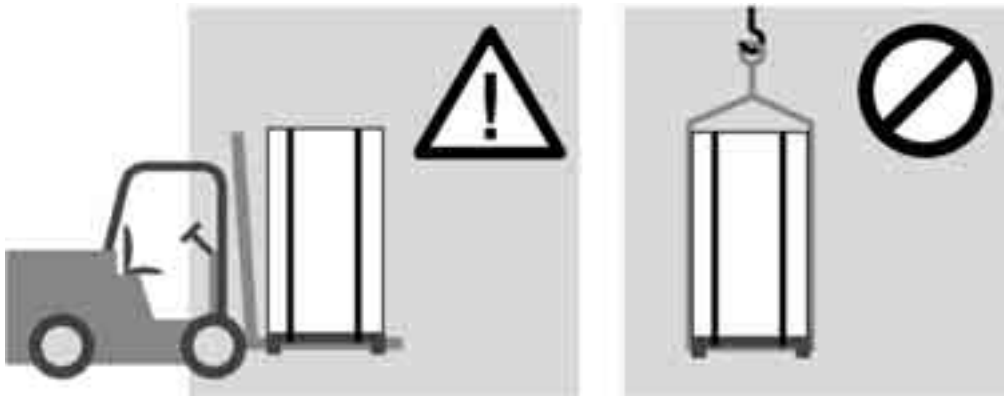

It is not allowed to lift the packed machine with ropes or belts, as the package is not equipped with suitable lifting points for this type of transport.

### 4.2 STORAGE

---

Store the packed machine in sheltered and dry areas. Temperatures allowed: maximum +45°C / minimum -5°C.

### 4.3 RECEPTION

---

The TOKYOCOP packaging should be carefully inspected upon receipt to ensure that the product is delivered in good conditions.

Shipping damage may void warranty. In case of shipping damage, contact your Distributor and the Transportation Carrier immediately. See section 5.1 for further inspection.

## 5. UNPACKING, ASSEMBLING & INSTALLATION

It is best to unpack the machine where it is going to be used or in a place as near as possible to this. Two people are needed to lift the cardboard packaging over the top of each unit.

Once the packaging is removed, the machine looks as shown in the illustration.

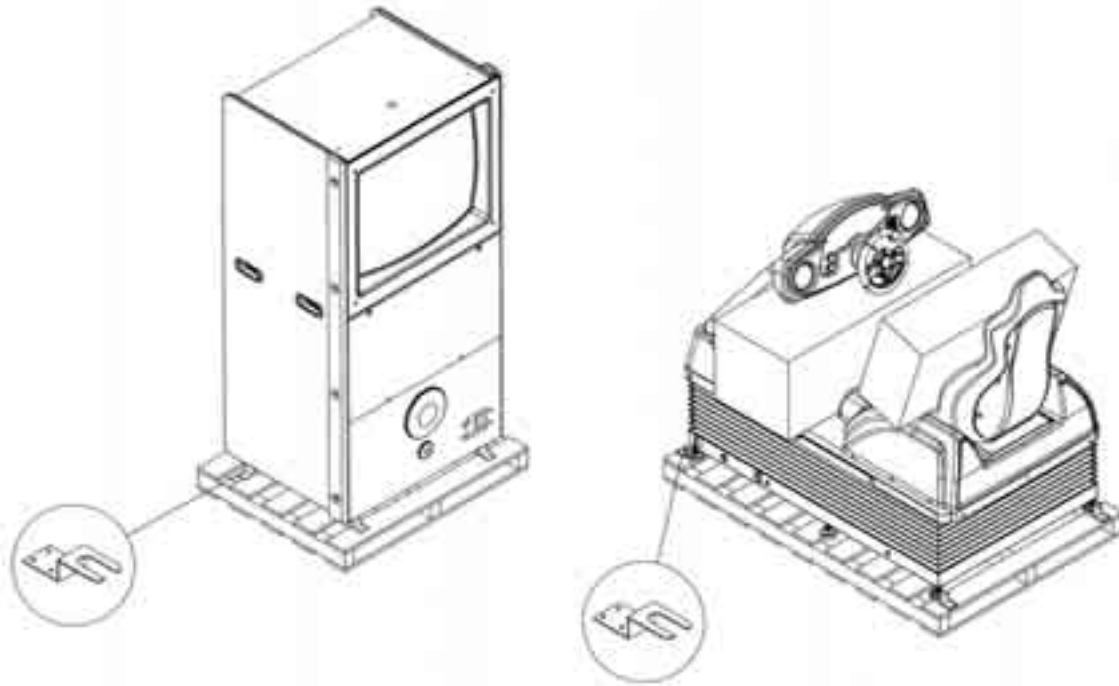

### 5.1 INSPECTION BEFORE ASSEMBLING

---

Normally, GAELCO products are ready to assemble immediately after transporting to the location. Nevertheless, some mishandling may occur during transportation. Check the following points to ensure that the machine has been properly delivered:

- Examine the cabinet exterior for dents, chips, or broken parts
  - Verify that castors and levellers are not damaged
  - Inspect the major assemblies, such as the video display monitor, handlebar and seat. Make sure that they are mounted securely and that all ground wires are firmly connected.
  - Ensure that the power supply voltage and frequency requirements meet those of the location.
  - Ensure that the fuses already installed meet the specified rating and type.
  - Inspect the power cable to ensure that it is not damaged.
  - Verify that the keys delivered with the machine open all doors.
  - Check if all the accessories are included.
-

## 5.2 ASSEMBLING & INSTALLATION

---

To assemble the machine proceed as follows:

1. Take out the boxes containing the accessories.
2. Remove the metal brackets that fix each unit to its pallet.
3. Raise the leg levellers and put the units down on the floor with the help of a ramp. Be very careful to avoid the risk of being crushed!

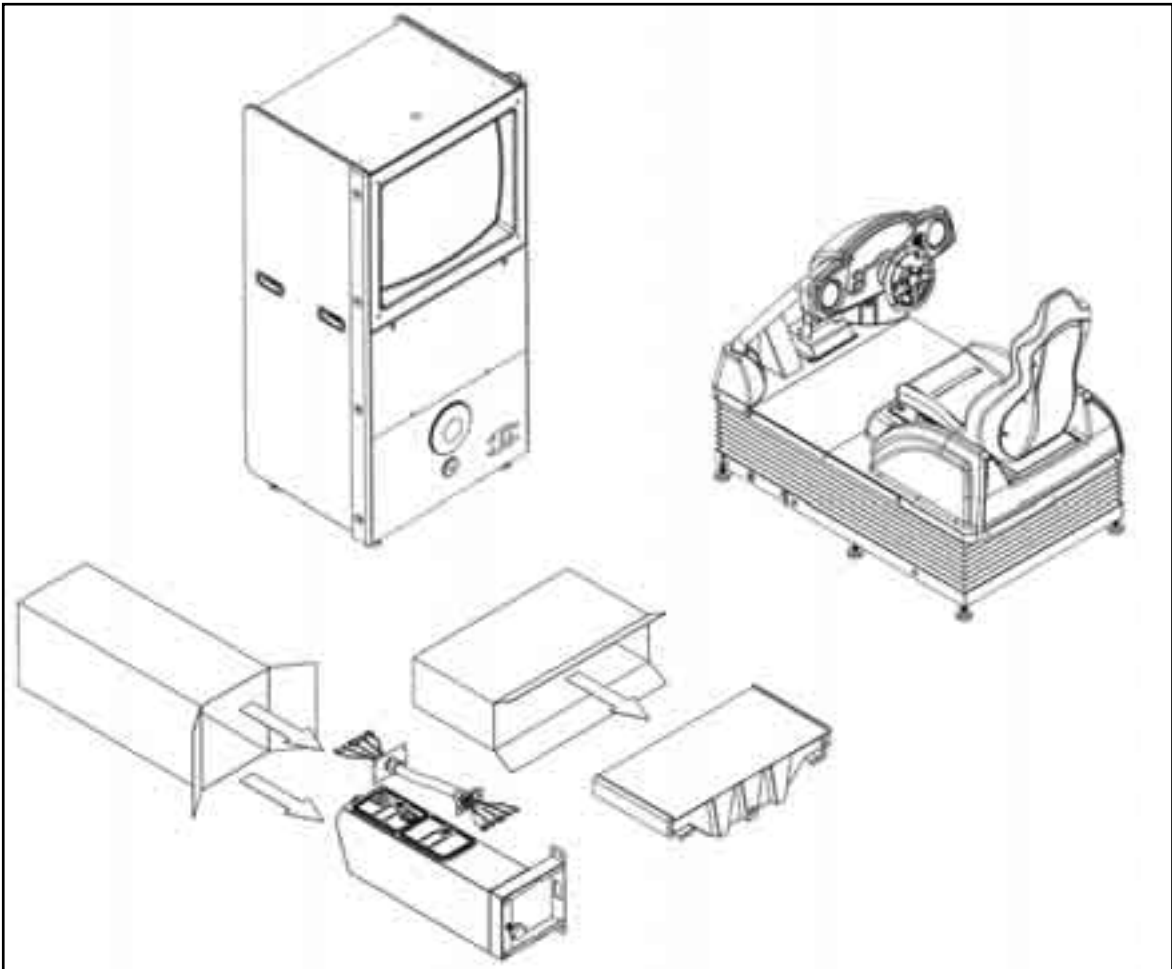

4. Place the monitor cabinet is at its final location and strictly follow the instructions described in section 3.2. Ensure that the cabinet is level, then secure the height of the leg levellers by fastening the adjuster nut upwards.

5. Assemble the billboard on the top of the monitor cabinet, **using a step**. Do not climb on the cabinet! The screws that fix the billboard are already installed on its place. Remove those screws and use them for fixing the billboard. Plug the connector of the fluorescent tube.

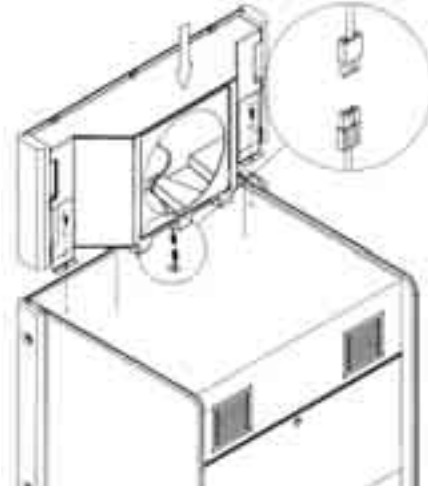

6. Proceed to assemble the two units together. This must be done where the machine is to be used. First of all make sure the monitor cabinet is level. Then follow the steps below:
7. Connect the harness to the platform and fix it. The screws are already mounted on its place. Loose them and screw them again fixing the harness plate.

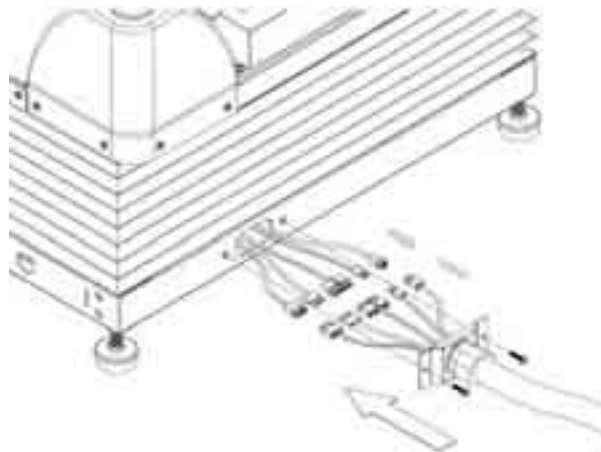



8. Approach the two units so you can connect the other end of the harness to the monitor cabinet. The screws that fix the harness plate are already installed on its place.

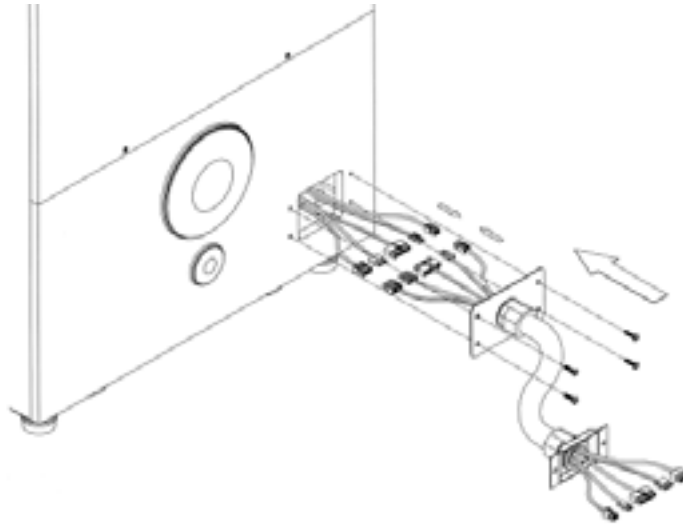

9. The gap between the platform and the monitor cabinet should be about 300mm (12"). When this condition is respected, the harness makes a gentle "S" as shown in the picture.

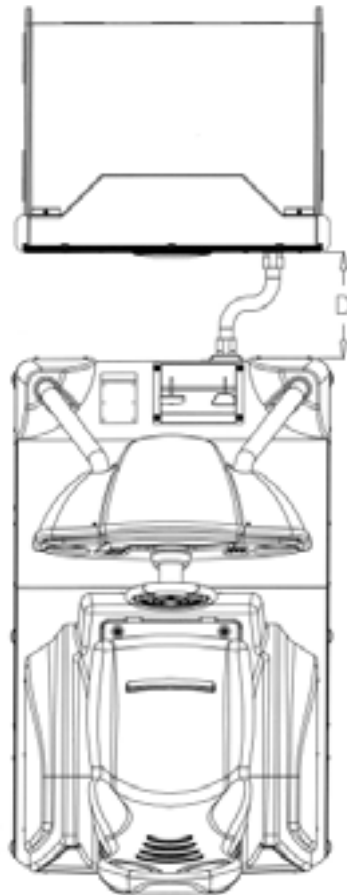

- Level the platform . The levellers of the middle (number 3 in the drawing) should be adjusted the last ones.

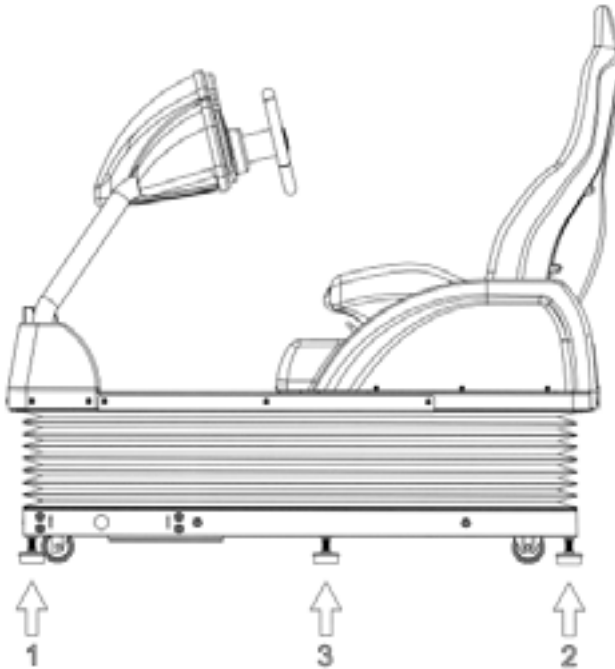

- Carefully adjust all the levellers so that the whole machine rests firm and level on the floor. (See section 3.2.1). Remember that the platform contains a motion system!
- Proceed to assemble the tower to the platform. First of all connect the cable, then fix the tower. The screws for that purpose are already installed on its place. Loose them and screw them again fixing the tower. Adjust the leveler of the tower.

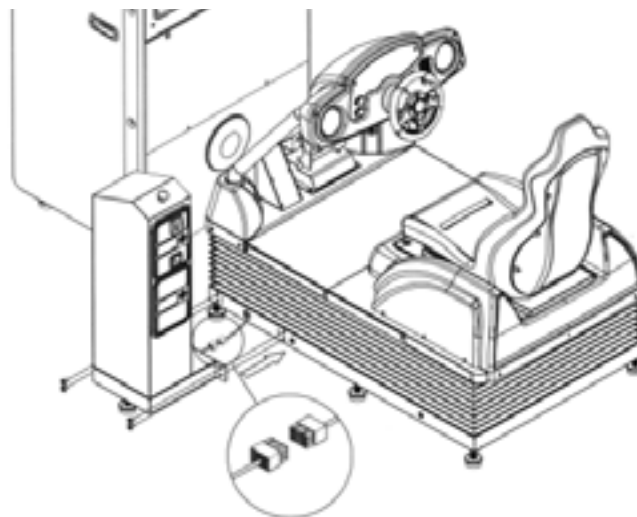

- If the machine has to be moved, though a little bit, retract the leg levellers. **To clean the game machine, wipe with a soft cloth damped with a neutral detergent and wrung out. Using organic solvents like thinner may damage the plastic parts.**

### 5.3 GETTING READY TO START

---



BEFORE SWITCHING ON THE MACHINE, PLEASE CHECK THAT THE INSTALLATION FITS ALL THE REQUIREMENTS DESCRIBED ON CHAPTER 3 (SAFETY NOTES) AND ESPECIALLY THOSE OF SECTION 3.2

The installation of the machine at its final site should be carried out by trained people. Mains power must be always be turned off, and the machine unplugged, before replacing any part or handling connectors. Please check the following points again:

- The area chosen for the machine is well away from heat sources.
- The machine does not obstruct emergency exits.
- The whole machine is level and stable on the floor. The leg levellers are secured in place.
- The power cord can be plugged into a grounded receptacle that provides the specified voltage and frequency.
- The mains supply is equipped with an Earth Leakage Breaker rated at 30mA.

### 5.4 SWITCHING ON THE MACHINE

---

The mains switch is located in the compact filter assembly, which also contains the fuse and the socket for the mains cable. It is found in the back of the monitor cabinet.

To start the machine, push the switch to position "I".

The machine can be switched OFF (position "0") whenever necessary. If a game is in progress on the machine, the credit will be lost.

**To avoid possible damage to the electronic components, wait several seconds before turning the machine on again.**

## 6. PROGRAMMING THE MACHINE AND TEST MODE

An automatic check of the memories is made when the machine is switched on. This coincides with the presentation of the Screen Test. After a few seconds, if no error occurs, it automatically goes on to show the game. The interface is also adjusted dynamically each time that a machine is switched on. Any other adjustment should be made in TEST MODE.

The access to the TEST MODE as for the other controls -monitor, sound, etc.- is made from the CONTROL PANEL, which is situated behind the coin box door. This panel consists of a button to access TEST MODE, a coin counter, a SERVICE button, and a commuter to adjust the VOLUME of the loudspeakers.

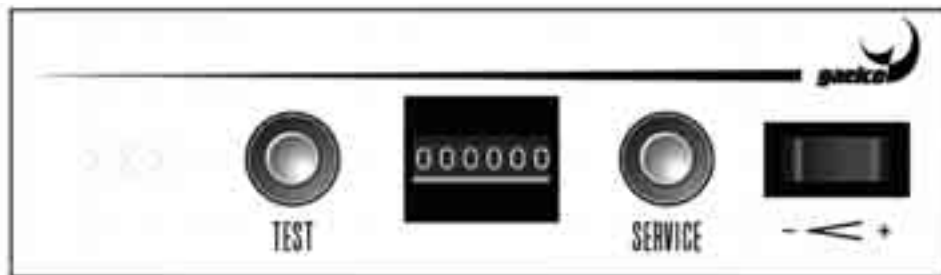

Pressing the TEST button enters TEST MODE, where the game variables, such as level of difficulty, linkage of machines, etc., can be adjusted. A check of the motion system and other controls can also be made. The SERVICE button allows the technician to introduce game credits without moving the coin counter.

The main menu of TEST MODE offers the following options:

- Screen test**
- Controls**
- Motion system**
- Settings**
- Link settings**
- Sound**
- Book-keeping**
  
- Exit and save**
- Exit without saving**

You can choose the option required by pushing the VIEW button (the cursor moves up) or the SIREN button (the cursor moves down). Pushing the START button placed on the steering wheel makes the selection.

To make sure that the changes that have been made are kept permanently, you must not switch off the machine without first leaving TEST MODE with the option **Exit and save**.

## 6.1 SCREEN TEST

---

This screen is the ADJUSTMENT CARD, which should be used to suitably adjust the monitor. It shows you, also, information about the installed software version.

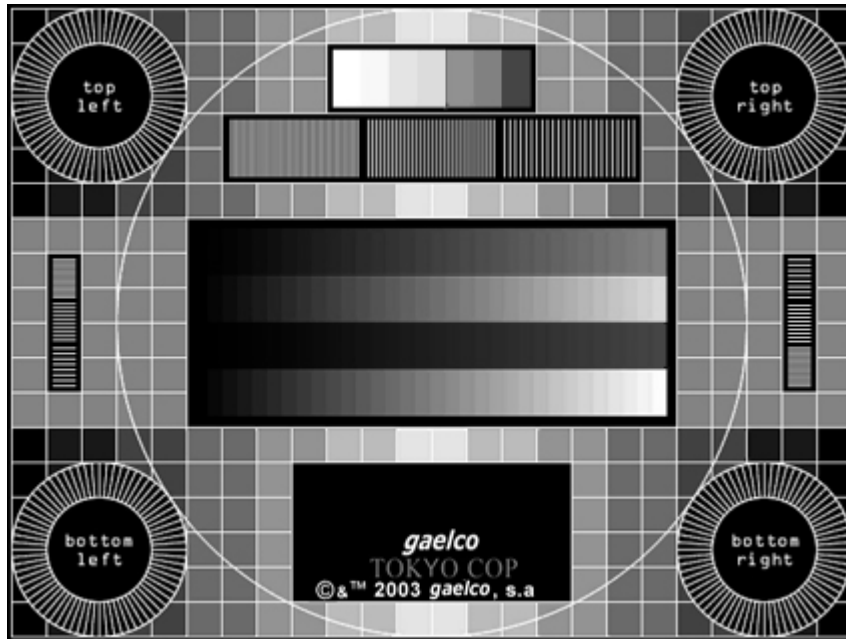

You can return to de Main Menu by pushing the START button placed In the centre of the steering wheel.

## 6.2 CONTROLS TEST

---

This screen enables you to check the correct functioning of all controls of the machine. The device to be tested is selected by pushing the VIEW and SIREN buttons placed on the front panel. To return to the main menu just push both buttons at once.

**Warning!** When checking the EMERGENCY STOP, remember that the message displayed on the screen is ON when the button is released. So, if the message is "OFF", it means that the button is working (motion system disabled). Once pushed, the button will remain mechanically locked until you turn the red knob clockwise.

<b>CONTROLS TEST</b>	
<b>Steering wheel:</b>	
<b>Reading:</b>	<b>128</b>
<b>Force:</b>	<b>-0.46</b>
<b>Horn:</b>	<b>off</b>
<b>Keyboard:</b>	<b>-</b>
<b>Siren:</b>	<b>off</b>
<b>View:</b>	<b>off</b>
<b>Brake pedal:</b>	<b>off</b>
<b>Gas pedal:</b>	<b>0</b>
<b>Coin chute 1:</b>	<b>off</b>
<b>Coin chute 2:</b>	<b>off</b>
<b>Service:</b>	<b>off</b>
<b>Test:</b>	<b>on</b>
<b>Volume:</b>	<b>up</b>
<b>Security</b>	<b>off</b>
<b>Press VIEW button and SIREN to exit</b>	

The Horn button, placed in the centre of the steering wheel, works as START button when the machine is not in game mode.

To return to the main menu, push VIEW and SIREN buttons at once.

### 6.3 MOTION SYSTEM TEST

---

This screen enables you to check some functions related to the motion system.

<b>MOTION SYSTEM</b>	
<b>Left motor</b>	
<b>Start :</b>	<b>1</b>
<b>Turn :</b>	<b>0</b>
<b>Speed :</b>	<b>0</b>
<b>Pot :</b>	<b>38</b>
<b>Right motor</b>	
<b>Start :</b>	<b>1</b>
<b>Turn :</b>	<b>0</b>
<b>Speed :</b>	<b>0</b>
<b>Pot :</b>	<b>60</b>
<b>Security:</b>	<b>OFF</b>
<b>Mode:</b>	<b>ON</b>
<b>Motion test</b>	
<b>Exit</b>	

#### Left Motor / Right Motor

This is an option for maintenance purposes that allows a manual control of each motor, using the keyboard. The keys 7 and \* allows you to control the left motor. The right motor is controlled with the keys 9 and #. The information belonging to "Pot" shows the position of the motor. A reading of 60 should refer to the higher position (shaft crank in vertical position). The rest position of the platform should correspond to a reading of -60.

#### Mode

There are two working modes of the motion system: ON (the motion system is activated) and OFF (the motion is disabled).

#### Security

This option allows you to check the emergency stop button (red knob placed on top of the coin tower). The message displayed on the screen is ON when the button is released. So, if the message is "OFF", it means that the button is working (motion system disabled). Once pushed, the button will remain mechanically locked until you turn the red knob clockwise. It should be noted that the CPU does not detect whether the security circuit is operative but only that emergency stop button is being pressed. Given that the CPU only provides a warning, you have to check that the security circuit is operational by following the relevant troubleshooting sections in this manual.

#### Motion Test

The system moves following a repetitive pattern, allowing you to see if there is anything wrong with it.

#### Return to Main Menu

You leave this screen by choosing the Exit option and then pushing the START button.

---

## 6.4 SETTINGS

---

On this screen you can change the following game parameters:

<b>SETTINGS</b>	
<b>Difficulty:</b>	<b>50</b>
<b>Advertising sound:</b>	<b>YES</b>
<b>Free play:</b>	<b>NO</b>
<b>Credits to start:</b>	<b>1</b>
<b>Credits to continue:</b>	<b>1</b>
<b>Coin /credit conversion:</b>	
<b>1 coins (1)</b>	
<b>1 credits (1)</b>	
<b>1 counter pulses (1)</b>	
<b>1 coins (2)</b>	
<b>1 credits (2)</b>	
<b>1 counter pulses (2)</b>	
<b>Debug mode:</b>	
<b>Save player game:</b>	
<b>Languaje:</b>	<b>ENGLISH</b>
<b>Exit</b>	

As for the previous screens, the parameter is selected with the VIEW and SIREN buttons, then changed by pushing the START button.

### **Difficulty**

This options allows the operator to ajust the level of difficulty of the game. There are three levels: 1, 2 and 3, corresponding to low, normal and hard difficulty.

### **Advertising sound**

By means of this option you can program the machine for sound production (or not) when it is in exhibition mode.

### **Free Play**

This option allows you to play without inserting coins.

### **Credits to start**

Here you can program the number of coins required to start the game.

### **Credits to continue**

When this option is enabled, the player can start a game from the last stage passed on the previous game.

### **Coin / credit coverision**

On this option you can adjust the number of credits (game price) that the machine gives for a defined number of coins. The machine can work with two coin acceptors (USA)

---



**Debug mode**

This option is for programming purposes only and has no utility for the operator.

**Save player game**

This option allows the player to save the game, by means of a personal code introduced with the alphanumeric keypad. The game can be restored later at the same stage as it was when saved.

**Language**

Using this option can change the language of the messages shown on the screen. The languages available are: English and Japanese.

**Exit**

To leave this screen go to the Exit line and push the START button placed in the center of the steering wheel.

**6.5 LINK SETTINGS**

---

This screen shows the status of the machine. This could be: NOT LINKED, MASTER or SLAVE. If it is linked with another machine you have to assign a different status to each one of them: one must be MASTER and the other SLAVE, as indicated on the options.

<b>LINK SETTINGS</b>	
<b>Link mode:</b>	<b>MASTER</b>
<b>Test:</b>	
<b>On line mode:</b>	<b>No</b>
<b>Exit</b>	

Just for playability convenience, it is recommended to assign the MASTER status to the machine placed at the LEFT.

The most common condition is to link two machines directly, with a cable delivered by the manufacturer. In that case you must select "No" for the option **On line mode**. The linking system complies the Ethernet 10/100 specifications.

The **Test** option allows you to know the actual status of the machines. This option has to be selected on both machines and the initial message will be "TESTING". After few seconds the next message will be LINK OK or LINK ERROR. If the machines have different software version, the message will be "THIS VERSION CAN BE UPDATED" for the machine which has the older version, or "THIS VERSION IS THE NEWEST ONE".

**When linked, the two machines must to run the same software version. If not, you must update the PCB which runs the older version.**

To update the software, please proceed as follows:

### UPDATING THE SOFTWARE OF TWO LINKED PCB

1. Switch off both machines.
2. When the machines are in the final location, install the PCB with the latest software in the machine placed at the LEFT side. The PCB to be updated should be installed in the machine placed at the RIGHT side
3. Check that the link cable is properly connected.
4. Switch on both machines.
5. Enter TEST MODE on both machines, using the TEST button of the control panel placed behind the coin acceptor.
6. Select the LINK SETTINGS option on both machines.
7. From the LINK SETTINGS menu, go to the **Link mode** option and select MASTER for the LEFT machine. Select SLAVE for the right machine.
8. Select the **Test** option on both machines.
9. Push the START/horn button of both machines, simultaneously. This button is placed in the center of the steering wheel.
10. If the machines already have the same software version, the message will be LINK OK. In that case go to step 13.
11. If the software must be updated, start the updating process by pressing the VIEW button of the RIGHT machine. It takes a few minutes.
12. The message Update OK appears when the process ends correctly. If not, please repeat the whole procedure from step 1.
13. When the process ends correctly, go back to the main menu and select the **Exit and save** option
14. Switch off the RIGHT machine, that is, the machine which runs with the already updated PCB. Wait few seconds and switch on the machine again.

The message will be LINK ERROR if there is any interconnection problem. This could be due to a cable fault or because both machines have the same status (Master/Master or Slave/Slave).

**The section 8 (ADVANCED OPTIONS) explains the different ways to link the TOKYOCOP machines, and how to connect them to Internet.**

## 6.6 SOUND TEST

---

This screen allows you to check the whole sound system.

<b>SOUND</b>	
<b>Volume:</b>	<b>50%</b>
<b>Bass level:</b>	<b>30%</b>
<b>Left channel test:</b>	<b>OFF</b>
<b>Right channel test:</b>	<b>ON</b>
<b>Woofers test:</b>	<b>OFF</b>
<b>Exit</b>	

As for the previous screens, the selection of the required option is made by means of the VIEW and SIREN buttons. The Volume can be adjusted with the Volume commutator of the Control Panel placed behind the coin door. The Bass level can be adjusted by pushing the START button. Each push increases the level a 10%. The START button is used as well for activate/deactivate the other options.

To leave this screen go to the Exit option and push the START button placed in the center of the steering wheel.

## 6.7 BOOK-KEEPING

---

The data for the activity of the machine are collected on several screens. The first screen shows the following information:

<b>BOOK-KEEPING 1</b>		
<b>Total time</b>	<b>(hh:mm) :</b>	<b>0050:20</b>
<b>Play time</b>	<b>(hh:mm) :</b>	<b>0016:48</b>
<b>Shortest play</b>	<b>(mm:ss) :</b>	<b>01:46</b>
<b>Longest play</b>	<b>(mm:ss) :</b>	<b>11:34</b>
<b>Average play</b>	<b>(mm:ss) :</b>	<b>02:48</b>
<b>Total credits</b>	<b>:</b>	<b>00346</b>
<b>Service games</b>	<b>:</b>	<b>00012</b>
<b>Start games (1P/2P)</b>	<b>:</b>	<b>00310/00285</b>
<b>Continue games (1P/2P)</b>	<b>:</b>	<b>00046/00022</b>
<b>Saved games</b>	<b>:</b>	<b>00010</b>
<b>Next screen</b>		
<b>Reset book-keeping</b>		
<b>Reset player games</b>		
<b>Reset records</b>		
<b>Exit</b>		

Reading from top to bottom:

- Total time the machine is connected in hours and minutes
- Total time the machine is busy in hours and minutes
- Time of the shortest play in minutes and seconds
- Time of the longest play in minutes and seconds
- Time of the average play in minutes and seconds
- Total number of credits
- Credits entered with the SERVICE button
- Credits owed for the coins entered (one or two players)
- Number of plays using the Continue option (one or two players)
- Games saved by players, using the keypad and a personal code
- Go to the next bookkeeping screen
- Reset the information delivered on this screen
- Reset the games saved by the players
- Reset the records
- Exit this page and go to the main menu, by pressing the START button

The second screen shows additional information about the game incidences on each stage.

<b>BOOK-KEEPING 2</b>	
<b>0:00 - 2:00: 0034</b>	<b>4:30 - 5:00: 0016</b>
<b>2:00 - 2:30: 0156</b>	<b>5:00 - 5:30: 0010</b>
<b>2:30 - 3:00: 0017</b>	<b>5:30 - 6:00: 0020</b>
<b>3:00 - 3:30: 0029</b>	<b>6:00 - 7:00: 0021</b>
<b>3.30 - 4.00: 0027</b>	<b>7:00 - 8:00: 0007</b>
<b>4.00 - 4:30: 0014</b>	<b>8.00 - n.nn: 0008</b>
<b>Next screen</b>	
<b>Reset book-keeping</b>	
<b>Exit</b>	

The following book-keeping screens (3rd and successive), are for programming purposes only and have no practical application for the operator.

To leave this screen and return to the Main Menu, select Exit and press the START button.

## 6.8 LEAVING THE TEST MODE

---

The last two options of the main menu allows you to leave the test mode and go back to the play mode.

**Screen test**  
**Controls**  
**Motion system**  
**Settings**  
**Link settings**  
**Sound**  
**Book-keeping**

**Exit and save**  
**Exit without saving**

The selection is made with the VIEW and SIREN buttons. You can leave the Test Mode and save the changes that have been made in the previous screens. In that case you must select the **Exit and save** option. If you want to leave the Test Mode without keeping the changes, you should select the option **Exit without saving** (last line of the menu).

**Warning!** Whatever the changes that have been selected in the previous screens (SETTINGS & MOTION SYSTEM) will be eliminated unless you exit from this final screen using the option **Exit and save**, confirmed with the START button. The program does not request further confirmation, so each option will be validated once you push the START button.

## 7. HOW TO PLAY

### Game's Concept

Neo Koban Police Station is at the heart of Tokyo. Agents Isamu, Kazu, Reika and Junko have to patrol the most conflictive Tokyo's districts: Ginza, Hibiya, Shiujuku y Shibuya. Their mission is to clear the streets of dangerous criminals. Furthermore, their promotion depends on the number of criminals that they capture and arrest, in the least possible time. Or they could also be demoted if they use all their time limit catching the delinquents.

### Game's Features

- The player can choose from 4 agents (2 males and 2 females).
- There are four different districts to look after.
- In each district there are 12 criminals with different danger levels and reward points.
- There are a total of 6 cars available, with different characteristics each, during the game. One car will be available at the beginning of the game and two more will be available as the player progresses and gets promoted. Three additional cars will be able to confiscate from the most dangerous criminals and use them for the chase. Seeing the criminal's profile, the player will decide which car is more appropriate to use for going after them.
- **The criminal chase takes place in an open circuit, so each game could be a new experience for the player.**
- **There's a realistic driving feedback with 2DOF motion system and interactive steering wheel.**
- This is a single player motion machine, which can be linked another one (up to 2 players).
- A **keyboard** has been installed in the cabinet, allowing the player to insert his **pin number**. Every time he inserts the pin in the machine he originally played with, or the one that is linked to (the CPUs can pass information to each other), he will start the game wherever he left off. The machine will also provide him with his position in the ranking, how many criminals he has captured and if any of them have run away from prison.
- **TokyoCop can be connected to Internet.** If that were the case, all the above information would be stored in Gaelco's server and be provided to the player in any TokyoCop machine connected to Internet.

### Starting the game

To start to play it is necessary to put enough coins to cover the price of at least one credit. The number of coins introduced is shown together with the number of coins necessary to obtain one credit. For example, if the programmed number of coins per credit is two, the displayed message will be, step by step: "Credits 0 / 2", "Credits 1 / 2" and "Credits 1". The cost of a credit is programmed from Test Mode (see section 6.4, SETTINGS).

When the necessary coins have been put in, the message "INSERT COIN" changes to "PUSH START BUTTON". By pushing this button the player can choose the game options.

## Game rules

This is a catch game and there's only one golden rule: the player has to intercept the criminal's car as soon as possible. If the player does well, he or she will be promoted and allowed to drive faster cars, pursue more criminals and have fun longer. The CPU learns from the driving style of the player, so the criminal will be more cunning as the game progresses. On the other hand the chase takes place in an open circuit. The final result is an exciting game with many surprising alternatives.

## 8. ADVANCED OPTIONS

### 8.1 LINK MODES

---

TOKYOCOP machines can be linked in three different ways.

1. **Direct link between two machines:** it allows to play shared games between two machines located close enough to install the link cable (2m length) supplied with them.
2. **Single machine connected to Internet:** it allows to send and receive scores and saved games to/from a server supported by Gaelco.
3. **Two linked machines connected to Internet:** it combines features 1 and 2.

The main purpose of Internet connection is to transfer scores and saved games. It is NOT possible to play a shared game through Internet, as this WAN does not support real time transfer of massive data.

TOKYOCOP machines use the same connector for all link modes:

Mode 1. You just need the link cable supplied by Gaelco. This cable is an standard RJ45-RJ45 Ethernet crossed cable, available in any computer shop.

Mode 2. The machine is connected to a modem, router or a LAN HUB with RJ45 connector. The LAN must have access to Internet through a Gateway or Proxy server.

Mode 3. Both machines must be connected to a HUB or SWITCH, which are connected to a modem or router that allows the access to Internet. The HUB (or SWITCH) must support 100Mbps speed, as 10Mbps is not enough to play shared games with linked machines.

### 8.2 ACCESS TO INTERNET

---

The Internet connection allows you to use the facilities provided by the Gaelco server. In that case, the TOKYOCOP machines need to be connected to a LAN (Local Area Network) supporting Internet access. The machines will work inside this LAN as a common computer running an Internet browser, as they use HTTP protocol (port 80). The LAN must use RJ45 connections.

The most common LAN configurations allowing Internet acces are:

---

- **Router:** The machines will connect directly to this router (or to a HUB or SWITCH with access to this router).
- **Proxi server:** In a LAN with Internet access, there is a computer which runs a Proxy software. TOKYOCOP machines, like a common computer, get access to Internet through this Proxy server (or through a HUB or SWITCH with access to this computer). The Proxy configuration must allow HTTP (port 80) access.

All the settings needed to setup the Internet connection are located inside the LINK SETTINGS option of the Test menu. These settings are available when you select **Yes** in the option **On line mode**, as shown here below:

<b>LINK SETTINGS</b>	
<b>Link mode:</b>	<b>MASTER</b>
<b>Test:</b>	
<b>On line mode:</b>	<b>Yes</b>
<b>Base IP:</b>	<b>090.000.000.232</b>
<b>Remote URL/IP</b>	<b>www.gaelco.es/cgi-bin/tokyomaq.pl</b>
<b>Netmask:</b>	<b>255.255.255.000</b>
<b>Gateway/Proxy:</b>	<b>090.000.000.001</b>
<b>DNS:</b>	<b>090.000.000.001</b>
<b>Country:</b>	<b>Spain</b>
<b>Location:</b>	<b>Gaelco</b>
<b>Test</b>	
<b>Exit</b>	

Depending on the way the machine is running, these options must be set as follows:

### 8.2.1 CONNECTION TO INTERNET OF A SINGLE MACHINE

**On line mode:** When this option is set to “Yes”, the machine will work connected to Internet (if it can connect succesfully to the server).

**Base IP:** This is the IP address of the machine inside the LAN. It must be assigned by the LAN administrator.

**Remote URL/IP:** This is the complete URL of the server that will manage the connection of the TOKYOCOP machines. By default it is the Gaelco server located in Spain:

`www.gaelco.es/cgi-bin/tokyomaq.pl`

It also allows raw IP address:

`80.32.94.121/cgi-bin/tokymaq.pl`



**Netmask:** This is the netmask of the LAN, usually 255.255.255.0. It defines when an IP address is located inside or outside the LAN.

**Gateway/proxy:** The IP of the router or proxy server.

**DNS:** The IP address of an available Domain Name Server.

**Country:** The country where the machine is located (i.e. Japan)

**Location:** A more accurate location for the machine (i.e. Paradise Arcade-2)

Once the configuration is set, you can verify the Internet connection by selecting the **Test** option of the **On line mode menu**. If the Internet connection is working properly, the message LINK OK will appear after a few seconds.

## 8.2.2 CONNECTION TO INTERNET OF TWO LINKED MACHINES

When two TOKYOCOP machines are linked, the Base IP must be set to the same IP in both machines.

The effective IP address of the Master machine will be Base IP (i.e. 90.0.0.232). The Slave machine will use Base IP+1 (in this case 90.0.0.233). This means that your network administrator must give you two consecutive IP address.

For the rest, everything remains the same as for a single machine.

### **WARNING**

When two machines are linked and connected to Internet, they need a 100Mbps connection, that is, only 100Mbps HUBs or SWITCHES will work properly. This is NOT necessary for a single machine connected to Internet. In this case a 10Mbps network is enough.



## 9. TECHNICAL SERVICE

### 9.1 PRIOR CONSIDERATIONS

---

Technical service and maintenance must be carried out by qualified staff.

No modifications shall be made to the machine unless these have been approved by the manufacturer in writing. Failure to observe this requirement may cause damage or accidents and will automatically render the guarantee null and void.

If any task needs to be performed which is not described in this manual, please contact the distributor for instructions. The manufacturer declines any liability for damage and injury arising from failure to comply with this requirement

Do not attempt to repair the CPU. It contains sensitive chips that could easily be damaged by even the small internal voltage of a meter. Always return the CPU to your distributor for any repairs.

### 9.2 SAFETY PRECAUTIONS

---



- Before commencing work on the machine, maintenance staff must read this manual carefully and check that all of the safety norms concerning the installation and use of the TOKYOCOP machine. Maintenance staff must advise the operator of any irregularities they observe so that the latter can take the appropriate measures to put matters right.
  - The machine must be disconnected from the power supply before beginning any kind of maintenance work (changing parts, repairs, etc.), except where this is confined to a simple check on whether the machine is working properly. Hold the plug when unplugging the machine - DO NOT PULL ON THE CABLE !
  - Parts of the power supply unit (PSU) and the monitor remain hot or store high voltage even when the machine has been unplugged. Do not touch these parts as electric shock or burns may result.
  - Make sure there is plenty of room for maintenance to be carried out. At least 3 metres should be left free between the machine itself and other objects (e.g. adjacent machines, walls, etc.).
  - When parts need replacing, use only those approved by Gaelco S.A. and which meet the relevant specifications.
-

### 9.3 MOTION SYSTEM - BLOCK DIAGRAM

For a better understanding of the motion system, please refer to the diagram below.

The CPU Board (TOK-357) provides four analogic signals (0-3V) to the Power Board (TOK-358). Two of them are the inputs of the DC driver, which controls the steering motor with a +/-24V output. The remaining two signals have to be modified in order to supply the 0-10V input required by the AC drivers for the speed control.

The AC drivers have three more inputs: ON/OFF (go/stop), TURN (direction of the turn) and RD (ready status). Those inputs receive a digital signal controlled by the CPU Board. The high level (24V) is generated by the left AC driver drawn in this block diagram (Commander SE / TOK-392). The right driver is not shown.

The position signals processed by the CPU come from potentiometers coupled to the shafts of the motors. If the Emergency Stop button is activated, the RD input falls down to 0V and both AC drivers are disabled.

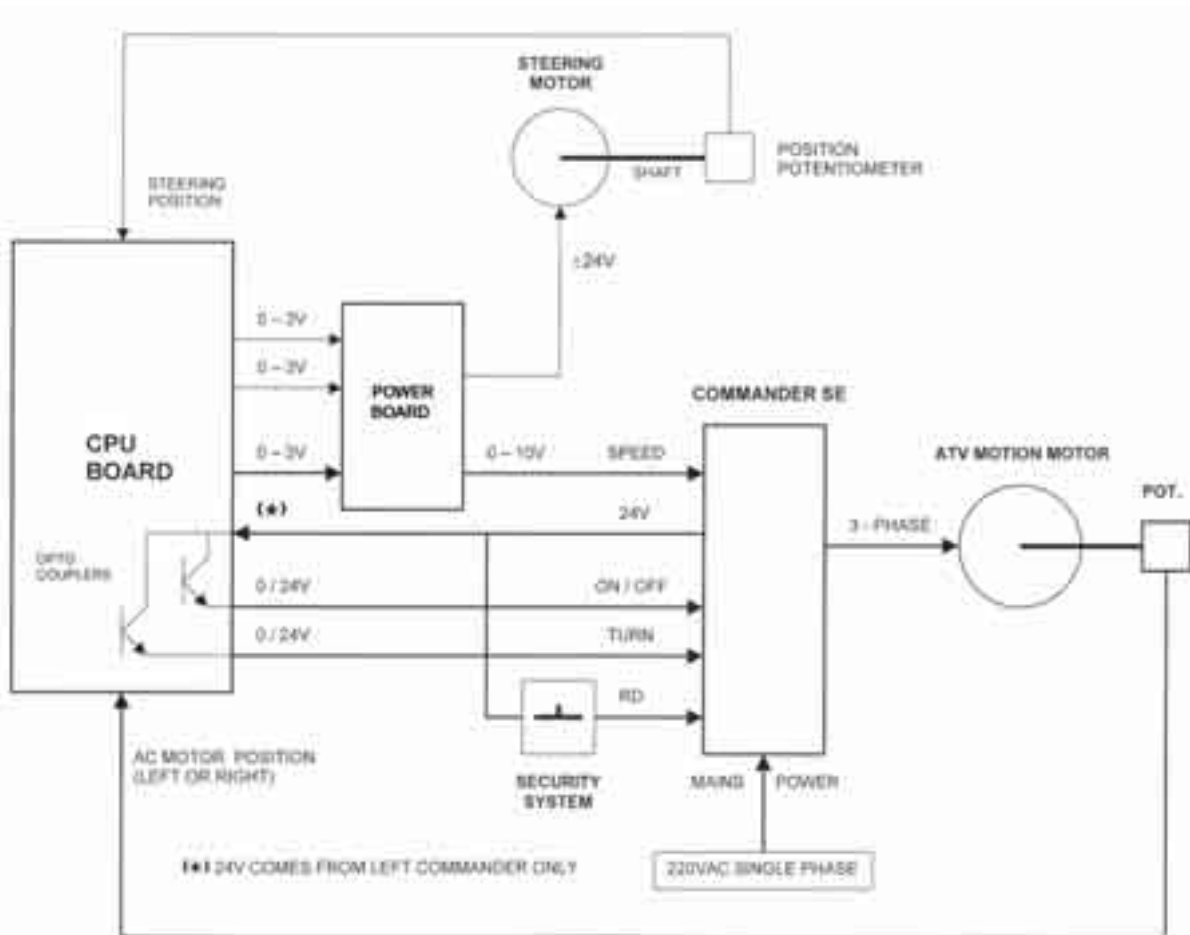

## 9.4 EMERGENCY STOP

---

The motion system includes an emergency stop which is operated by a red knob on top of the coin tower. The emergency circuit-breaker is connected in series so that it will bring the car to a standstill (see the block diagram of section 9.3). Should the movement system not work, the cause may lie in: either of the stop switch; in the cables; or on the CPU board. Actually, the emergency stop button activates two circuits: one runs through the CPU and only serves to give a screen warning that the button has been pressed. The other circuit is the real emergency stop, which does not run through the CPU but acts directly on the frequency converters governing the AC motors.

The following steps must be taken before finding the fault:

1. Open the front door of the monitor cabinet.
2. Remove the Faraday cage which covers the motor drivers (see the exploding 10.8). This reveals the LED displays which provide information on the state of each driver.
3. To check the emergency stop circuit, go to the MOTION SYSTEM screen in Test Mode and select the line "Security": if the red knob is in the rest position (circuit closed, movement possible), the message will read ON. When the red knob is pressed, the message will change to OFF (circuit open, motors stopped). When the knob is turned clockwise, the movement system is ready to operate. The message turns back to ON (movement system ready).

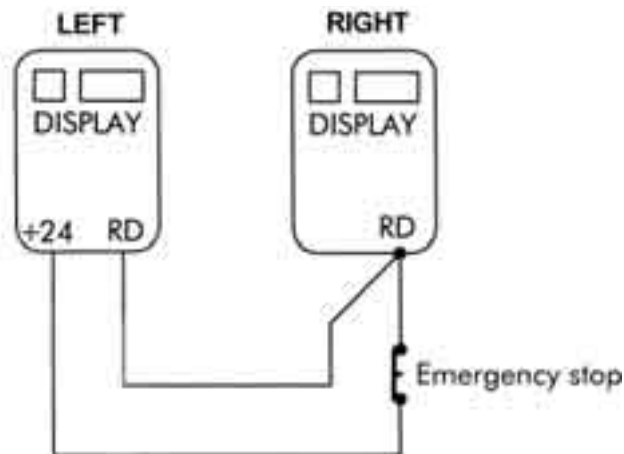

However: the previous check only covers the signal processed by the CPU but the problem could lie in the actual security circuit which goes directly to the drivers. It should be noted that the CPU does not detect whether the security circuit is operative but only that the emergency stop button is being pressed. To check whether this is the case, select the Motion Test from the MOTION SYSTEM screen while in Test Mode. Refer to the circuit diagram in following the steps below:

Under normal conditions, when the button is in the rest position (i.e. not pressed), the message "rd" will appear in the left-hand window of both drivers. However, if the message is "ih", this indicates that the circuit remains open for some reason (e.g. bad connection, damaged cable, faulty button, etc.). The stop message will appear on the monitor screen, consisting of an image of the stop knob and an acoustic warning.

The most likely fault would be a short-circuit if the message of the drivers is neither "rd" nor "ih" and there is no stop message on the monitor.

---

## 9.5 POSITION POTENTIOMETERS

---

If the movement system is not working properly, the position potentiometers (TOK-305) should be checked and changed if necessary. The following points need to be borne in mind in this connection:



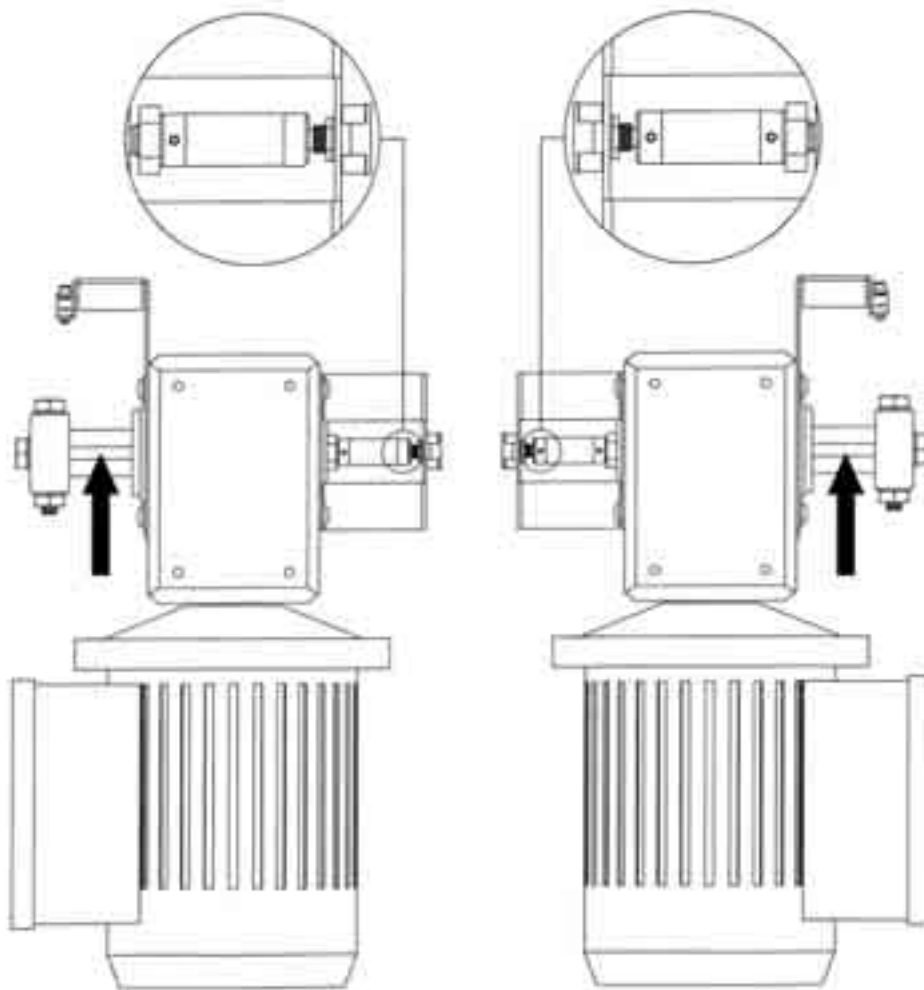

1. In Test Mode, go to the MOTION SYSTEM screen.
2. When the shaft lever is completely upright, the woodruff key will also be in the upright position. Reach this position using the Left motor / Right motor options (see section 6.3), then read the the "Pot" information for each motor. It should be 60 for both motors, approximately.
3. Viewing the motors from above, when the shafts are in the position indicated, check that the grub screw of the elastic couplings are in the same position as shown in the drawing. The left elastic coupling has the grub screws mounted in opposite, while the right coupling has the grub screws aligned.



## 9.6 CHECKING THE COMMANDER SE PARAMETERS

If the motion system does not work properly, you can check the parameter values, which should match the ones shown on the list below.

Starting position: Machine connected, movement system off.

STEP	ACTION and DISPLAY
0	THE COMMANDER IS IN STATUS MODE
1	PRESS  TO ENTER IN VIEW MODE (LEFT DISPLAY FLASHES THE LAST POSITION READ)
2	PRESS  TO SELECT THE PARAMETER NUMBER AND CHECK ITS VALUE (LEFT DISPLAY FLASHING). REPEAT THE OPERATION AS MANY TIMES AS NECESSARY 
3	HOLD  DURING 2 SECONDS TO RETURN TO STATUS MODE

Nr.	Value
1	0.0
2	50
3	0.5
4	0.5
5	A1.PR
6	4.30
7	1500
8	230
9	0.85
10	L2
11	0.0
12	0.0
13	0.0
14	0.0
15	1.5
16	4-.20
17	OFF
18	--
19	--
20	--
21	--
22	A

Nr.	Value
23	SP
24	1.00
25	0
26	ON
27	0
28	NO
29	NO
30	1
31	1
32	OFF
33	0
34	ON
35	2
36	Fr
37	6
38	0
39	50.0
40	Auto
41	AnSi
42	4.8
43	1.1
44	--

Frequency converter model: COMMANDER SE

If the programming is wrong, contact the manufacturer.

The error codes can be checked by consulting the short manual for the Commander, supplied with the machine.

## 9.7 TROUBLESHOOTING PROCEDURES

---

### 1) PROBLEM: The machine does not start when the mains switch is thrown.

#### CHECKS

- Check the mains cable and its connections.
  - Check the fuses. Check the specifications are met. Check whether the fuses have blown and that they have the correct current rating. The fault may have been caused by an overload current.
  - Check the CPU connections
  - Check there is +5V DC in the power supply.
- 

### 2) PROBLEM: There is something wrong with the screen colours and/or image.

#### CHECKS

- Enter in Test Mode and adjust the monitor settings with the help of the screen test (see Section 6.1)
- 

### 3) PROBLEM: The game starts but the platform fails to move.

#### CHECKS

- Check the emergency stop button is not pressed.
  - Check that the connections between the monitor casing and the game platform are not loose and that the cables are undamaged.
  - Check that the frequency converters work properly (i.e. no error message)
  - Check the Power board (TOK-358): If the fuses have blown, it is likely that the power transistors have short-circuited.
- 

### 4) PROBLEM: The game platform moves but not in synchronism with the image on the monitor.

#### CHECKS

- Enter the MOTION SYSTEM screen in Test Mode and check that the platform is at its highest point when taking the reading position of both motors. The reading should be 60. If this is not the case or the platform leans to one side, check the position potentiometer following the procedure described in Section 9.5.
  - Check that the centering screws (TOK-829) are properly tightened on their respective shafts.
  - Check that the elastics couplings (TOK-819) are properly connected.
- 

### 5) PROBLEM: The platform moves very slowly the whole time.

#### CHECKS

- Check the position potentiometers are working properly and that none of the cables have broken.
-





## 10. PARTS LIST - GENERAL INDEX

**PLASTIC PARTS**

CODE	DESCRIPTION	SECTION	POSITION
TOK-434	GRAB HANDLE, monitor cabinet	10.1	5
TOK-510	PLASTIC FRAME, monitor	10.1	7
TOK-801	SEAT, mobile platform	10.15	1
TOK-802	BACK COVER, seat	10.15	6
TOK-803	SEAT BASE COVER, mobile platform	10.15	5
TOK-805	FRONT COVER, dashboard	10.12	1
TOK-806	BACK COVER, dashboard	10.11	3
TOK-807	PLASTIC COVER, tubes of mobile platform	10.16	6
TOK-808	SAFETY COVER, tubes of mobile platform	10.11	8
TOK-865	LOUDSPEAKER COVER, dashboard	10.11	5
TOK-882	KEYPAD FRAME, dashboard	10.11	7

**DESIGN PARTS & ACCESOIRES**

TOK-363	FAN, monitor cabinet	10.8	5
TOK-365	FAN GRILL, monitor cabinet	10.8	6
TOK-367	VENTILATION GRILL, monitor cabinet	10.5	1
TOK-372	LEVELER, monitor cabinet	10.9	4
TOK-375	8 " GRILL, subwoofer - monitor cabinet	10.2	1
TOK-376	2 " GRILL, monitor cabinet	10.2	2
TOK-432	CASTOR, monitor cabinet	10.9	1
TOK-433	SWIVELING CASTOR, monitor cabinet	10.9	2
TOK-434	GRAB HANDLE, monitor cabinet	10.1	5
TOK-502	LEFT STICKER, monitor cabinet	10.1	3
TOK-503	RIGHT STICKER, monitor cabinet	10.1	4
TOK-810	PROTECTION FOLDING HOOD, platform	10.16	4
TOK-811	LEFT STICKER, seat base cover	10.15	20
TOK-812	RIGHT STICKER, seat base cover	10.15	19
TOK-813	STICKER, seat back cover	10.15	7
TOK-814	REAR STICKER, seat base cover	10.15	21
TOK-817	EMERGENCY STOP BUTTON, coin tower	10.19	5
TOK-819L	ELASTIC COUPLING, left motor	10.18	7
TOK-819R	ELASTIC COUPLING, right motor	10.18	7
TOK-835	DERIVATION TERMINAL BLOCK, monitor cabinet	10.8	8
TOK-851	STEERING WHEEL, dashboard	10.12	5
TOK-854	PUSH BUTTON, steering wheel	10.12	6
TOK-861	LEVELER, platform	10.17	8
TOK-861	LEVELER, platform	10.19	3
TOK-862	CASTOR, platform	10.17	7
TOK-863	SWIVELING CASTOR, platform	10.17	6
TOK-880	PUSH BUTTON, dashboard	10.12	3

**WOODEN PARTS**

TOK-110	MOUNTING BASE	10.7	5
TOK-104	CABINET FRONT DOOR	10.6	2
TOK-105	CABINET REAR DOOR	10.5	3
TOK-121	LEFT SIDE COVER, billboard	10.4	1
TOK-122	RIGHT SIDE COVER, billboard	10.4	2
TOK-131	LEFT SIDE COVER, cabinet	10.1	1
TOK-132	RIGHT SIDE COVER, cabinet	10.1	2

**ELECTRIC & ELECTRONIC PARTS**

CODE	DESCRIPTION	SECTION	POSITION
TOK-350	MONITOR	10.6	1
TOK-355	PSU	10.7	2
TOK-357	CPU	10.7	1
TOK-358	POWER PCB	10.7	4
TOK-362	8" SUBWOOFER	10.2	3
TOK-363	FAN	10.7	5
TOK-364	MAINS SWITCH AND FUSE HOLDER	10.5	2
TOK-370	TOROIDAL TRANSFORMER	10.7	3
TOK-372	INDUCTANCE	10.8	4
TOK-390	SERIAL FILTER	10.8	3
TOK-391	MONOPHASIC FILTER	10.8	2
TOK-392	FREQUENCY INVERTER	10.8	1
TOK-820	GEARED MOTOR right	10.17	3
TOK-821	GEARED MOTOR left	10.17	4
TOK-833	4" LOUDSPEAKER	10.11	4
TOK-855	POTENTIOMETER	10.18	9
TOK-881	KEYPAD	10.11	6

**METALIC PARTS**

TOK-224	METAL FRAME, monitor	10.1	8
TOK-225	ARADAY BOX	10.8	7
TOK-230	FIXING PLATE, union harness	10.3	2
TOK-234	BRACKET, monitor	10.6	7
TOK-235	BRACKET leveler	10.9	3
TOK-299	TEST PANEL, coin tower	10.19	6
TOK-826	HEXAGONAL ROD, motor transmission	10.18	3
TOK-827	SHAFT CRANK, motor transmission	10.18	2
TOK-834	COIN TOWER	10.19	1
TOK-835	TOWER BASE	10.19	2
TOK-836	METALIC COVER, motors	10.16	3
TOK-837	PROTECTION PLATE, sear slides	10.15	2
TOK-838	SUPPORTING PLATE, seat	10.15	4
TOK-840	FIXING PLATE, union harness	10.3	5
TOK-841N	SUPPORTING PLATE, motor	10.18	5
TOK-846	BRACKET, protection folding hood	10.16	5
TOK-848	BRACKET, potenciometer	10.18	8
TOK-853	COUPLING CYLINDER, steering wheel	10.12	4
TOK-885	HANDLE, seat slides	10.15	3
TOK-886	SEAT SLIDE right	10.15	18
TOK-887	SEAT SLIDE left	10.15	17

**ASSEMBLIES**

TOK-515	BILLBOARD ASSEMBLY	10.1	6
--	STEERING ASSEMBLY	10.13	--
--	UNION HARNESS ASEEMBLY	10.3	--
--	PEDALS ASSEMBLY	10.14	--
TOK-517	FLUORESCENT ASSEMBLY	10.4	1

**STRUCTURAL PARTS**

TOK-831N	PLATFORM BASE	10.17	1
TOK-832	MOBILE PLATFORM	10.16	1
TOK-839S	CARDAN ASSEMBLY	10.17	2

**10.1 MONITOR CABINET – ACCESSORIES**

	CODE	DESCRIPTION
1	TOK-131	SIDE COVER - LEFT
2	TOK-132	SIDE COVER - RIGHT
3	TOK-502	STICKER - LEFT
4	TOK-503	STICKER - RIGHT
5	TOK-434	PLASTIC GRAB HANDLE
6	TOK-515	BILLBOARD ASSEMBLY
7	TOK-510	PLASTIC FRAME - monitor
8	TOK-224	METAL FRAME - monitor
9	--	SCREW UM1001 M6X20 Z
10	--	SCREW UM1001 M8X40

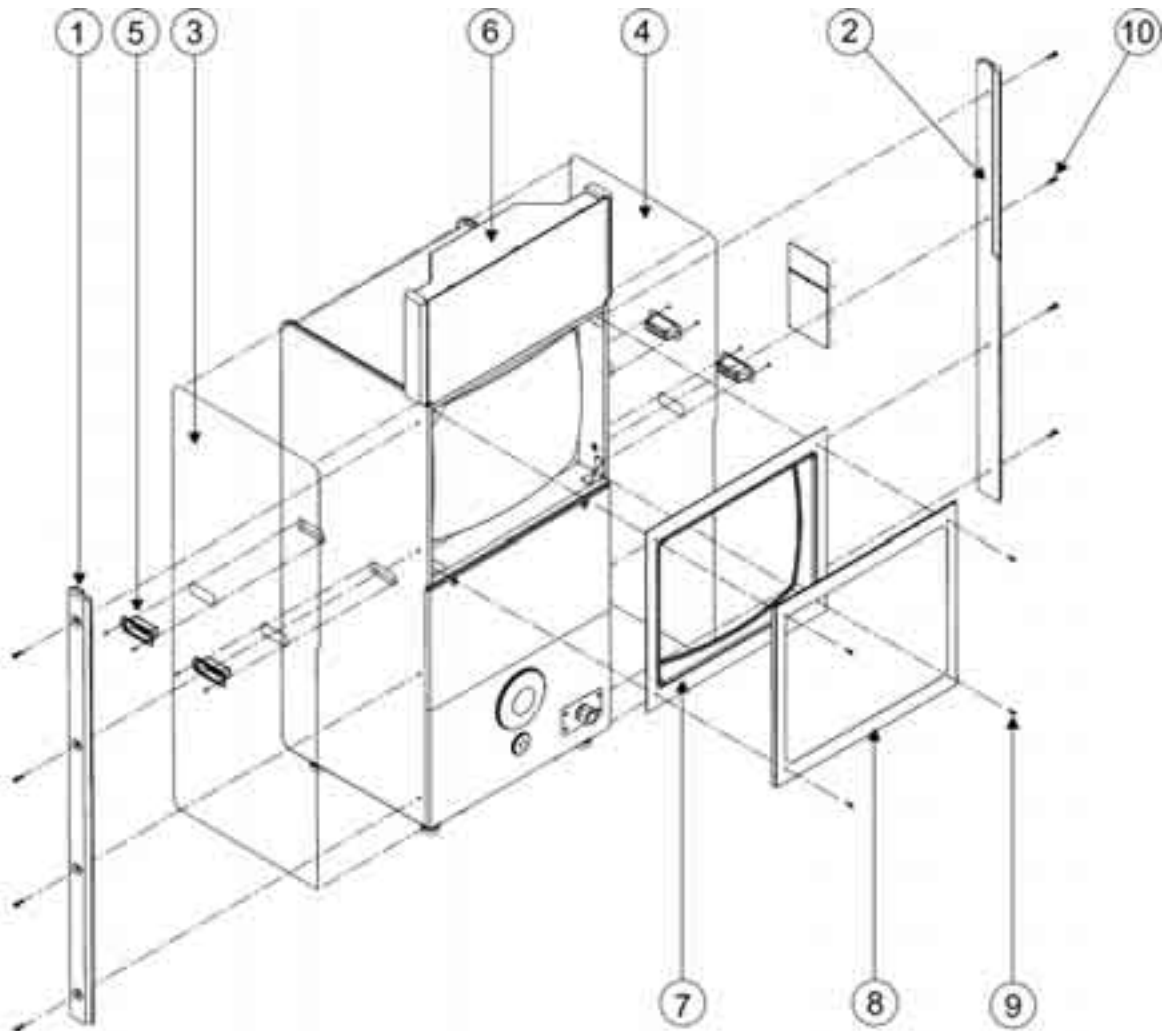

**10.2 MONITOR CABINET – SUBWOOFER PARTS**

	CODE	DESCRIPTION
1	TOK-375	8" GRILL (subwoofer)
2	TOK-376	2" GRILL
3	TOK-362	8" SUBWOOFER 100W/4Ω
4	--	UNION HARNESS (see section 1.3)
5	--	SCREW UM1001 M6X30 BLACK

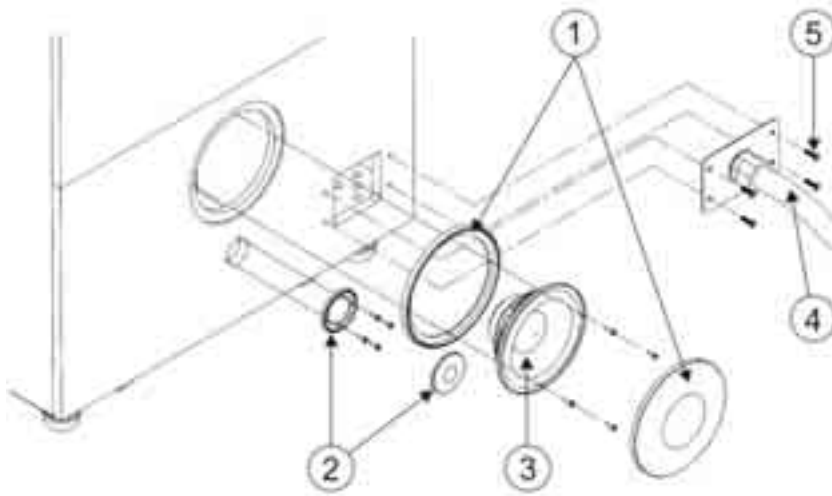

**10.3 UNION HARNESS ASSEMBLY**

	CODE	DESCRIPTION
1	TOK-441	NUT, conduit gland
2	TOK-230	FIXING PLATE - CABINET SIDE
3	TOK-442	CONDUIT GLAND - SEM STRAIGHT
4	TOK-443	PROTECTION TUBE, corrugated
5	TOK-840	FIXING PLATE - PLATFORM SIDE
6	-	UNION HARNESS (see note)

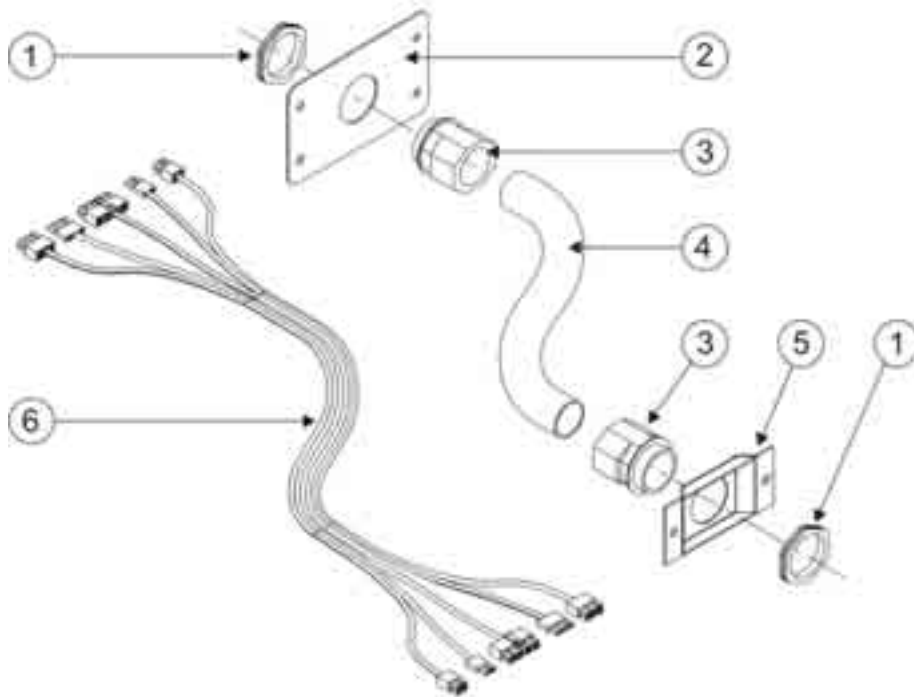

The union harness is includes the following parts:

- TOK-337 (SIGNALS HARNESS)
- TOK-338 (LEFT MOTOR HARNESS)
- TOK-339 (RIGHT MOTOR HARNESS)
- TOK-340 (GROUND HARNESS)

**10.4 MONITOR CABINET – BILLBOARD ASSEMBLY**

---

	CODE	DESCRIPTION
1	TOK-517	FLUORESCENT ASSEMBLY
2	TOK-121	SIDE COVER - LEFT
3	TOK-122	SIDE COVER - RIGHT
4	--	SCREW DIN7505 B4X10
5	--	SCREW UM1001 M6X30 BLACK

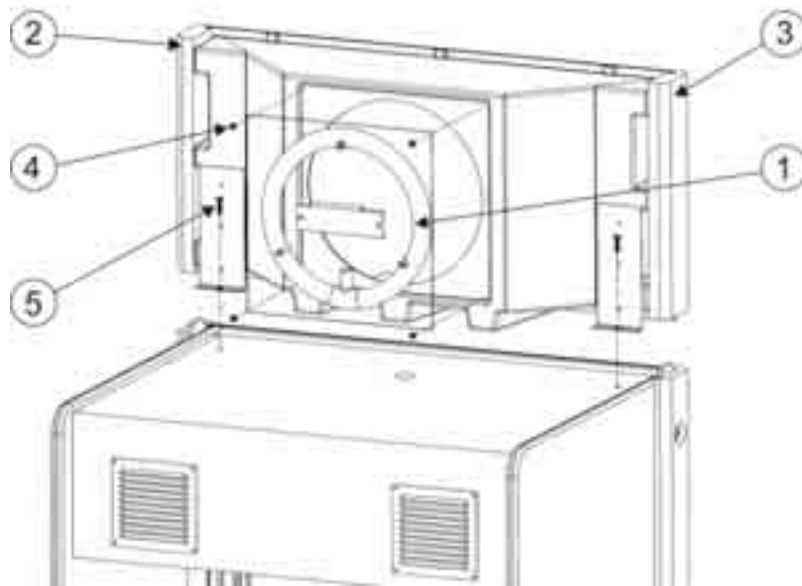

**10.5 MONITOR CABINET – REAR ACCESORIES**

---

	CODE	DESCRIPTION
1	TOK-367	VENTILATION GRILL 15X15
2	TOK-364	MAINS SWITCH & FUSE HOLDER (2X10A)
3	TOK-105	REAR DOOR - MONITOR

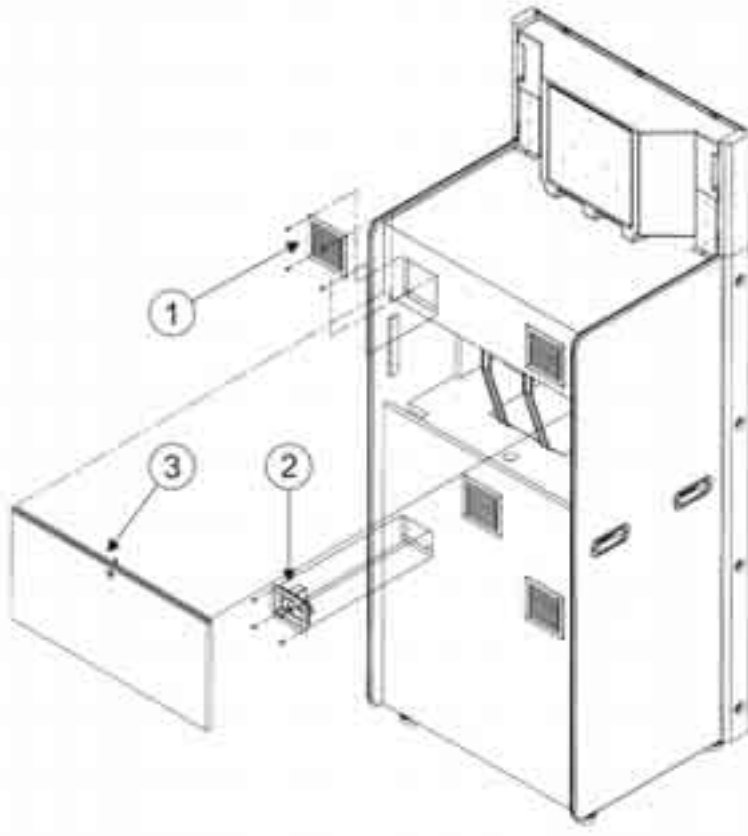



**10.6 MONITOR CABINET – MONITOR ASSEMBLY AND FRONT DOOR**

	<b>CODE</b>	<b>DESCRIPTION</b>
1	TOK-350	MONITOR Polb2 - 34", STAR PH - CODE 02197790
2	TOK-104	FRONT DOOR
3	--	SCREW DIN 603 M8X45
4	--	WASHER DIN125 M8
5	--	NUT DIN938 M8
6	--	NUT985 M8
7	TOK-234	BRACKET, monitor

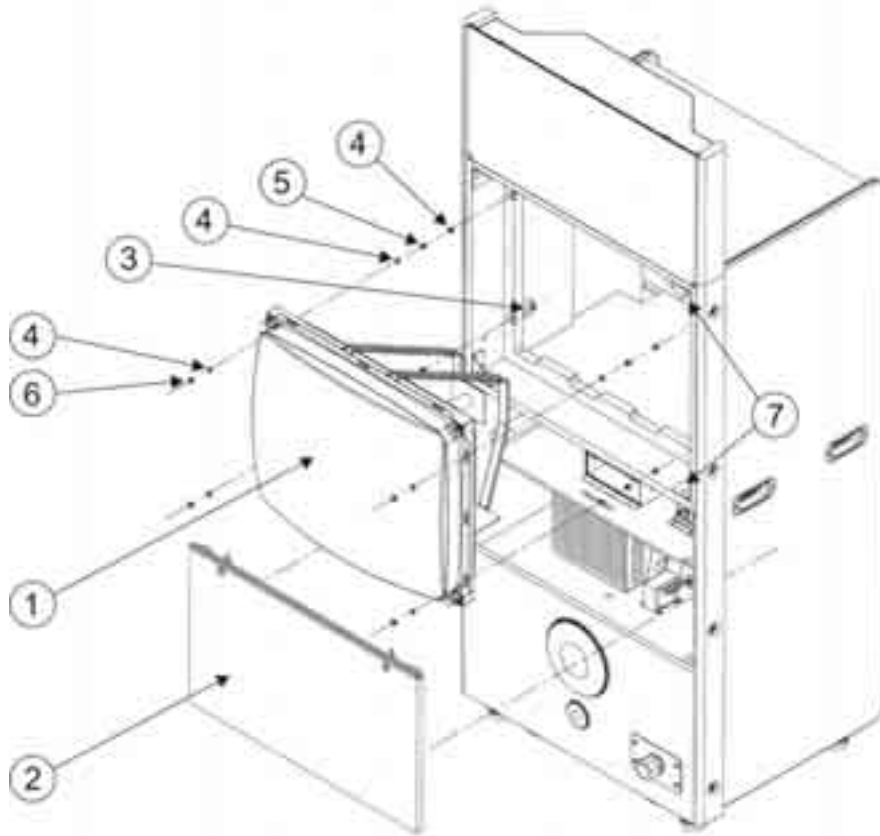

**10.7 MONITOR CABINET – ELECTRONIC PARTS 1**

---

	CODE	DESCRIPTION
1	TOK-357	CPU - TOKYOCOP
2	TOK-355	PSU - PSATX10300
3	TOK-370	TOROIDAL TRANSFORMER 220/18-0-18 160VA - CROVISA 218316
4	TOK-358	POWER PCB - DC MOTOR DRIVER & SIGNAL ADAPTER
5	TOK-110	MOUNTING BASE (WOOD)

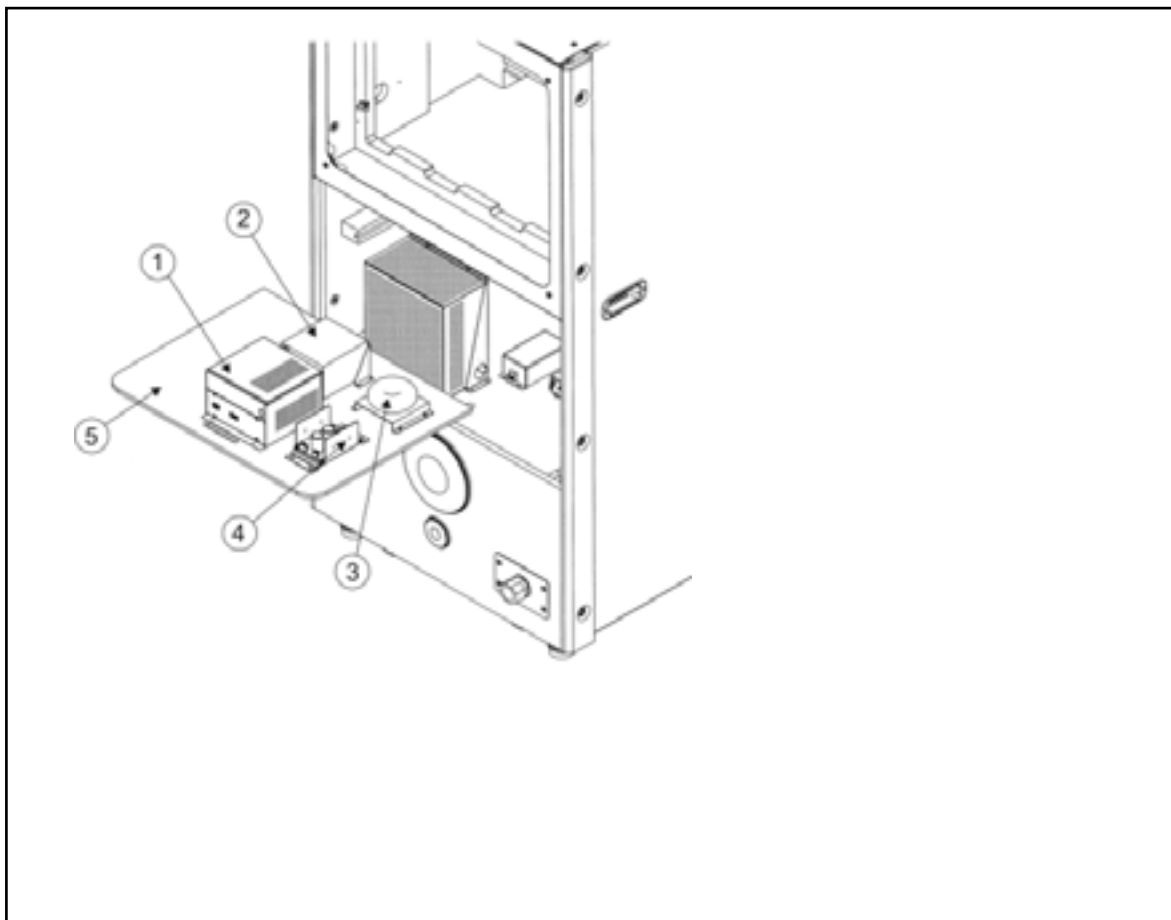

**10.8 MONITOR CABINET – ELECTRONIC PARTS 2**

	CODE	DESCRIPTION
1	TOK-392	FREQUENCY CONVERTER SE11200075
2	TOK-391	MONOPHASIC FILTER 25A CODE 11018
3	TOK-390	SERIAL FILTER 800/6A
4	TOK-372	INDUCTANCE 25mH/6,3A
5	TOK-363	FAN 120X120X38
6	TOK-365	FAN GRILL (metallic)
7	TOK-225	FARADAY BOX
8	TOK-385	DERIVATION TERMINAL BLOCK

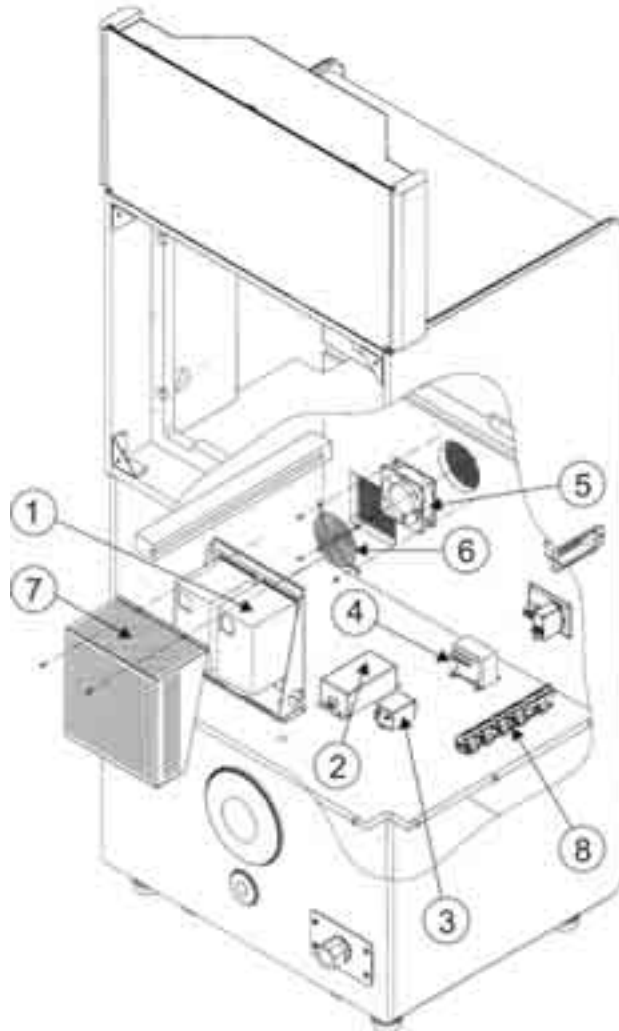

**10.9 MONITOR CABINET – BOTTOM PARTS**

	CODE	DESCRIPTION
1	TOK-432	CASTOR Ø80
2	TOK-433	SWIVELING CASTOR Ø80
3	TOK-235	BRACKET, leg leveller
4	TOK-372	LEG LEVELLER
5	--	SCREW DIN603 M8X45, castor
6	--	NUT DIN985 M8
7	--	SCREW DIN603 M6X70, leg leveller
8	--	NUT DIN985 M6, leg leveller
9	--	SPRING WASHER DIN127 M6
10	--	SPRING WASHER DIN127 M8

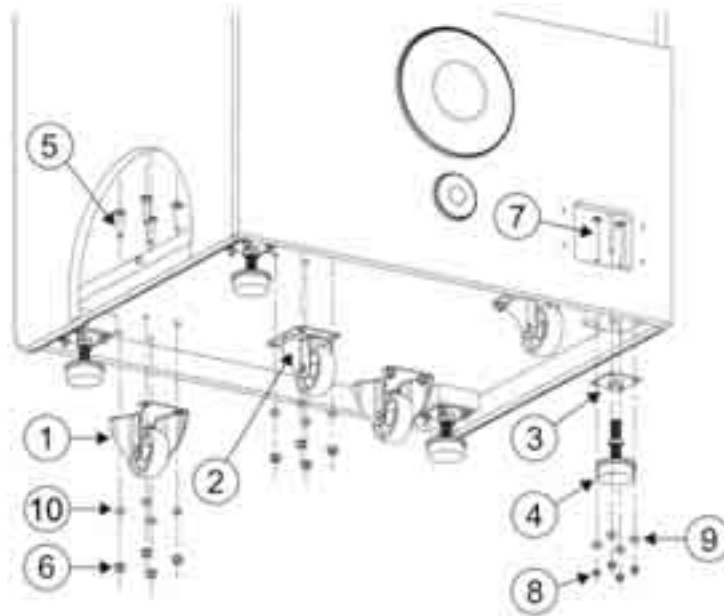

**10.10 PLATFORM – MAIN ASSEMBLIES**

	CODE	DESCRIPTION
1	--	DASHBOARD ASSEMBLY
2	--	SEAT ASSEMBLY
3	--	MOBILE PLATFORM ASSEMBLY
4	--	PROTECTION FOLDING HOOD
5	--	BASE ASSEMBLY
6	--	COIN TOWER ASSEMBLY

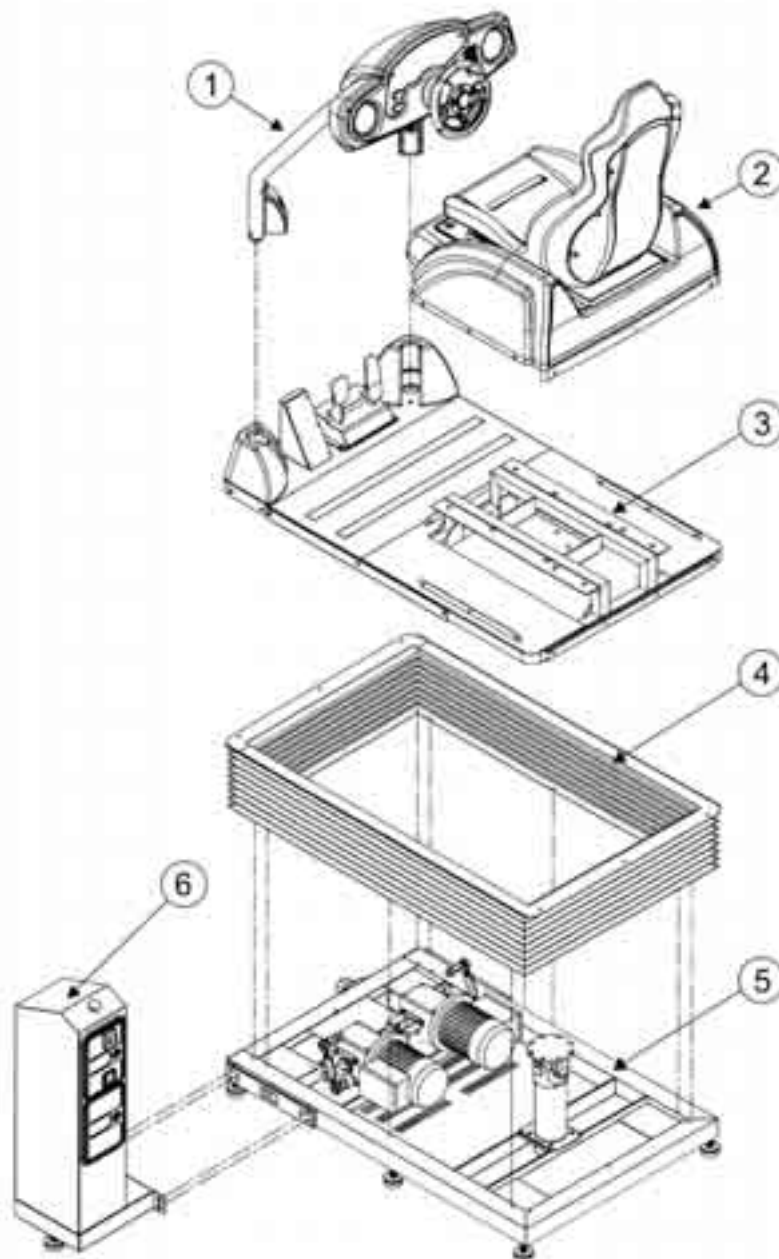

**10.11 DASHBOARD ASSEMBLY - 1**

	CODE	DESCRIPTION
1	TOK-833	TUBULAR STRUCTURE
2	TOK-852	STEERING MECHANISM
3	TOK-806	BACK COVER, BLACK
4	TOK-833	4" LOUDSPEAKER, 4Ω / 60W - 2 WAY, code 35.1367
5	TOK-865	LOUDSPEAKER COVER, code 11.0349
6	TOK-881	KEYPAD AK707
7	TOK-882	FRAME, keypad
8	TOK-808	SAFETY COVER, tubes
9	--	SCREW UM1001 M6X10
10	--	SCREW DIN912 M8X20
11	--	SPRING WASHER DIN127 M8
12	--	FLAT WASHER DIN125 M8
13	--	SCREW DIN912 M14X40
14	--	SPRING WASHER DIN127 M14
15	--	FLAT WASHER DIN125 M14
16	--	SCREW DIN912 M8X20
17	--	WASHER DIN6798 M8
18	--	SCREW DIN7981 3,9X20
19	--	SCREW DIN7985 M3X12
20	--	SPECIAL NUT - TRT-M5-1
21	--	SCREW UM1001 M5X10, BLACK
22	--	WASHER DIN6798 M3

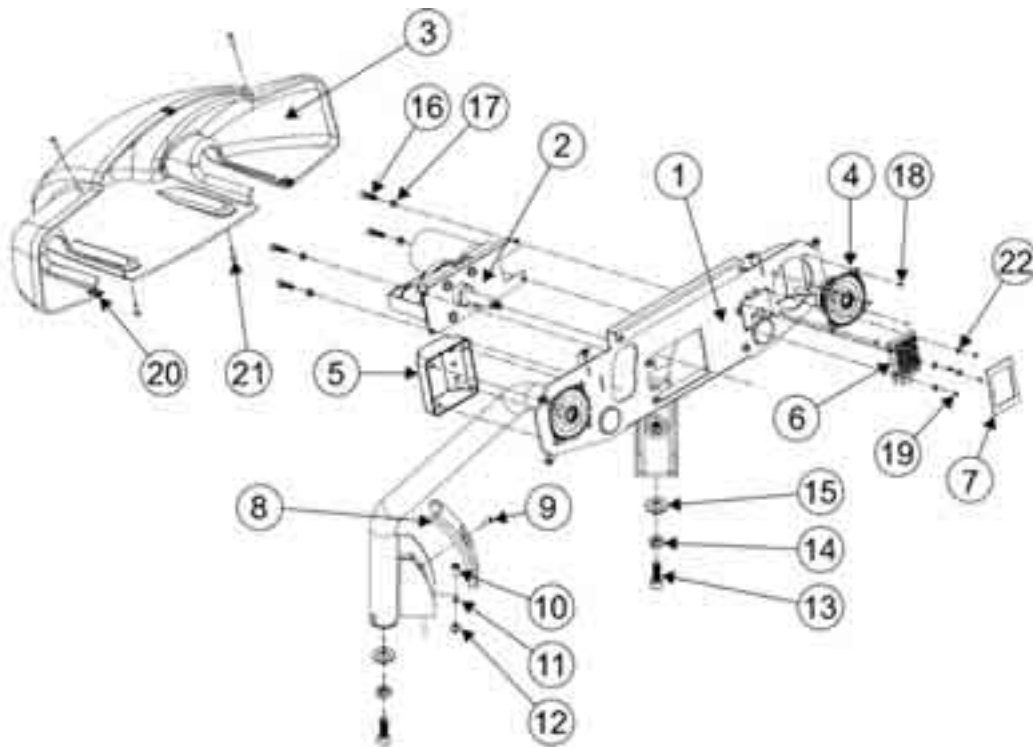

**10.12 DASHBOARD ASSEMBLY - 2**

	CODE	DESCRIPTION
1	TOK-805	FRONT COVER
2	TOK-804	STICKER, instructions
3	TOK-880	PUSH BUTTON AO113, RED, dashboard
4	TOK-853	COUPLING CYLINDER, steering wheel
5	TOK-851	STEERING WHEEL
6	TOK-854	PUSH BUTTON, steering wheel
7	--	WASHER DIN6798A M12
8	--	LOCKNUT DIN985 M12
9	--	WASHER AEF M6
10	--	SCREW DIN912 M6X16
11	--	SCREW ISO7380 M5X10
12	--	CLAMP N-4
13	--	NUT DIN6923 M5

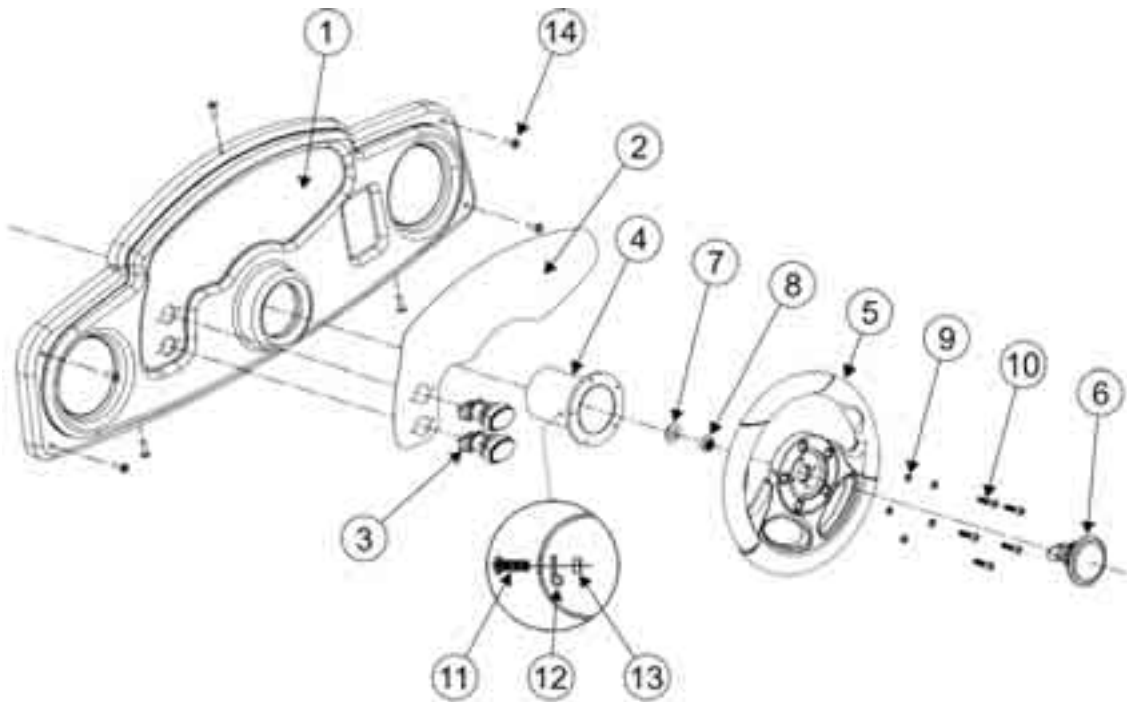

**10.13 STEERING ASSEMBLY – MAIN PARTS**

	<b>CODE</b>	<b>DESCRIPTION</b>
1	C-22-03036	WASHER, belt fastener
2	C-22-0103660	SCREW, belt fastener
3	C-22-0501410	SLEEVE, potentiometer pinion
4	C-22-80025525	KEY WODRUF, steering wheel shaft
5	C-29-401582	MOTOR 20VDC, 3.9A MODEL 1582
6	C-29-405680	POTENTIOMETER 5KW , with PCB (SDR-305)
7	C-40-000300	BEARING HOUSING
8	C-40-022087	PLASTIC PINION, shaft
9	C-40-023097	PLASTIC PINION, potentiometer
10	C-40-025048	MOTOR PULLEY, plastic
11	C-40-085027	BELT 15mm 400/5
12	C-40-203100	SLEEVE, motor pulley
13	C-40-206002	BEARING 6002 ZZ
14	C-40-0250301	OMEGA, belt fastener
15	C-43-050300	GUIDE SLEEVE, self-oil
16	C-GA-TX00010	ATTACHMENT PLATE
17	C-GA-TX00020	MOTOR BRACKET
18	C-GA-TX00030	POTENTIOMETER BRACKET, iron
19	C-GA-TX01010	SHAFT
20	C-GA-QU04060	BEARING Ø20XØ32X7
21	C-GA-TX02010	STOPPER
22	C-GA-TX03600	SHAFT PULLEY, iron
23	C-GA-TX05200	SLEEVE, steering wheel shaft



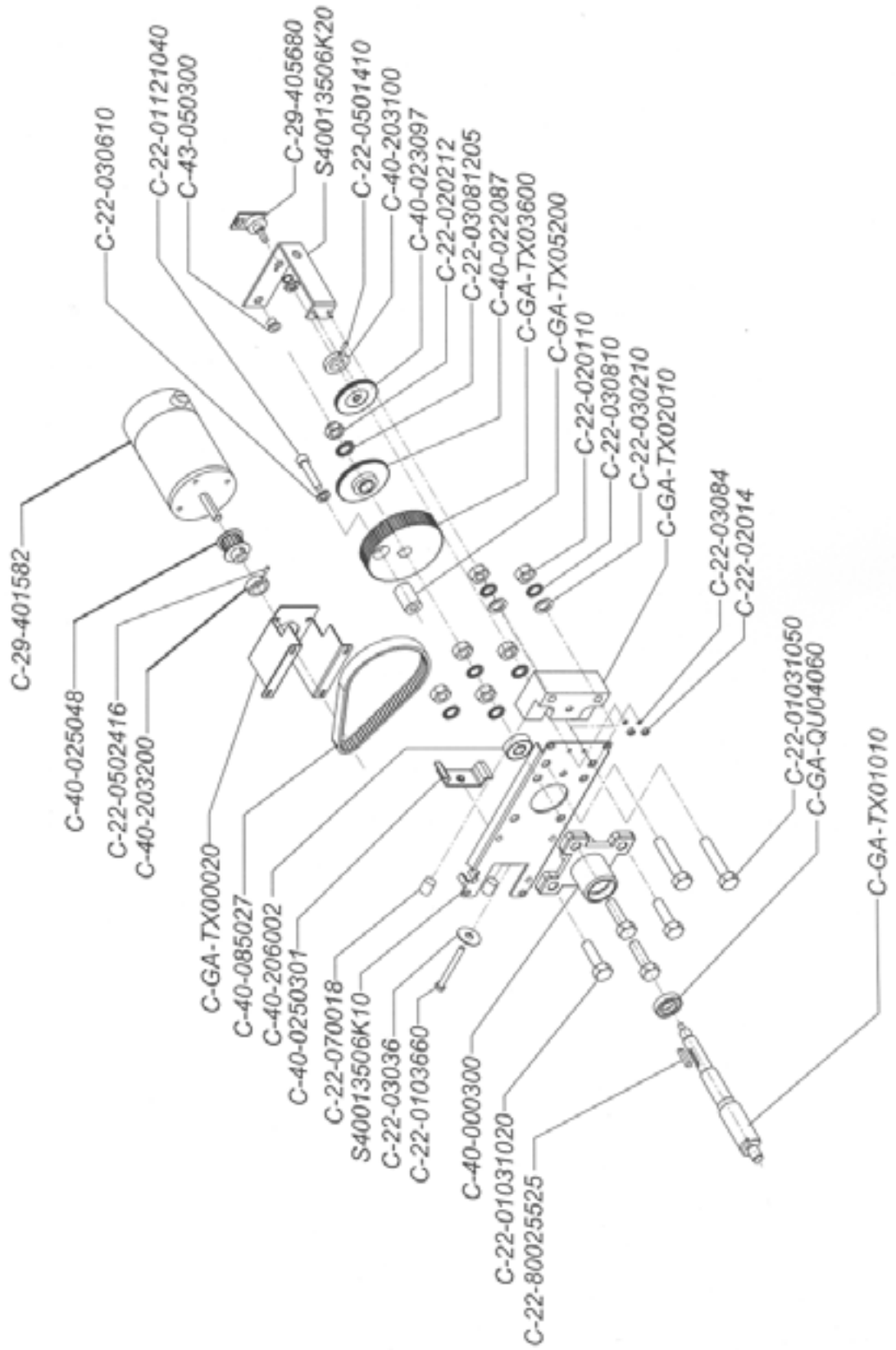

**10.14 PEDALS ASSEMBLY**

	<b>CODE</b>	<b>DESCRIPTION</b>
1	C-11-416020	SPRING, brake pedal
2	C-22-03601218	WASHER Ø12X Ø18X1
3	C-41-605510	SLEEVE PAF-12120 INA P-10
4	C-22-0112520	SCREW DIN912 M5X20
5	C-22-03065	SPRING WASHER DIN7980 M5
6	C-41-605530	SHAFT Ø12X69,5
7	C-22-02014	NUT DIN934 M4
8	S410260010000	BRAKE PEDAL
9	C-22-03044	WASHER M4
10	C-41-605520	SHAFT, microswitch activator Ø10X52
11	C-29-405619	POTENTIOMETER, shaft Ø6X19, KU5021S36HL5K
12	C-22-03014	FLAT WASHER DIN125 M4
13	C-41-604330	BRACKET, potentiometer
14	C-22-038038	WASHER, potentiometer
15	C-22-028038	NUT, potentiometer
16	C-22-0501404	GRUB SCREW DIN913 4X4
17	C-40-401510	PINION , CuZn37, potentiometer
18	C-22-0105418	SCREW DIN7985 M4X18
19	C-41-604320	ACTUATOR SEGMENT, potentiometer
20	S410260020000	ACCELERATOR PEDAL
21	C-22-0115510	SCREW DIN7380 M5X10
22	C-41-605100	RUBBER STOPPER, brake pedal
23	C-41-040306	STOPPER TUBE, ADIPRENE
24	C-22-06064	SPRING WASHER DINT7980 M4
25	C-11-416010	SPRING, accelerator pedal
26	C-22-0105410	SCREW DIN7985 M4X10
27	C-22-03084	WASHER DIN6798 M4
28	C-41-601200	BACK COVER AP-02
29	C-09-13135	MICROSWITCH CROUZET P-R-L 83.160.3 I W3 (3T)
30	C-22-0105316	SCREW DIN7985 M3X16
31	C-22-03083	WASHER DIN6798 M3
32	C-22-0103660	SCREW DIN933 HEX M6X60
33	S410260440000	BASE ASSEMBLY
34	C-22-03066	SPRING WASHER DIN7980 M6
35	C-22-02016	NUT DIN934 M6
36	C-41-601100	FRONT COVER AP-02
37	C-41-040207	STOPPER TUBE, PVC
38	C-41-040200	SPACER SLEEVE

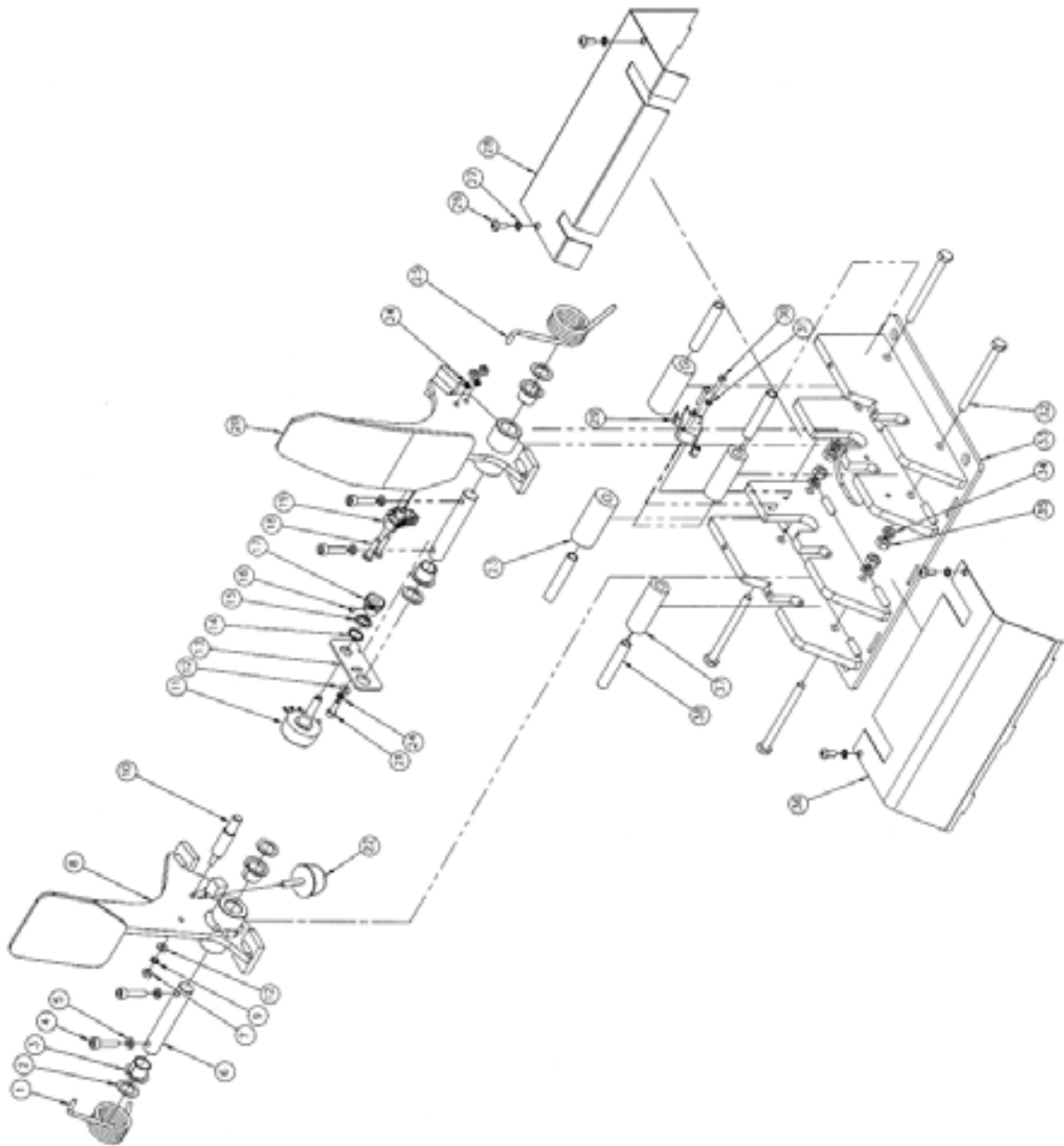

**10.15 SEAT ASSEMBLY**

---

	<b>CODE</b>	<b>DESCRIPTION</b>
1	TOK-801	SEAT
2	TOK-837	PROTECTION PLATE
3	TOK-885	HANDLE, seat slides
4	TOK-838	SUPPORTING PLATE, seat
5	TOK-803	PLASTIC COVER
6	TOK-802	BACK COVER, seat
7	TOK-813	STICKER, back cover
8	--	SCREW DIN7981 3,9X16
9	--	SPRING WASHER DIN127 M8
10	--	SCREW DIN912 M8X16
11	--	SCREW DIN912 M8X20
12	--	SCREW UM1001 M8X20 BLACK
13	--	SCREW UM1001 M5X10
14	--	FLAT WASHER DIN125 M8
15	--	SPRING WASHER DIN127 M8
16	--	NUT DIN934 M8
17	TOK-887	SEAT SLIDE - LEFT
18	TOK-886	SEAT SLIDE - RIGHT
19	TOK-812	BASE STICKER - RIGHT
20	TOK-811	BASE STICKER - LEFT
21	TOK-814	BASE STICKER - REAR

---

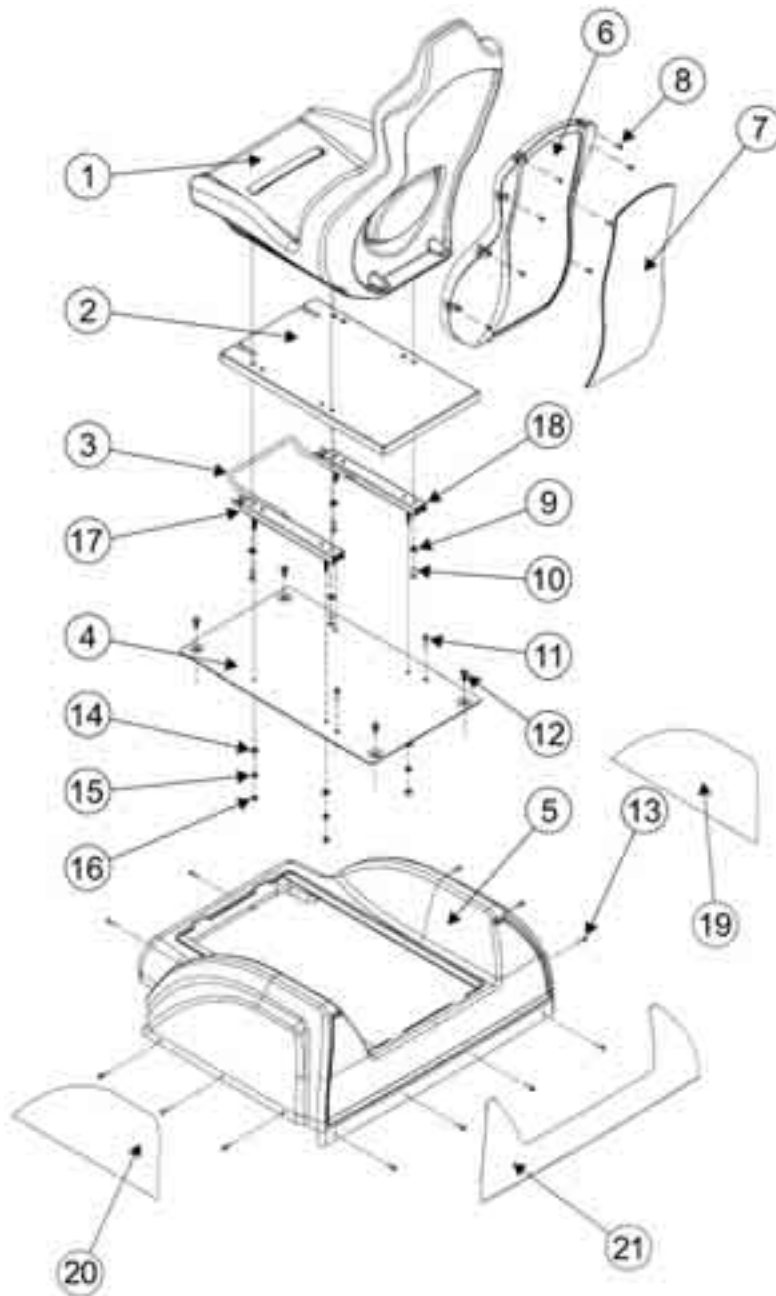

**10.16 MOBILE PLATFORM ASSEMBLY**

	CODE	DESCRIPTION
1	TOK-832	PLATFORM
2	TOK-860	PEDALS ASSEMBLY
3	TOK-836	METALIC COVER, access to motors
4	TOK-810	PROTECTION FOLDING HOOD
5	TOK-846	BRACKET, protection folding hood
6	TOK-807	PLASTIC COVER, tubes
7	--	SCREW DIN912 M12X30
8	--	FLAT WASHER DIN125 M12
9	--	FLAT WASHER DIN125 M12
10	--	NUT DIN985 M12
11	--	SCREW UM1001 M8X20 BLACK
12	--	SCREW UM1001 M6X16
13	--	SCREW UM1001 M6X16
14	--	SCREW UM1001 M6X16
15	--	SCREW UM1001 M6X10
15	TOK-869	SAFETY WALK BAND - 50mm width

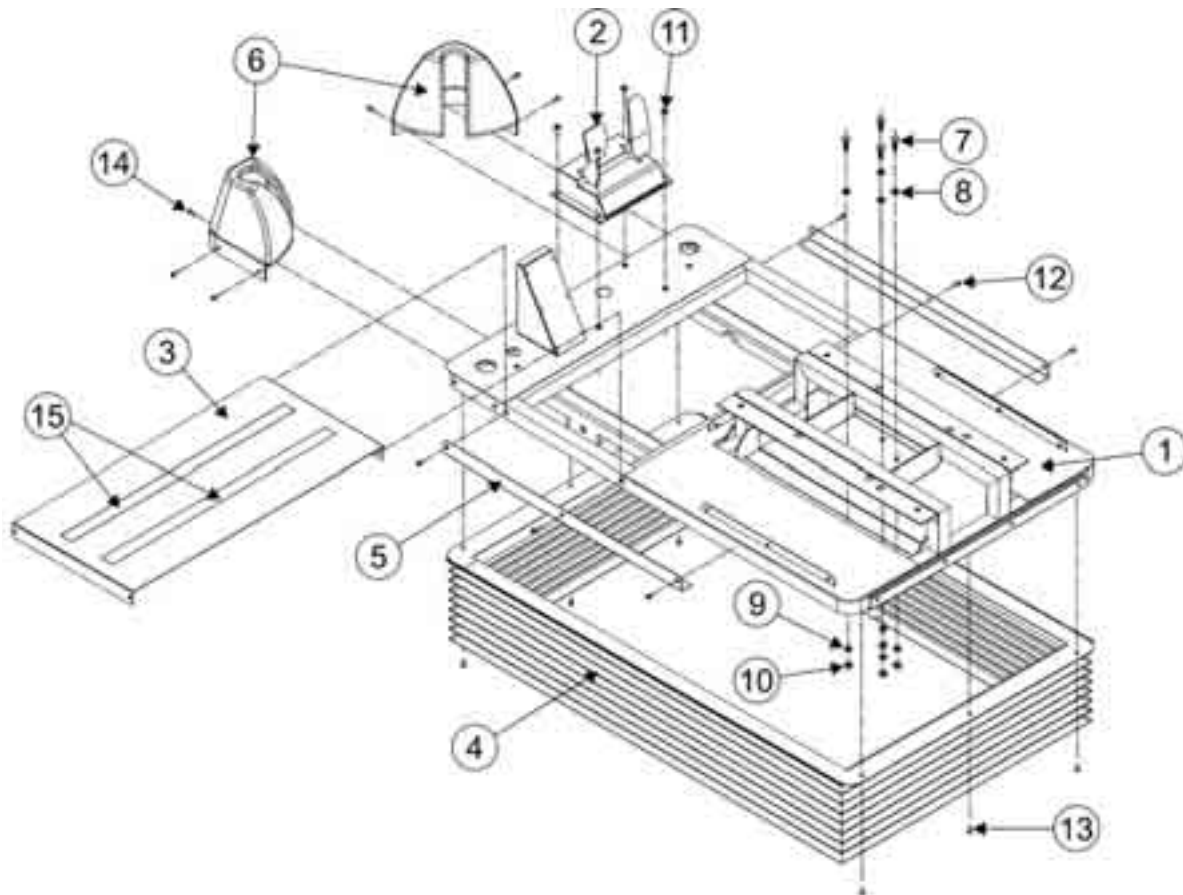

**10.17 BASE ASSEMBLY**

	CODE	DESCRIPTION
1	TOK-831	BASE
2	TOK-839S	CARDAN ASSEMBLY
3	TOK-821	MOTOR ASSEMBLY - LEFT
4	TOK-820	MOTOR ASSEMBLY - RIGHT
5	TOK-810	PROTECTION FOLDING HOOD
6	TOK-863	SWIVELING CASTOR Ø80
7	TOK-862	CASTOR Ø80
8	TOK-861	LEG LEVELLER, rubber base Ø60, M16
9	--	SCREW DIN912 M12X30
10	--	SPRING WASHER DIN127 M12
11	--	SCREW DIN933 M8X20
12	--	SPRING WASHER DIN127 M8
13	--	FLAT WASHER DIN125 M8
14	--	SCREW UM1001 M6X16
15	--	NUT DIN985 M8

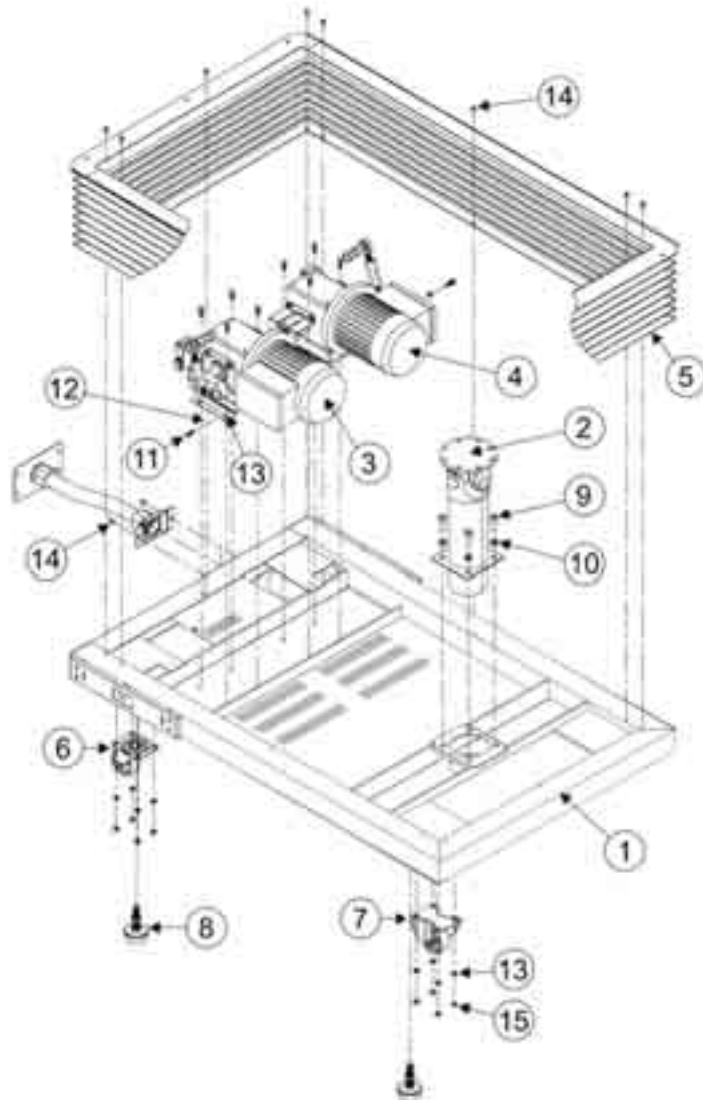

**10.18 MOTOR ASSEMBLY**

	CODE	DESCRIPTION
1	--	GEARED MOTOR - LEFT: TOK-821 / RIGHT: TOK-820
2	TOK-827	SHAFT CRANK, motor trasmission
3	TOK-826	HEXAGONAL ROD, motor transmission
4	TOK-825	SWIVEL JOINT, male M14 + male M16, SBA-0418
5	TOK-841N	SUPPORTING PLATE, motor
6	TOK-829	CENTERING SCREW, elastic coupling
7	TOK-819	ELASTIC COUPLING - RIGHT: TOK-819R / LEFT: TOK-819L
8	TOK-848	BRACKET, potentiometer
9	TOK-855	POTENTIOMETER - GAELCO
10	--	SCREW DIN912 M8X12
11	--	SPRING WASHER DIN127 M8
12	--	NUT DIN934 M14
14	--	LOCKNUT DIN985 M16
15	--	SCREW DIN933 M10X70
16	--	FLAT WASHER DIN125 M10
17	--	SPRING WASHER DIN127 M10
18	--	NUT DIN934 M10
19	--	SCREW DIN933 M10X30
20	--	WASHER DIN9021 M10
21	--	SCREW DIN933 M8X20
22	--	WASHER DIN6798 A 8,2

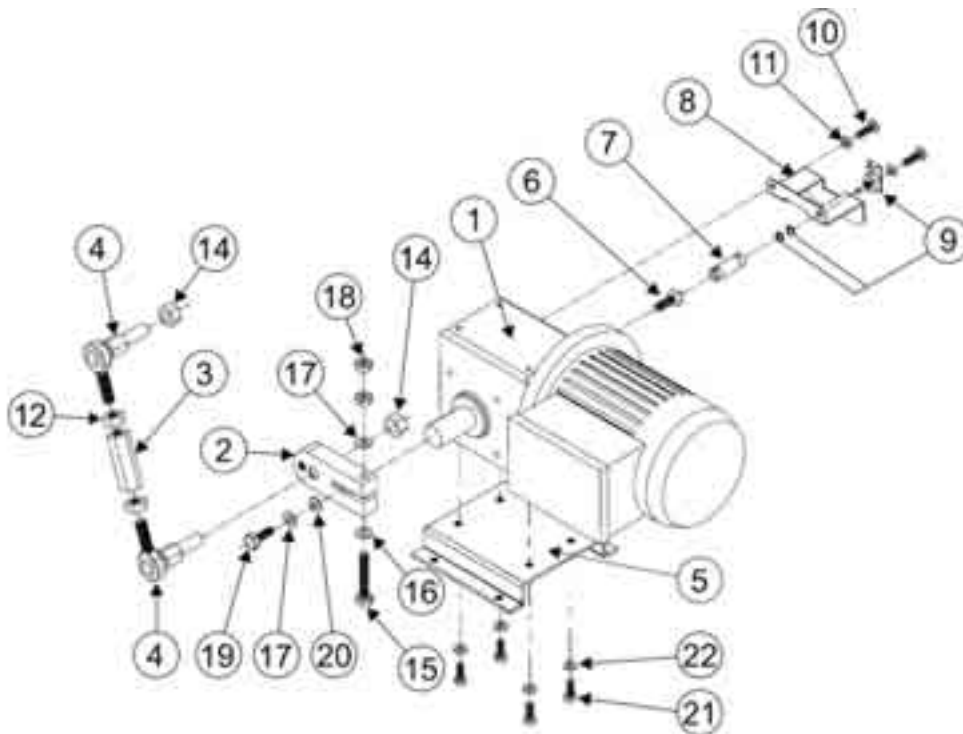



**10.19 COIN TOWER ASSEMBLY**

	CODE	DESCRIPTION
1	TOK-834	TOWER
2	TOK-835	TOWER BASE
3	TOK-861	LEG LEVELLER rubber base Ø60, M16
4	TOK-410	DOUBLE FRAME MINIDOOR 1E
5	TOK-817	EMERGENCY STOP BUTTON
6	TOK-299	TEST PANEL
7	--	SCREW ISO7380 M4X8 BLACK
8	--	WASHER DIN6798 M4
9	--	SCREW DIN912 M10X20
10	--	SPRING WASHER DIN127 M10
11	--	FLAT WASHER DIN125M10

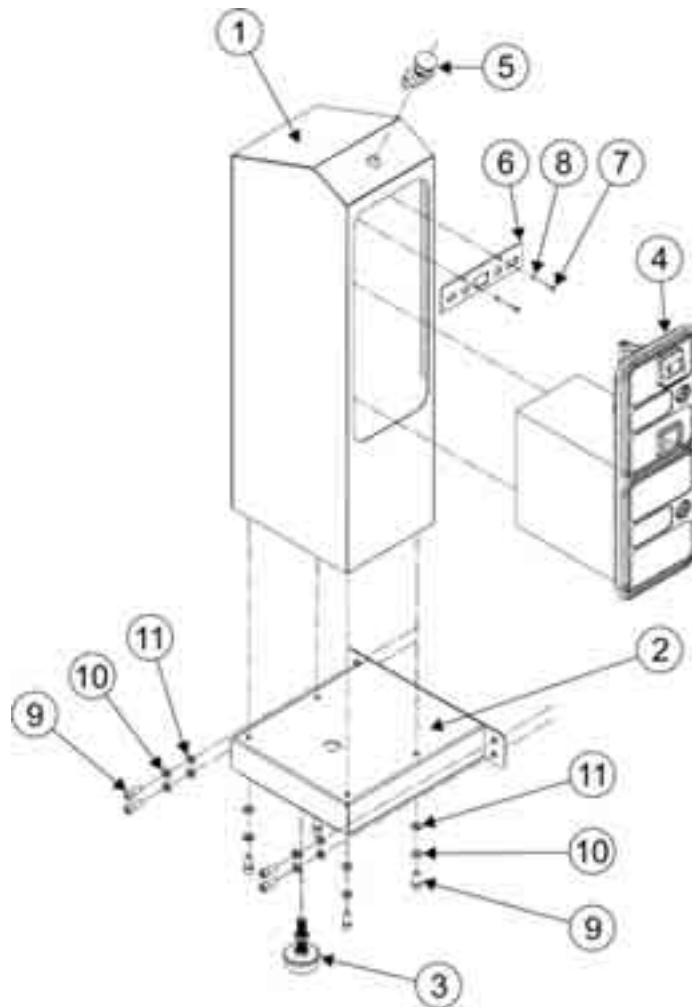



## 11. WIRING DIAGRAMS

### 11.1 POWER WIRING DIAGRAM

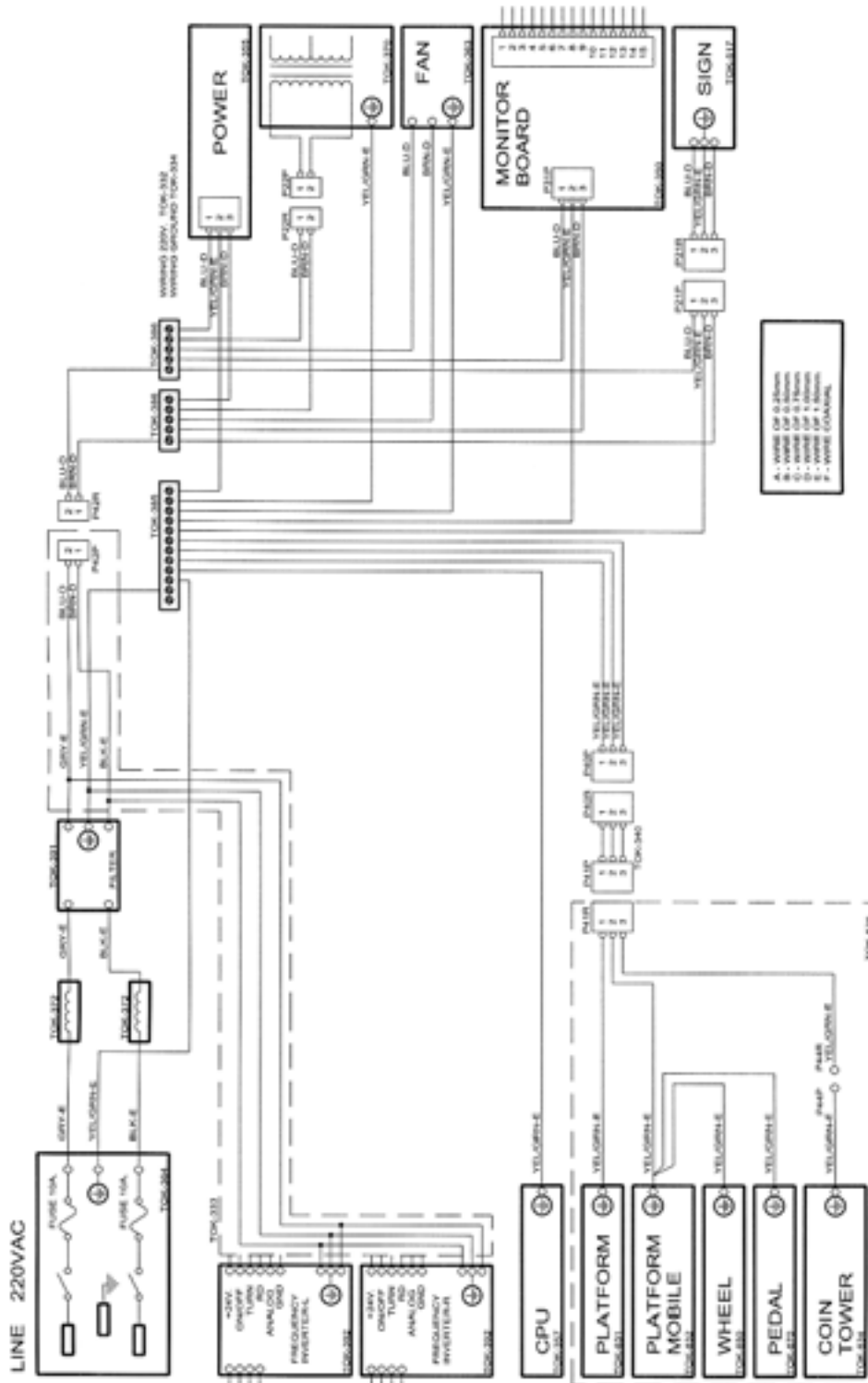

11.2 CABINET WIRING DIAGRAM

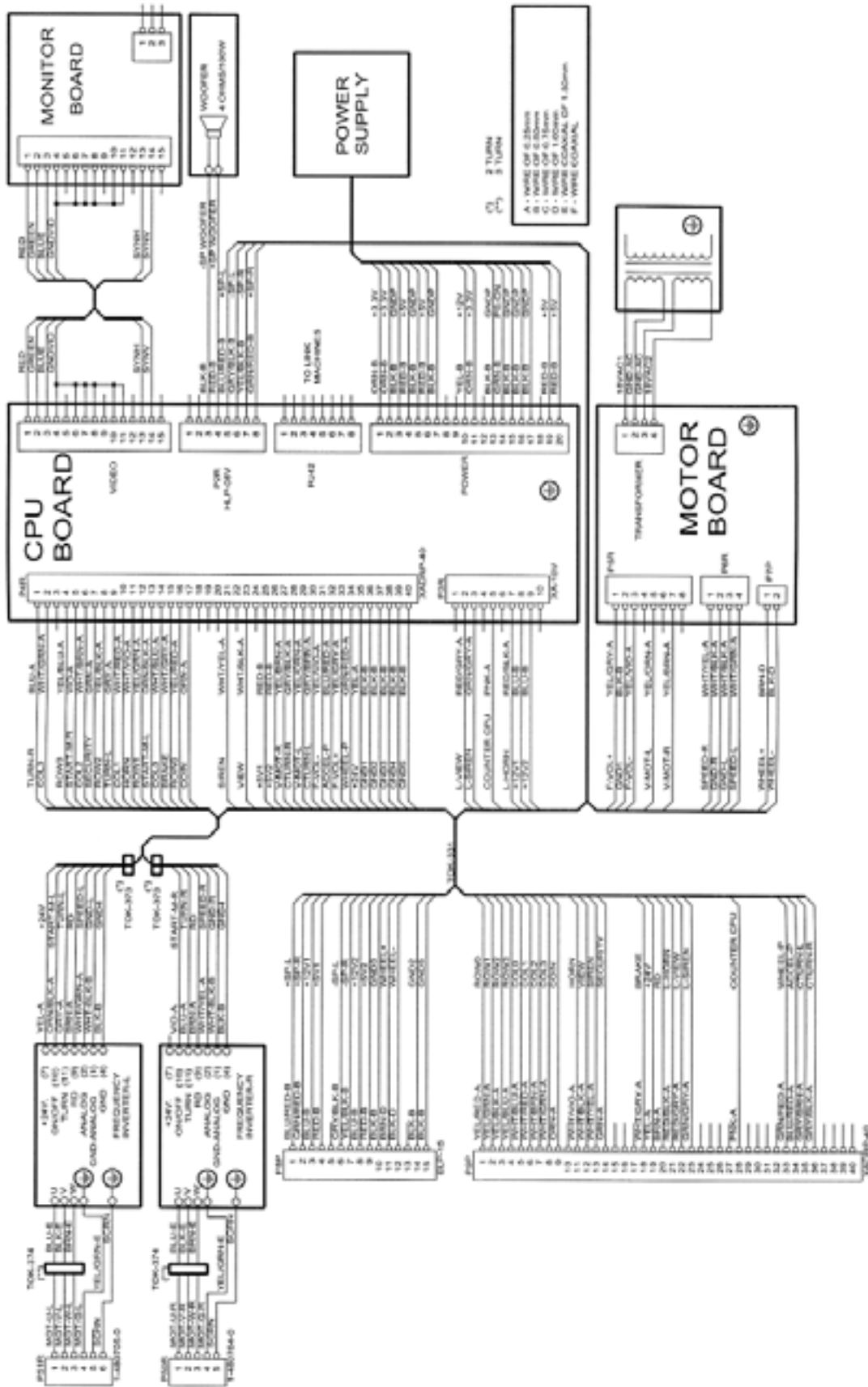

11.3 UNION HARNESS WIRING DIAGRAM

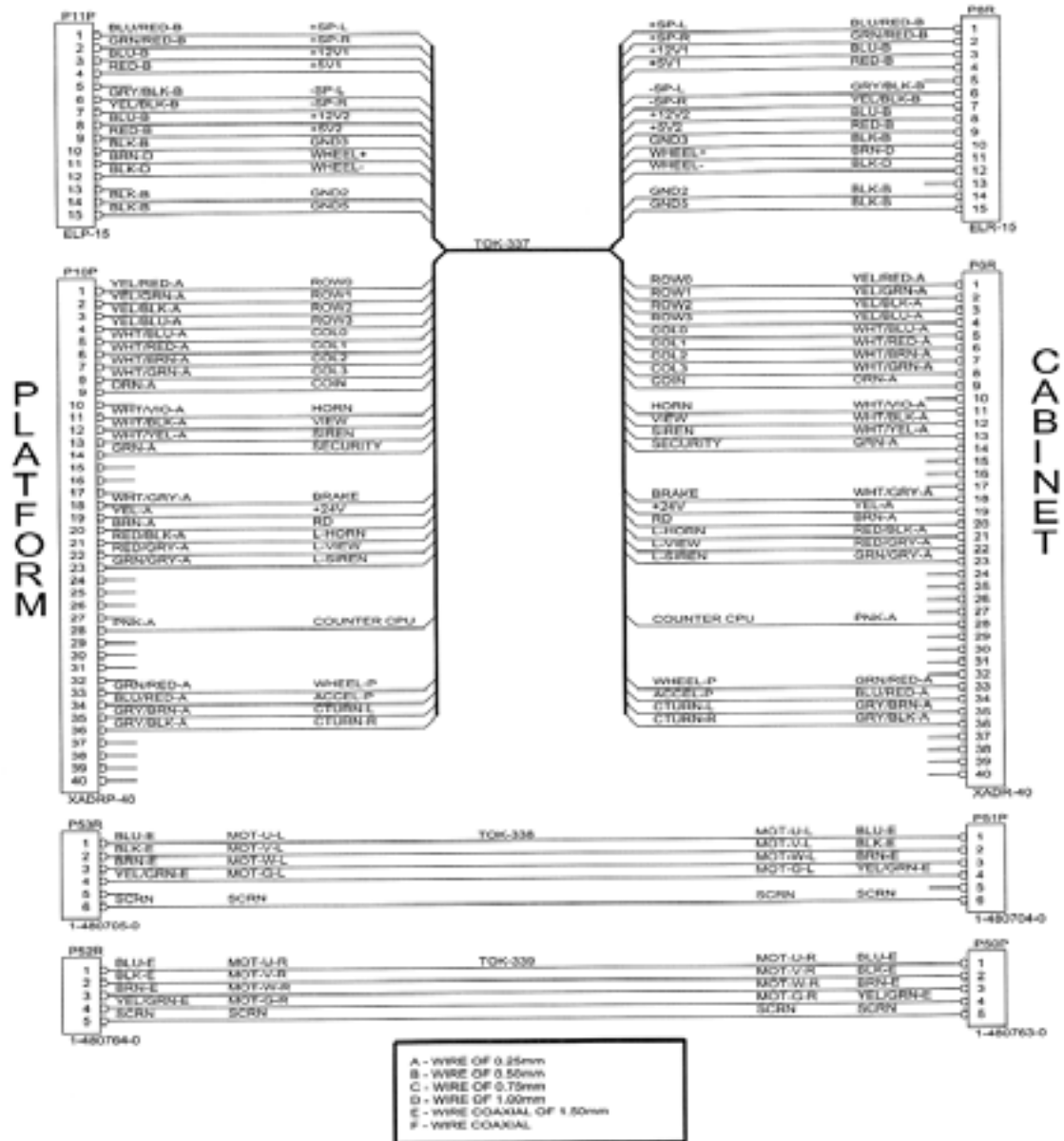

11.4 PLATFORM WIRING DIAGRAM

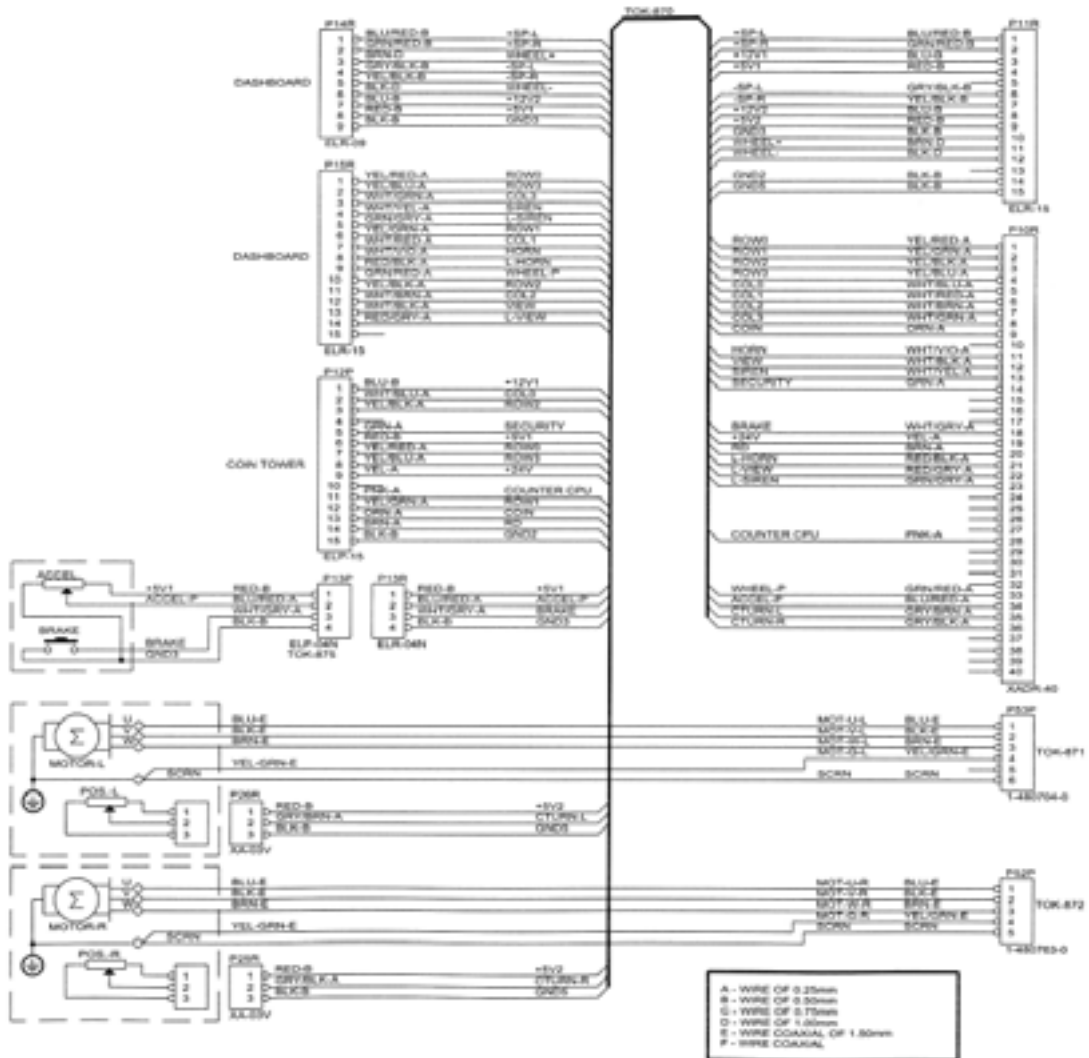

## 11.5 DASHBOARD WIRING DIAGRAM

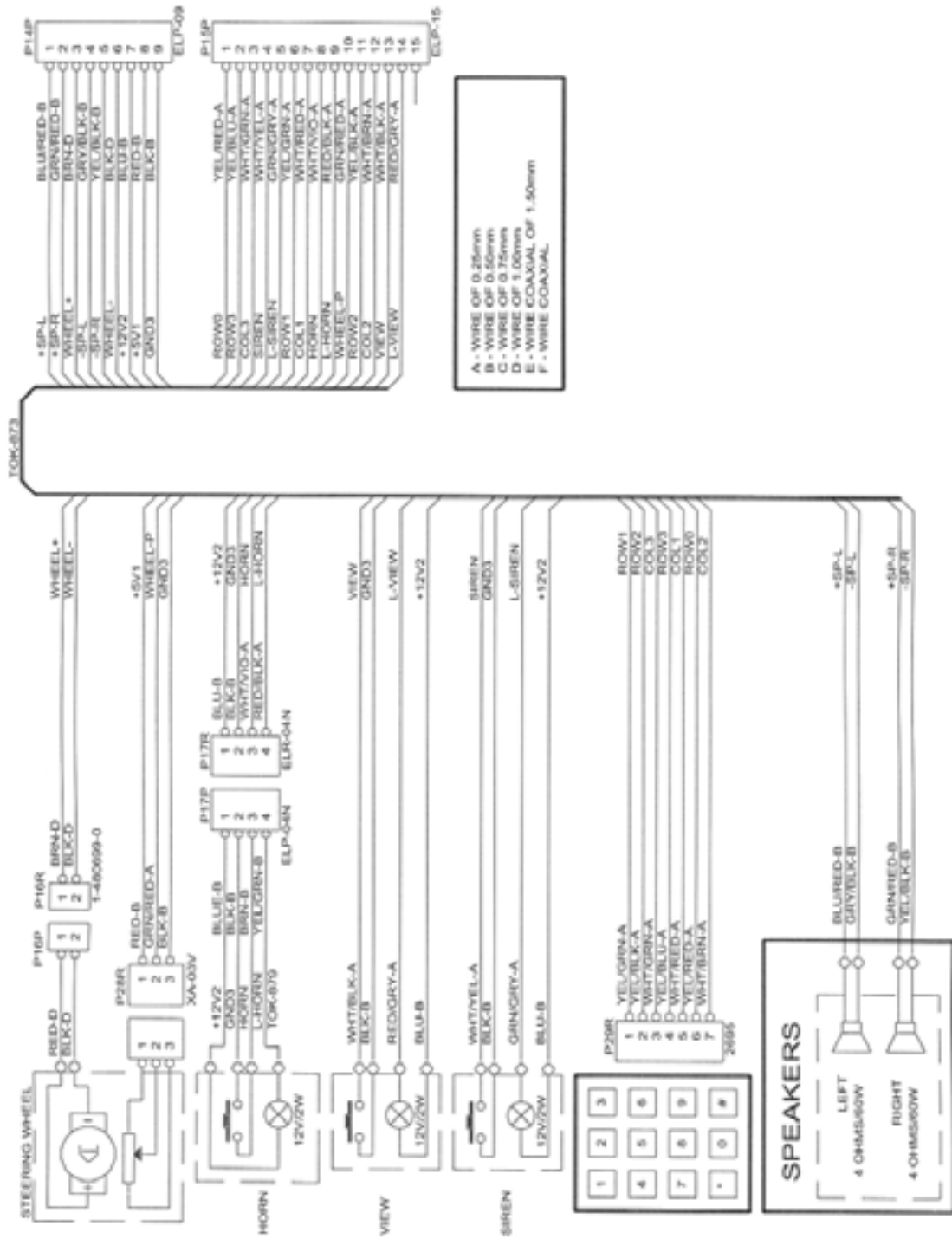

11.6 COIN TOWER WIRING DIAGRAM

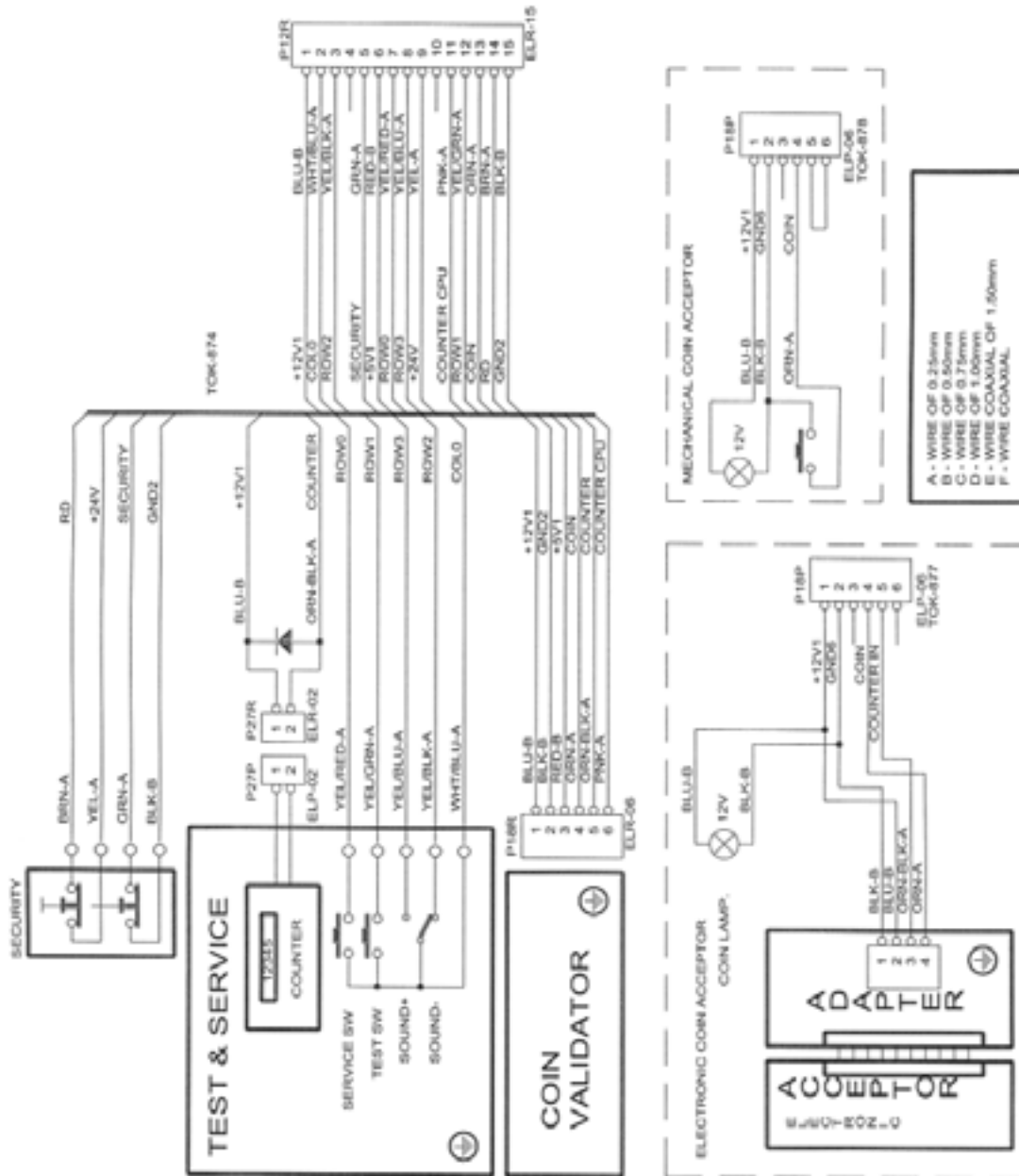



## 12. CREDIT DISTRIBUTOR SETUP

**JP1:Not used**  
**JP2:Cabinet**  
**JP3:Coin controller**  
**JP4:Not used**



**Connector JP2:** This connector should be connected to ATV PCB wiring

JP2	Description	Values	Source/Destination
Pin 1	Input GND	GND	GND power supply
Pin 2	Input VDC	+12 VDC	DC power supply
Pin 3	Counter output	0/+5/+12 VDC	Coin counter
Pin4	Credits output	+5/0 VDC	Credits for CPU

**Connector JP3:** Input connector of electronic coin controller. Setup per channel.

PIN	Signal	Active
1	0V	0V
2	+12VDC	+12VDC
3	Output 5	0V
4	Output 6	0V
5	- - -	
6	Lock	High
7	Output 1	0V
8	Output 2	0V
9	Output 3	0V
10	Output 4	0V

9	7	5	3	1
10	8	6	4	2

(As seen from components side)

**PROGRAMMING OF COIN CONTROLLERS**

Controllers supported: COIN CONTROL C-120  
 NRI G-13.6000  
 MARS CASHFLOW 330

MARS 330/S 212	OPA	OPB	OPC	OPD	OPE	OPF
NRI G-13.6000	Channel 1	Channel 2	Channel 3	Channel 4	Channel 5	Channel 6
Coin Control C 120	Coin 1	Coin 2	Coin 3	Coin 4	Coin 5	Coin 6
<b>PIN Controller:</b>	<b>7</b>	<b>8</b>	<b>9</b>	<b>10</b>	<b>3</b>	<b>4</b>
USA	= =	= =	= =	1 \$	50 Ct	25 Ct
Great Britain	= =	1 £	50 Pen	= =	20 Pen	10 Pen
Australia	= =	= =	5 \$	= =	2 \$	1 \$
Switzerland	= =	= =	5 Fr	= =	2 FS	1 FS
Sweden	= =	10 Kr	5 Kr	= =	= =	1 Kr
Norway	20 Kr	10 Kr	5 Kr	= =	= =	1 Kr
EURO €	2€	1€	50c	= =	20c	10c

**SWITCH SETUP FOR EUROS**

**SW1:** Always OFF

**SW2:** Always OFF

**SW3:** Not used

**SW4-SW5: Extra Credits (Bonuses)**

Combinations of this two dip switches are used to program bonuses (free games) according to the scale shown in the table. The table varies according to the game price selected.

**SW6-SW7-SW8: Game Price**

These dip switches are used to choose the game price. The bonus table shows the combination of game prices with the payments that allow the player to obtain extra games (bonuses).

CREDITS table				BONUS table (SW4/SW5)			
SW6	SW7	SW8	Value/Credit	OFF/OFF	ON/OFF	OFF/ON	ON/ON
OFF	OFF	OFF	10c	No bonus	50c	40c	20c
ON	OFF	OFF	20c	No bonus	50c	40c	20c
OFF	ON	OFF	30c	No bonus	*50c	30c	60c
ON	ON	OFF	40c	No bonus	2€	1,6€	80c
OFF	OFF	ON	50c	No bonus	2,5€	2€	1€
ON	OFF	ON	80c	No bonus	2€	1,6€	80c
OFF	ON	ON	1€	No bonus	2,5€	2€	1€
ON	ON	ON	1,2€	No bonus	2€	1,6€	2,4€

(\*) Add another credit for the second lap.

**APPLICATION EXAMPLES**

---

**Game price: 50c, NO BONUS**

Switch set up:

<b>SW1</b>	<b>SW2</b>	<b>SW3</b>	<b>SW4</b>	<b>SW5</b>	<b>SW6</b>	<b>SW7</b>	<b>SW8</b>
<b>OFF</b>	<b>OFF</b>	<b>OFF</b>	<b>OFF</b>	<b>OFF</b>	<b>OFF</b>	<b>OFF</b>	<b>ON</b>

**Game price: 50c, BONUS FOR 2 € (4 credits + 1 credit free)**

Switch setup:

<b>SW1</b>	<b>SW2</b>	<b>SW3</b>	<b>SW4</b>	<b>SW5</b>	<b>SW6</b>	<b>SW7</b>	<b>SW8</b>
<b>OFF</b>	<b>OFF</b>	<b>OFF</b>	<b>OFF</b>	<b>ON</b>	<b>OFF</b>	<b>OFF</b>	<b>ON</b>

**Game price: 1 € , NO BONUS**

Switch setup:

<b>SW1</b>	<b>SW2</b>	<b>SW3</b>	<b>SW4</b>	<b>SW5</b>	<b>SW6</b>	<b>SW7</b>	<b>SW8</b>
<b>OFF</b>	<b>OFF</b>	<b>OFF</b>	<b>OFF</b>	<b>OFF</b>	<b>OFF</b>	<b>ON</b>	<b>ON</b>

**Game price: 1 € , BONUS FOR 2,5 € (2 credits + 1 credit free)**

Switch setup:

<b>SW1</b>	<b>SW2</b>	<b>SW3</b>	<b>SW4</b>	<b>SW5</b>	<b>SW6</b>	<b>SW7</b>	<b>SW8</b>
<b>OFF</b>	<b>OFF</b>	<b>OFF</b>	<b>ON</b>	<b>OFF</b>	<b>OFF</b>	<b>OFF</b>	<b>ON</b>

**SWITCH SETUP FOR OTHERS CURRENCIES**

---

**SW1:** Always OFF

**SW2:** Coin multiplication factor

<b>SW2=OFF</b> Euro $\text{¤}$ , and rest of Europe	<b>Chanel:</b>	<b>1</b>	<b>2</b>	<b>3</b>	<b>4</b>	<b>5</b>	<b>6</b>
	<b>Value:</b>	<b>X20</b>	<b>X10</b>	<b>X5</b>	<b>X4</b>	<b>X2</b>	<b>X1</b>
<b>SW2=ON</b> (USA)	<b>Chanel:</b>	<b>1</b>	<b>2</b>	<b>3</b>	<b>4</b>	<b>5</b>	<b>6</b>
	<b>Value:</b>	<b>X20</b>	<b>X10</b>	<b>X8</b>	<b>X4</b>	<b>X2</b>	<b>X1</b>

**SW3:** Not used

**SW4-SW5: Extra Credits (Bonuses)**

Combinations of these two dip switches are used to program bonuses (free games) according to the scale shown in the table. The table varies according to the game price selected.

**SW6-SW7-SW8: Game Price**

These dip switches are used to choose the game price. The bonus table shows the combination of game prices with the payments that allow the player to obtain extra games (bonuses).

CREDITS table				BONUS table (SW4/SW5)			
SW6	SW7	SW8	Value/Credit	OFF/OFF	ON/OFF	OFF/ON	ON/ON
OFF	OFF	OFF	1	0	5	4	2
ON	OFF	OFF	2	0	5	4	2
OFF	ON	OFF	3	0	*5	3	6
ON	ON	OFF	4	0	20	16	8
OFF	OFF	ON	5	0	25	20	10
ON	OFF	ON	8	0	20	16	8
OFF	ON	ON	10	0	25	20	10
ON	ON	ON	12	0	20	16	24

(\*) Adds another credit for the second lap.

**APPLICATION EXAMPLES****Example 1**

<b>Switzerland</b>	SW1 =	OFF	SERIAL input. (5 FS via PIN 5) = (Channel 3)
	SW2 =	OFF	Input values x1 x2 — x5
	SW3 =		Not used
	SW4 =	OFF	EXTRA credit on the 20th pulse (=20FF)
	SW5 =	ON	
1 FF = 1 pulse	SW6 =	OFF	5 pulses / 1 credit.
	SW7 =	OFF	
	SW8 =	ON	
<b>RESULTS:</b>	5 FS / 1 credit; 20 FS / 5 credits		

**Example 2**

<b>Sweden</b>	SW1 =	OFF	SERIAL input. (5 Kr via PIN 5) = (Channel 3)
	SW2 =	OFF	Input values x1 x2 — x5
	SW3 =		Not used
	SW4 =	OFF	EXTRA credit on the 20th pulse (=20FF)
	SW5 =	ON	
1 Kr = 1 pulse	SW6 =	OFF	5 pulses / 1 credit.
	SW7 =	OFF	
	SW8 =	ON	
<b>RESULTS:</b>	5 Kr / 1 credit; 20 Kr / 5 credits		

**Example 3**

<b>Norway</b>	SW1 =	OFF	SERIAL input. (5 Kr via PIN 5) = (Channel 3)
	SW2 =	OFF	Input values x1 x2 — x5
	SW3 =		Not used
	SW4 =	ON	EXTRA credit on the 25th pulse (=20Kr)
	SW5 =	OFF	
1 Kr = 1 pulse	SW6 =	OFF	10 pulses / 1 credit.
	SW7 =	ON	
	SW8 =	ON	
<b>RESULTS:</b>	10 Kr / 1 credit; 25 Kr / 3 credits		

**Example 4**

<b>Great Britain</b>	SW1 =	OFF	SERIAL input. (10 Pen via PIN 8) = (Channel 6)
	SW2 =	OFF	Input values x1 x2 — x5
	SW3 =		Not used
	SW4 =	ON	EXTRA credits on the 5th pulse (=50 Pen)
	SW5 =	OFF	and 10th pulse (1 £)
1 Pen = 1 pulse	SW6 =	OFF	3 pulses / 1 credit.
	SW7 =	ON	
	SW8 =	OFF	
<b>RESULTS:</b>	30 Pen / 1 credit; 50 Pen / 2 credits; 1 £ / 5 credits		