

IKARI WARRIORS

SERVICE
INSTRUCTIONS

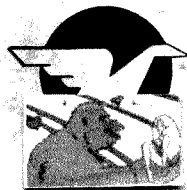

TRADEWEST

TRADEWEST, INC.
2400 SOUTH HWY. 75
CORSIANA, TEXAS 75110

214-874-2683

IKARI WARRIORS

TABLE OF CONTENTS

I. GENERAL INFORMATION:

User F.C.C. Information - - - - -	1
Introduction - - - - -	2
Game & Play Instructions - - - - -	3

II. OPERATION:

Game Optional Dip Switch Settings - - - - -	4
Installation & Electrical Requirements - - - - -	6
Routine Maintenance & Service - - - - -	7
On-Board Diagnostics - - - - -	8

III. GAME DRAWINGS & WIRING DIAGRAMS:

P.C. Board & Rotary SW Ass'y (Figure-1) - - - - -	11
Joystick Ass'y, Exploded view (Figure-2) - - - - -	12
Monitor Conversion (Figure-3) - - - - -	13
Game Board Conversion, Cabinet view (Figure-4) - -	14
Chassis Ground Layout, Cabinet view (Figure-5) - -	15
Control Panel GND Harness Conversion (Figure-6) - -	16
Interface Wiring Board Layout (Figure-7) - - - - -	17
Interface Board To Edge Connector Diagram - - - - -	18
Universal Video Hardware System Drawing - - - - -	19

USER INFORMATION - F.C.C.

WARNING

THIS EQUIPMENT GENERATES, USES, AND CAN RADIATE RADIO FREQUENCY ENERGY AND IF NOT INSTALLED AND USED IN ACCORDANCE WITH THE INSTRUCTIONS MANUAL, MAY CAUSE INTERFERENCE TO RADIO COMMUNICATIONS.

IT HAS BEEN TESTED AND FOUND TO COMPLY WITH THE LIMITS FOR A CLASS "A" COMPUTING DEVICE PURSUANT TO SUB-PART J OF PART 15 OF F.C.C. RULES, WHICH ARE DESIGNED TO PROVIDE REASONABLE PROTECTION AGAINST SUCH INTERFERENCE WHEN OPERATED IN A COMMERCIAL ENVIROMENT.

OPERATION OF THIS EQUIPMENT IN A RESIDENTIAL AREA IS LIKELY TO CAUSE INTERFERENCE IN WHICH CASE THE USER AT HIS OWN EXPENSE WILL BE REQUIRED TO TAKE WHATEVER MEASURES MAY BE REQUIRED TO CORRECT THE INTERFERENCE.

INTRODUCTION

"IKARI WARRIORS" is a microprocessor based coin-operated electronic game that makes extensive use of digital integrated circuitry and television monitor concepts. This Manual is designed for the use of maintenance technicians who possess a general knowledge of solid-state circuitry and video monitor theory. Any individual NOT knowledgeable in these areas SHOULD NOT attempt repair of the electronic portions of the game.

In addition to this manual and training in electronics, troubleshooting and repair will be facilitated by access to general-type handtools, a multimeter, a 50 or 100 MHZ oscilloscope and a logic probe would be helpful.

Technical assistance is available by calling (214) 872-8477.

Questions or comments concerning "IKARI WARRIORS" are welcome and should be directed to:

TRADEWEST, INC.
2400 South Highway 75
Corsicana, Texas 75110

This Game comes in a cabinet equipped with DYNAMO's Universal Video Hardware System. It provides the needs for additional Game conversion.

With the aid of an Interface Wiring Board (supplied), Game conversion is made by matching and soldering the GAME P.C. Board functions with the Cabinet Universal Video Hardware System. All jumper and wire soldering is done on the Interface Wiring Board. For Interface Wiring Board information refer to Figure 7 of this Manual.

UNIVERSAL CONTROL PANELS FOR GAME CONVERSION ARE AVAILABLE UPON REQUEST THROUGH DYNAMO CORPORATION SALES DEPARTMENT.

CONTACT: Dynamo Corporation
2525 Handley-Ederville Rd.
Richland Hills, Texas 76118
(817) 589-7699

GAME INSTRUCTIONS

OBJECTIVE: TO REACH THE VILLAGE OF "IKARI".

The enemy forces have a strong army of defense, with tanks, amphibious units, helicopters, and ground troops. The ground is further enforced with armored bunkers which must be destroy. Five gates stand in the way along the route. Proceed to the next area by destroying each gate. Use grenade for heavy enemy action and clearing barricades. Remaining bullets are display on the upper left corner. Collect "POW" along the way when bullets are running low. Fuel gage on the left corner indicates remaining fuel. Collect "GAS" to recover fuel. Tank blows-up when fuel is exhausted.

PLAY INSTRUCTIONS

- * Second player can join game anytime during play.
- * Use Joystick/Rotating Switch Control to move soldiers and direct line of fire.
- * Press Grenade button when over friendly tank with "IN" to get into tank.
- * Use Fire button to fire tank cannon.
- * Use Grenade button to escape from burning tank.
- * Game is over when no soldiers remain or all enemies are destroyed.

OPTIONAL DIP SWITCH SETTINGS

Dip Switch No.1 (8P Dip Switch)

FUNCTION	SW1	SW2	SW3	SW4
Zap friend with grenade	OFF			
Zap friend	ON			
Every BONUS point awarded			OFF	
Only 1st & 2nd BONUS points			ON	
Number of Heroes (3)				OFF
Number of Heroes (5)				ON

CREDITS

COIN	PLAYS	SW5	SW6	SW7	SW8
1	1	OFF	OFF		
2	1	ON	OFF		
3	1	OFF	ON		
4	1	ON	ON		
1	6			OFF	OFF
1	4			ON	OFF
1	3			OFF	ON
1	2			ON	ON

OPTIONAL DIP SWITCH SETTINGS

Dip Switch No.2 (8P Dip Switch)

GAME LEVEL OF DIFFICULTY

Level		SW1	SW2
Easy	1	OFF	OFF
Normal	2	ON	OFF
Hard	3	OFF	ON
Difficult	4	ON	ON

ATTRACTION MODE	SW3	SW4
Audio Mode Off	OFF	OFF
Audio Mode On	ON	OFF
Stop Video Display	OFF	ON
Continuous Play	ON	ON

BONUS

First	Every	SW5	SW6
50,000	100,000	OFF	OFF
60,000	120,000	ON	OFF
100,000	200,000	OFF	ON
NO BONUS		ON	ON

INSTALLATION

YOUR GAME WAS SHIPPED FROM THE FACTORY IN READY-TO-PLAY CONDITION.

A BRIEF INSPECTION IS SUGGESTED BEFORE THE MACHINE IS REMOVED FROM THE CARTON. IF THERE IS DAMAGE TO THE SHIPPING CARTON, CONTACT THE FREIGHT CARRIER FOR CLAIM PURPOSES. EXTERNAL DAMAGE COULD INDICATE POSSIBLE DAMAGE TO THE CABINET AND/OR ELECTRONIC COMPONENTS.

AFTER THE CARTON HAS BEEN SATISFACTORILY INSPECTED, REMOVE THE MACHINE FROM THE SHIPPING CARTON.

EXAMINE THE INTERIOR OF THE GAME FOR DISCONNECTED WIRES, CABLES OR HARNESSSES. MAKE SURE THE ELECTRONIC DEVICES ARE SECURELY MOUNTED IN THEIR SOCKETS, ETC. RECORD ANY PROBLEM AND CONTACT YOUR CUSTOMER SERVICE REPRESENTATIVE FOR TECHNICAL ASSISTANCE.

ELECTRICAL REQUIREMENTS

UNLESS OTHERWISE SPECIFIED, THIS GAME IS SET TO OPERATE AT 110 VOLTS A.C.

ROUTINE MAINTENANCE & SERVICE

Because of the solid state electronic circuitry, This machine should require very little maintenance, and only occasional adjustment. However, it is necessary to take steps to insure this.

The Game volume controls are located on the printed circuit board and can be accessed through the rear cabinet door.

The video monitor was properly adjusted for best color and sharp picture display before shipping. Occasionally minor adjustments are necessary. All adjustment controls for the monitor are located on the rear of the monitor assembly.

This machine should only be adjusted by a "QUALIFIED" Technician.
"DO NOT MAKE ANY ADJUSTMENTS ON THIS MACHINE WHILE THE POWER IS ON!"

POWER SUPPLY

The Computer Board in this game operates most efficiently and reliably when the power supply is set so the voltage on the Board is +5.0 volts. To check voltage, place a digital multimeter across +5 volts (pin-1, pin-2) and ground (pin-41, 42, 43, 44) on the P.C. Board edge connector. Adjust, if necessary, the +5 volt Pot (control) located on the power supply so the meter reads between +4.9 and +5.1 volts.

FOR SERVICE INFORMATION CONTACT:

TRADEWEST, INC
SERVICE DEPARTMENT
STEVE GREEN
(214) 874-2683

P.C. BOARD DIAGNOSTIC TEST

A MANUAL TEST MAY BE PERFORMED BY DEPRESSING THE "PLAYER 1" START BUTTON DURING POWER-UP. WHEN THE "CROSS-HATCH" PATTERN APPEARS, RELEASE THE BUTTON AND PROCEED AS FOLLOWS:

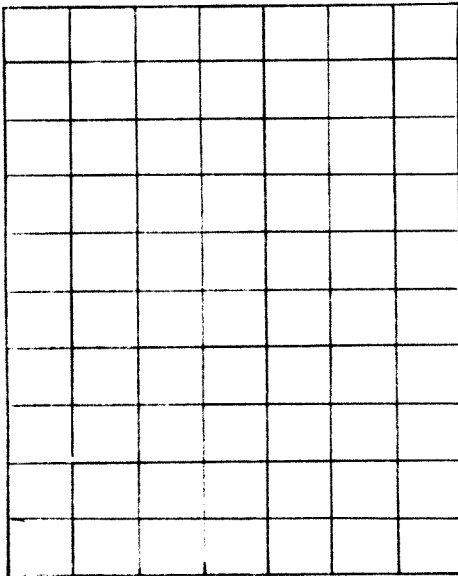

Picture 1 "Cross Hatch"

Adjustment to the monitor may be made to center and/or extend the borders of the picture.

Press "PLAYER 1" button to change to picture 2.

Picture 2 "Color Test"

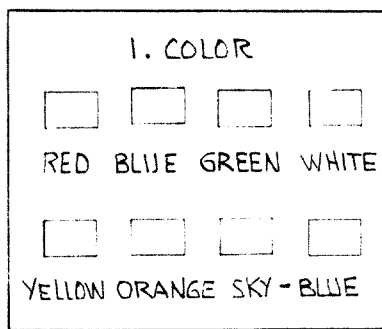

Adjustment of colors on the monitor may be made.

Press "PLAYER 1" button to change to picture 3.

2. LEVER

P1 UP	0	P2 UP	0
P1 DOWN	0	P2 DOWN	0
P1 RIGHT	0	P2 RIGHT	0
P1 LEFT	0	P2 LEFT	0
P1 NOBU	0	P2 NOBU	0
P1 PUSH1	0	P2 PUSH1	0
P1 PUSH2	0	P2 PUSH2	0
COIN	0	PLAY2	0

Picture 3 "Joystick & Switch Test"

The screen will display all switches with a zero (0) to the right. The zero (0) should change to one (1) and increase by one each time Joystick is moved to the right. Moving Joystick to the left decreases each number by one. Inserting coin or pushing service switch increases coin number by one.

Press "PLAYER 1" button to change to picture 4.

3. MODE

DIP1	12345678
	00000000
DIP2	12345678
	00000000
TYPE	TABLE
HERO	3
1 COIN 1 PLAY	1 COIN 2 6 PLAY
BONUS 1	50000P
BONUS 2	100000 EVERY
LEVEL 1	

Picture 4 "Mode Check"

The screen will automatically display all programmable features with their respective settings. Settings should correspond to the position of the dip switches on the P.C. Board. The actual set mode is displayed at the bottom of the screen.

Press "PLAYER 1" button to change to picture 5.

4. FRONT
CHARA CODE 0000-0031
COLOR 00

FRONT CHARACTER

Picture 5 "Front Test"

Check monitor screen for character(s) display.

Press "PLAYER 1" button to change to picture 6.

5. MUSIC

MUSIC CODE = ?

MEDOLY 41-7B
EFFECT 81-BB
STOP OE

Picture 6 "Sound Test"

Set up Music Code to either 41-7B or 81-BB using Joystick. Push "FIRING" button to set. For no sound, set Music Code to OE and press "FIRING" button.

Press "PLAYER 1" button to complete test and exit diagnostics.

P.C. BOARD ASSEMBLY

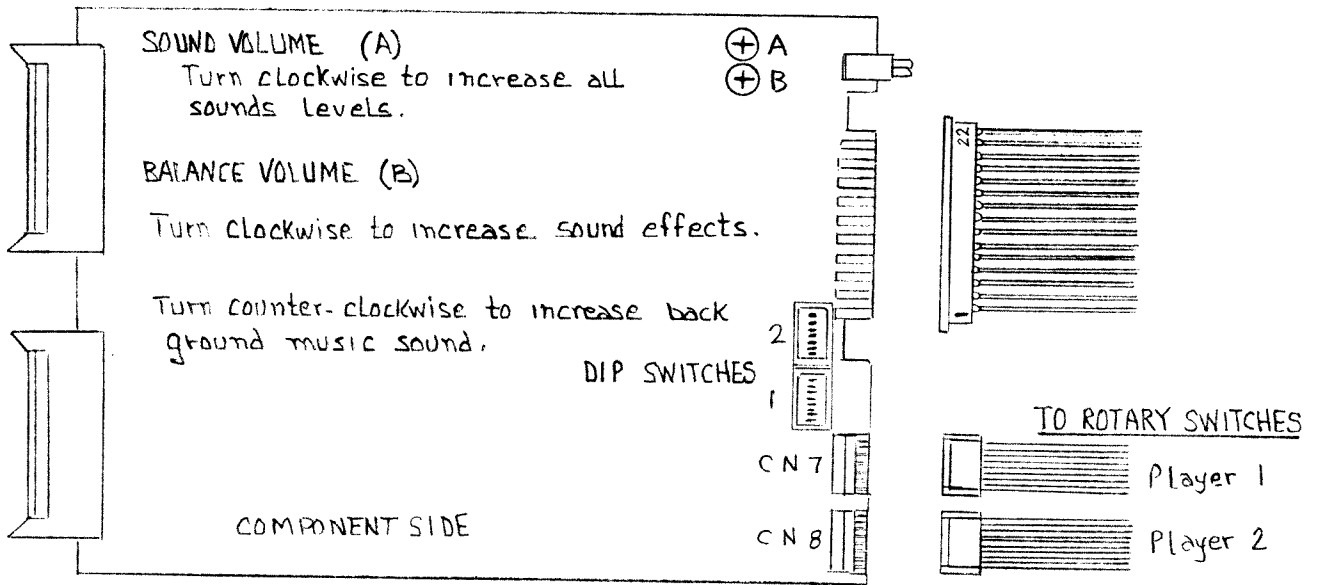

ROTARY SWITCH ASSEMBLY WIRING

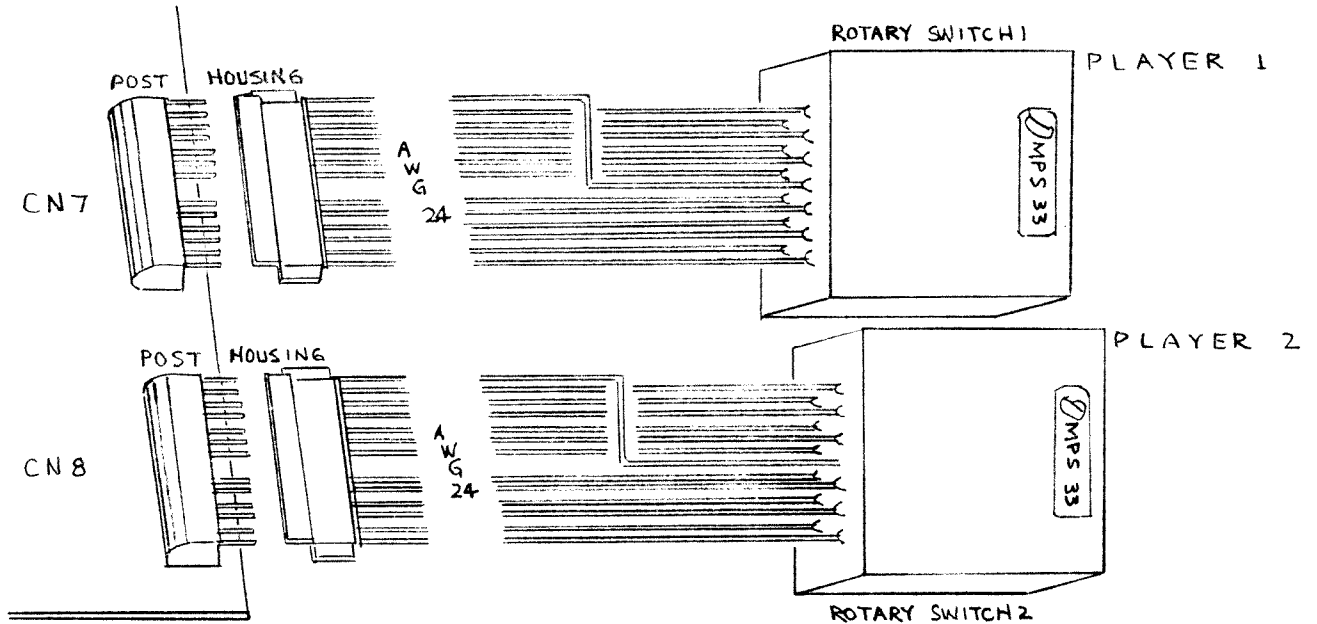

1. To avoid IC damage DO NOT use Multimeter to test Solid-State Modules.
2. Turn Main Power off when inserting or removing edge connectors from P.C. Board.
3. Shorting Reset Terminal (pin-6 of P.C. Board edge connector) to ground will reset CPU. If not used, leave open.

Figure-1

JOYSTICK ASSEMBLY

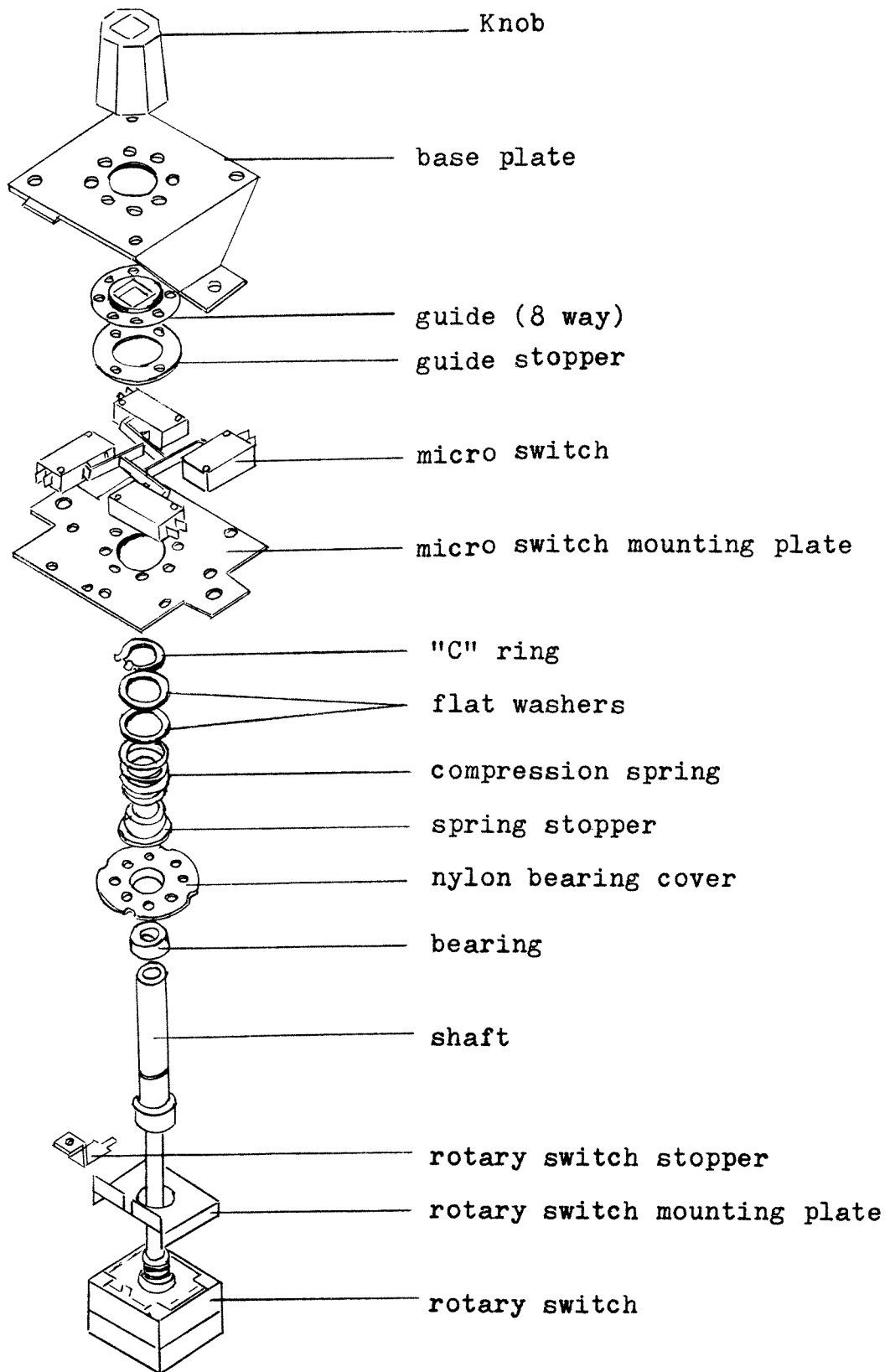

Figure-2

MONITOR

CONVERSION

VERT. TO HORZ.
&
HORZ. TO VERT.

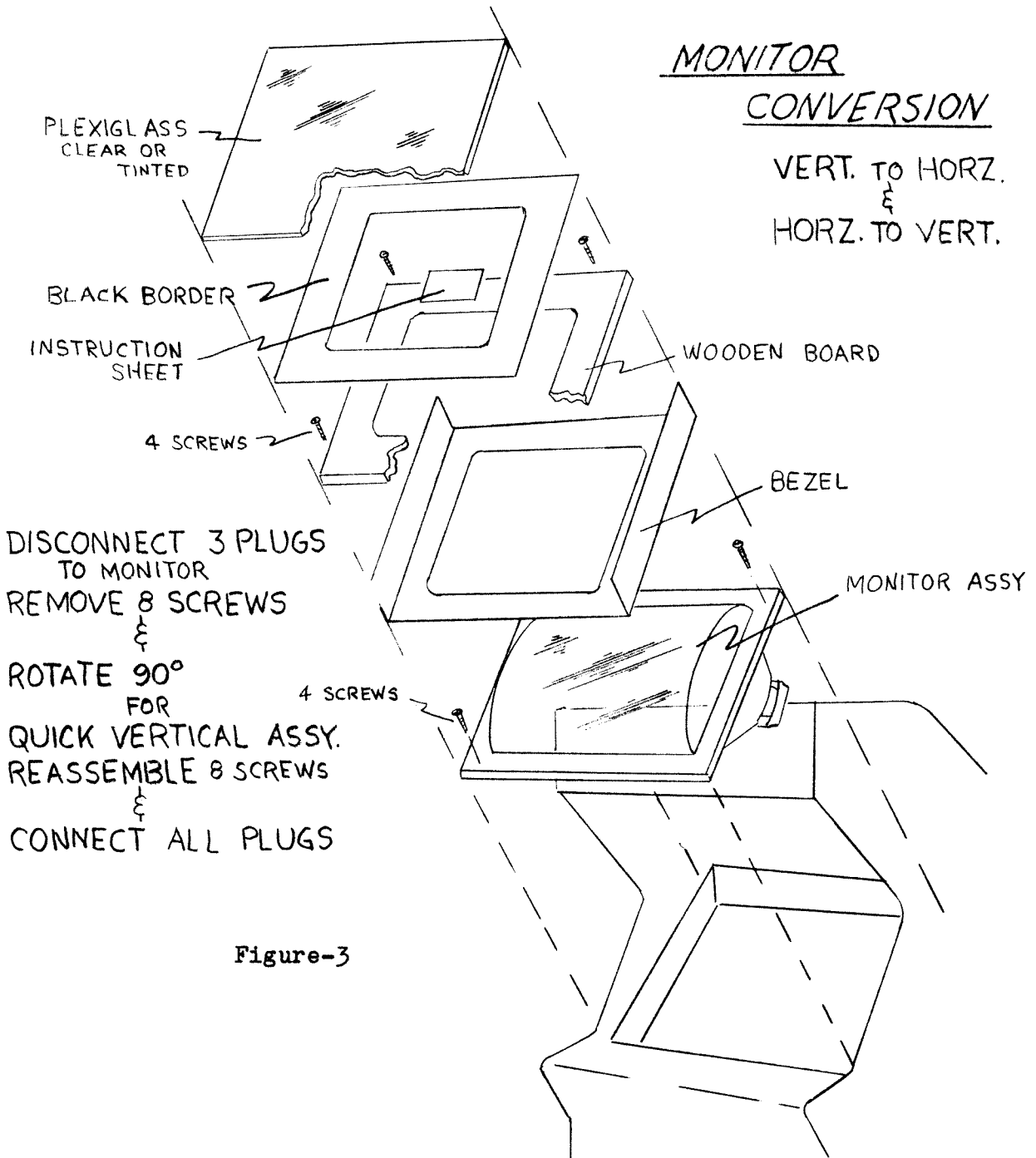
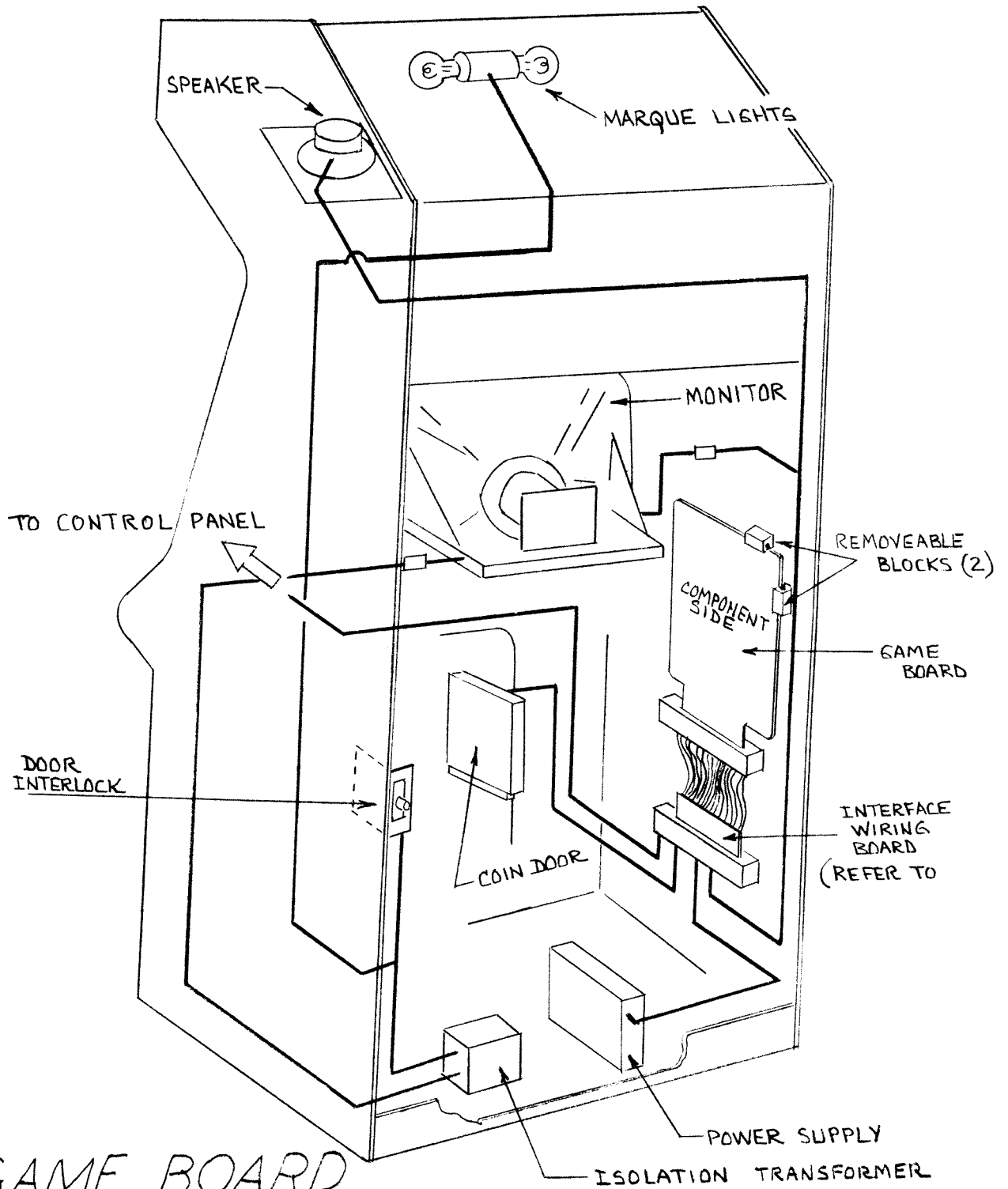

Figure-3

Figure-4



GAME BOARD
CONVERSION

WITH
HARNESS & COMPONENT LAYOUT

Figure-5

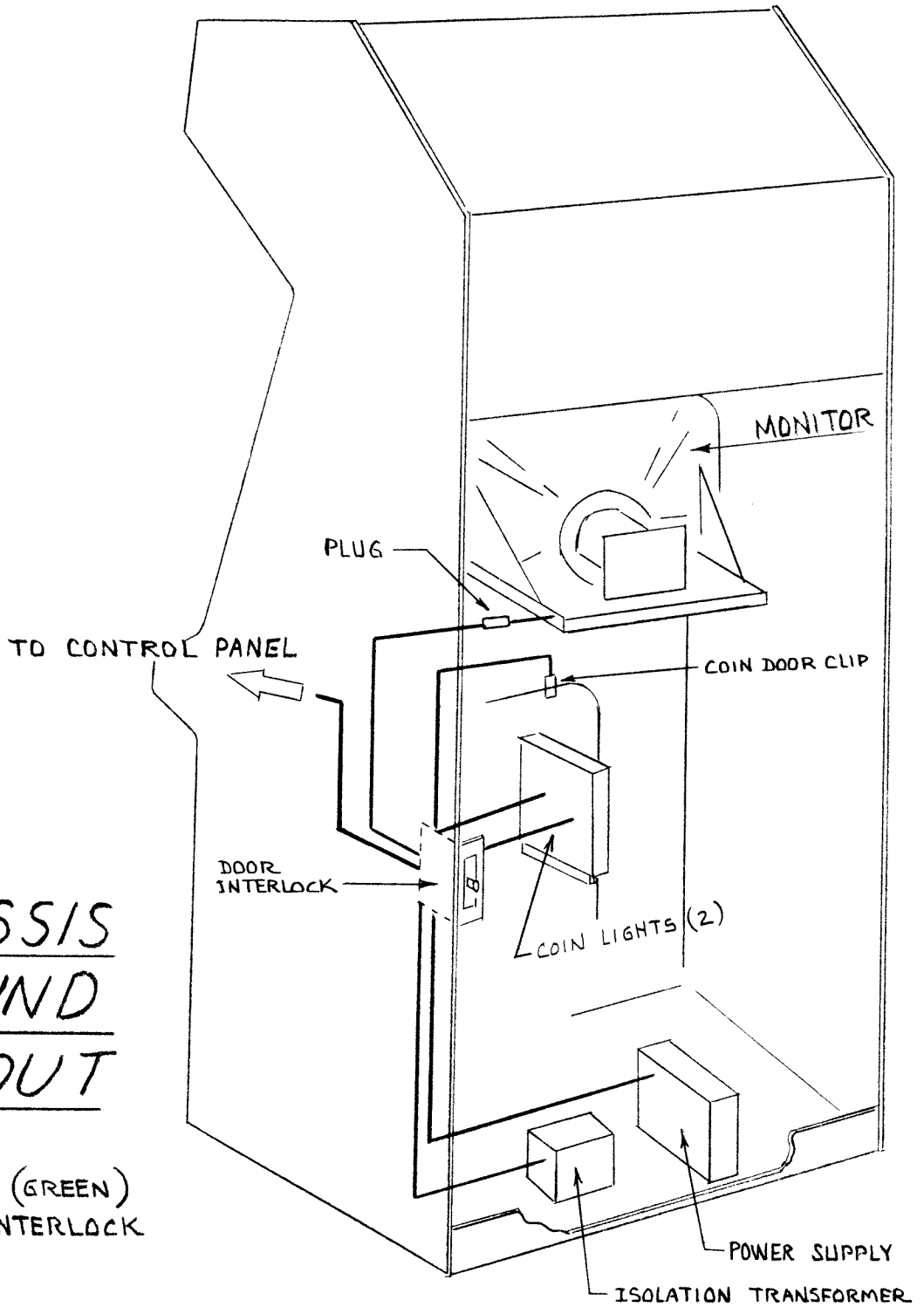

CHASSIS
GROUND
LAYOUT

(7) WIRES (GREEN)
FROM INTERLOCK

CONTROL PANEL GROUND HARNESS CONVERSION

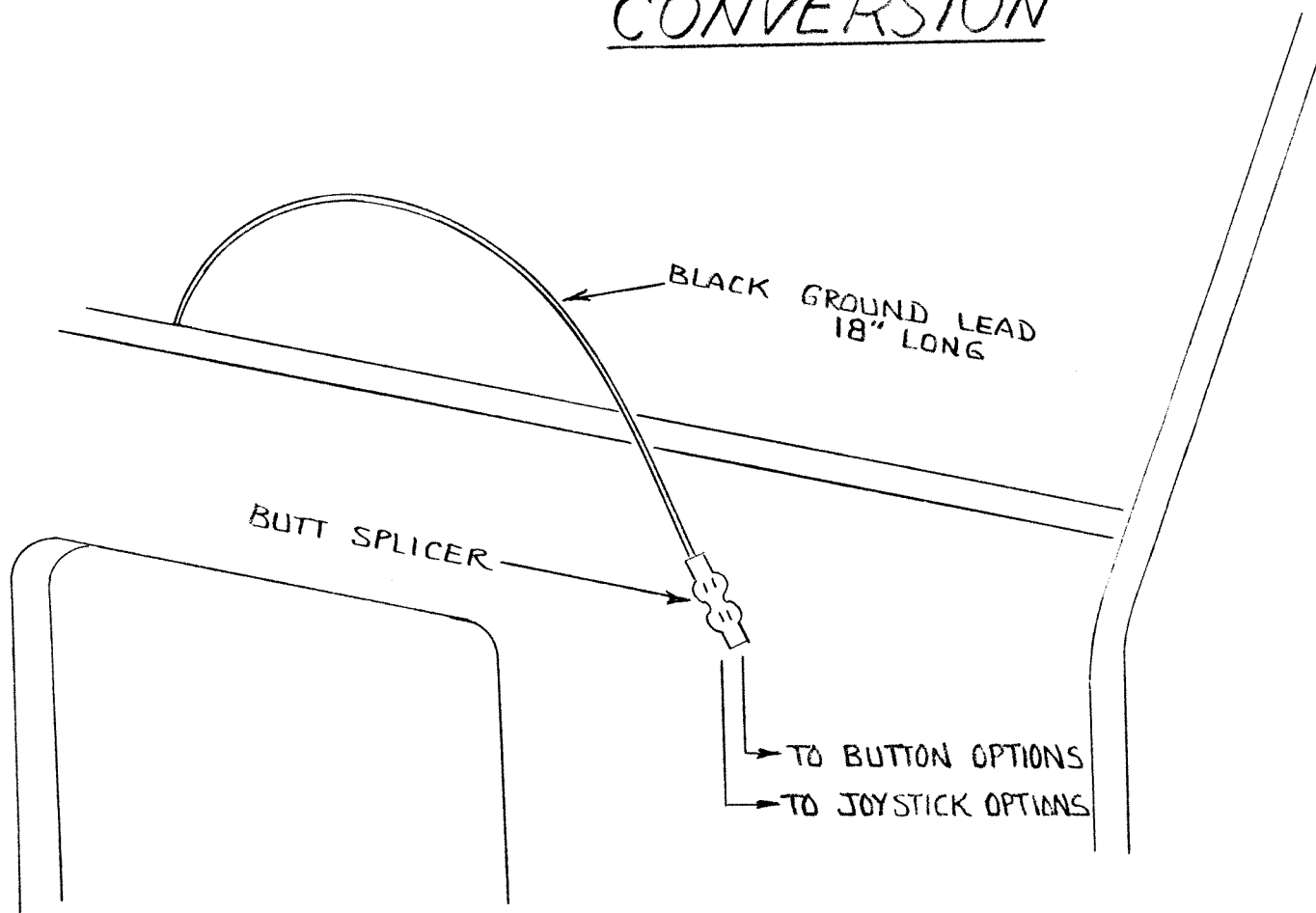
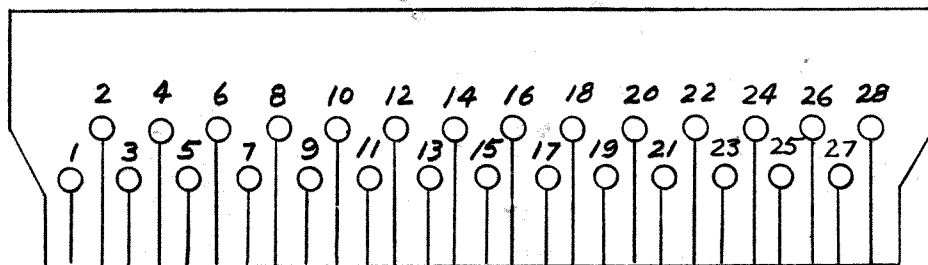

Figure-6

FOR BUTTON DUPLICATION
 (Such as right & left handed control buttons)

DO NOT cut, butt-splice or jumper any wire in the control panel as this will destroy the system for future use. In the event of button duplication, a jumper on the Interface Board to an unused control pad should be use. Remember that all grounds not supplied on the main Logic PCB must be added by jumpering from pins 1,2,A,B to the line needing ground. An example for coin switch application is shown below together with 1 & 2 player ground and control panel ground.



- SIDE 1 -

MATCH GAME BOARD FUNCTION WITH
 VIDEO HARDWARE SYSTEM & SOLDER

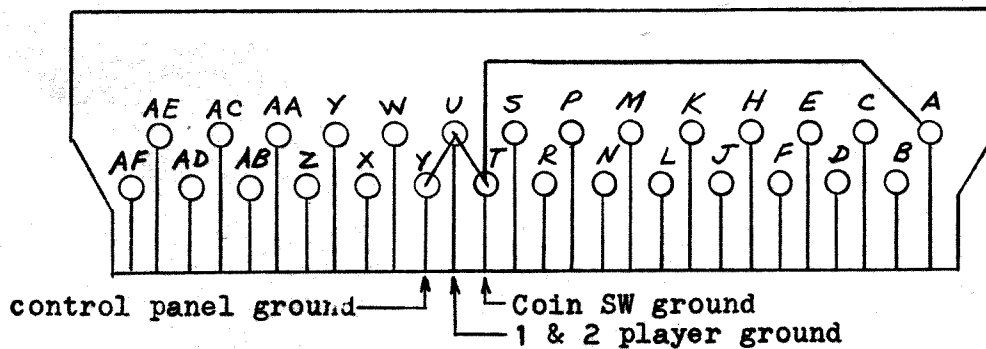

- SIDE A -

INTERFACE WIRING
BOARD

Figure-7

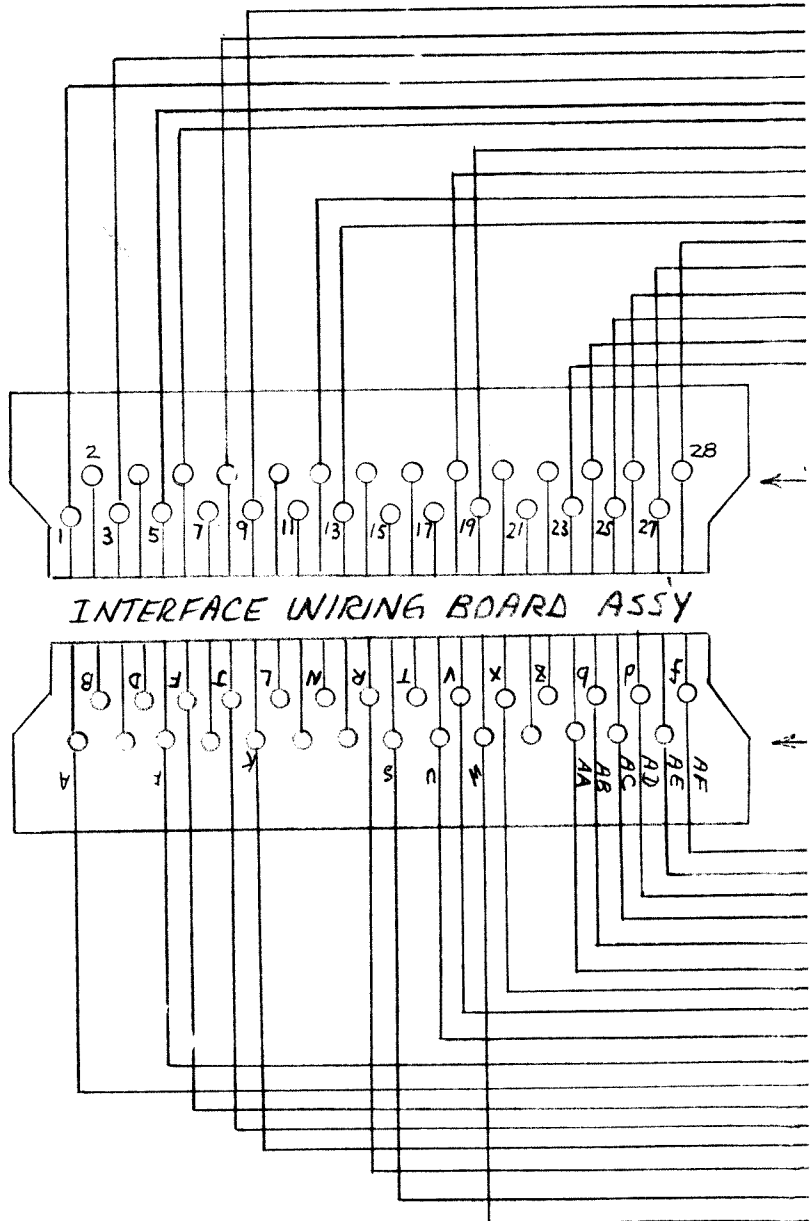

INTERFACE WIRING BOARD ASSY

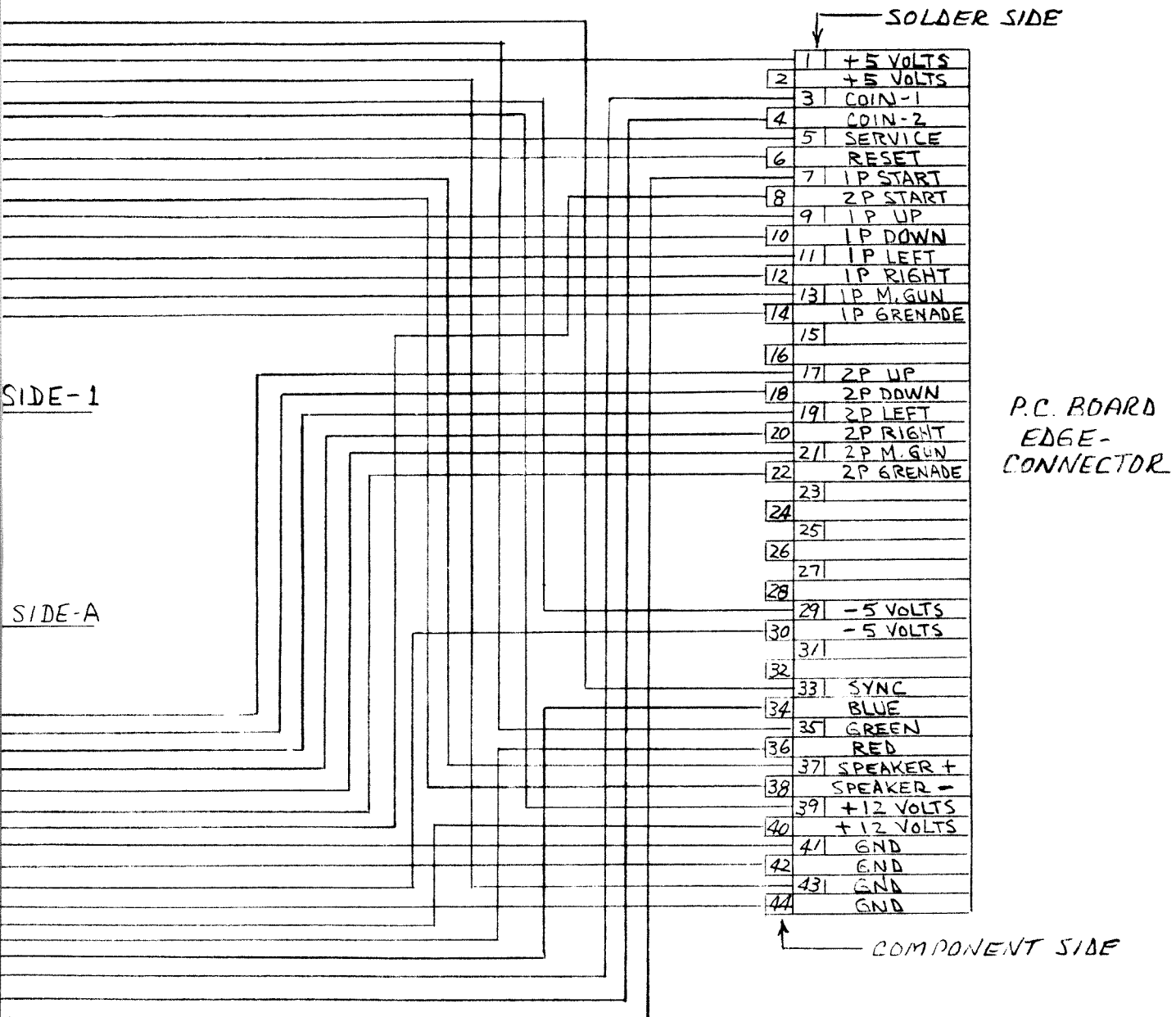

SOLDER SIDE

P.C. BOARD
EDGE-
CONNECTOR

COMPONENT SIDE

DYNAMO CORP.		2525 HANDLEY-EDERVILLE RD. RICHLAND HILLS, TX 76118	
SCALE:	APPROVED BY:	DRAWN BY:	M. JASSO
DATE: 3-25-86		REVISED:	
NAME: INTERFACE BOARD / EDGE CONNECTOR ASSEMBLY			
"IKARI WARRIORS"			DRAWING NUMBER

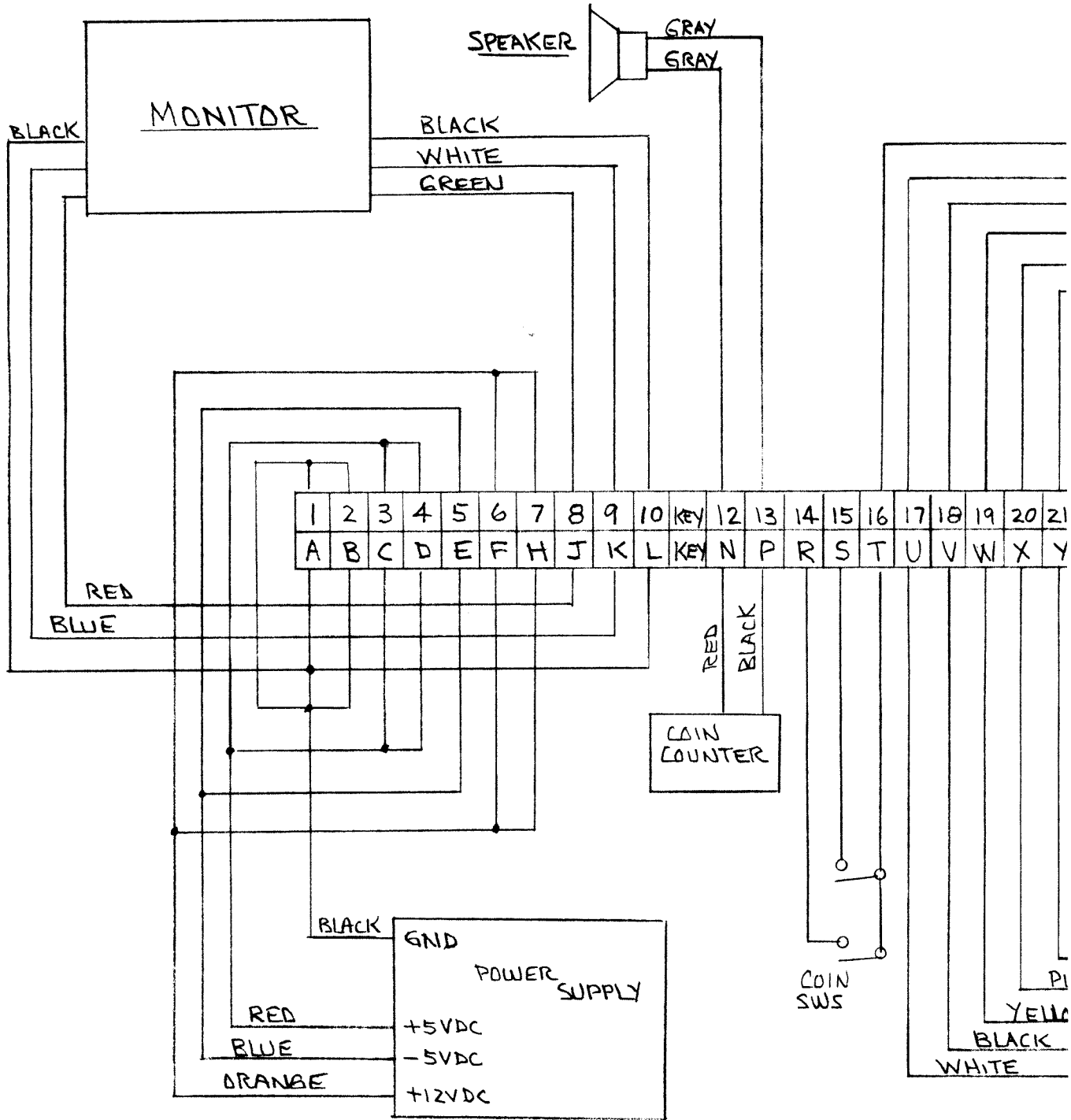

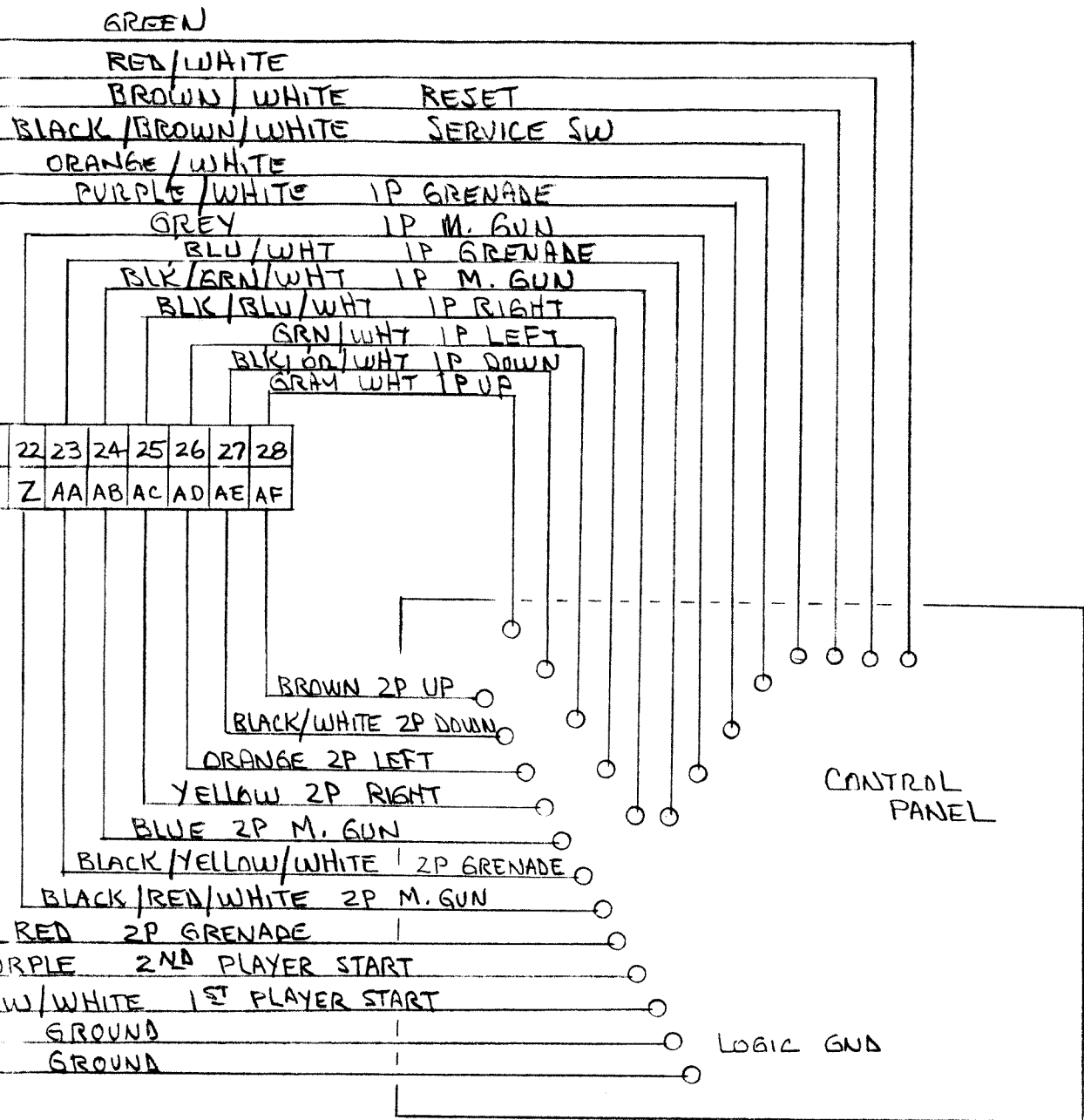

DYNAMO CORP.

2525 HANDLEY-EDERVILLE RD. RICHLANDS HILLS, TX 76118

SCALE:

APPROVED BY:

DRAWN BY

M. JASSO

DATE:

3-25-86

REVISED

UNIVERSAL VIDEO HARDWARE SYSTEM

DRAWING NUMBER